



**REQUEST FOR PROPOSALS  
#600-33-19**

**AUTHORITY WIDE SITE IMPROVEMENTS**

**Due  
August 26, 2019  
2:00 P.M.**

**To: Mr. Kim Detrick  
Director of Procurement/Chief Contracting Officer  
100 Ross Street, 2<sup>nd</sup> Floor - Suite 200  
Pittsburgh, PA 15219**

## HOUSING AUTHORITY OF THE CITY OF PITTSBURGH

### Request for Proposals for Authority Wide Site Improvements

#### TABLE OF CONTENTS

I.	Introduction.....	1
II.	Scope of Services.....	3
III.	General Requirements & Definitions.....	4
IV.	Content of Response Documents.....	5
V.	Evaluation Criteria.....	11
VI.	Procurement and Award Process.....	12

#### Attachments:

- A.** Form of Agreement
- B.** Form of Bid (including exhibits C, D, E and F)
- C.** Performance and Payment Bonds
- D.** General Conditions for Construction Contracts (*HUD 5370*) and Supplemental General Conditions
- E.** Instructions to Bidders for Contracts (*HUD 5369*)
- F.** Representations, Certifications, and Other Statements of Bidders (*HUD 5369A*)
- G.** MBE/WBE Special Participation Summary
- H.** Sample MBE/WBE Letter of Intent
- I.** Section 3 Clause/Opportunities Plan and Related Data
- J.** Firm Demographics Form
- K.** Request for Taxpayer Identification Number and Certification (*IRS W-9*)
- L.** Davis-Bacon Wage Determinations
- M.** Specifications
- N.** Special Provisions – Documents Required for Payment
- O.** Non-Collusion Affidavit

## SECTION I INTRODUCTION

The Housing Authority of the City of Pittsburgh (“HACP”) hereby requests proposals from qualified contractors (hereinafter, “vendor”) to perform authority wide site improvements (hereinafter, “services”). A more detailed scope of services is provided in Section II of this Request for Proposals (“RFP”).

HACP owns and directly manages over 4,000 public housing units in the City of Pittsburgh consisting of family and elderly housing units within approximately 20 communities and amongst various scattered site locations. The selected professionals may be requested to provide services at any HACP community or scattered site.

The United States Department of Housing and Urban Development Department (“HUD”) provides the funding for the services and therefore all services performed must be in compliance with all rules and regulations of this program, and all other applicable Federal regulations including, but not limited to, Handicap Accessibility (Section 504), Americans with Disabilities Act (ADA), Uniform Federal Accessibility Standards (UFAS), Davis-Bacon wage requirements, Environmental Protection Agency rules and regulations, HUD’s Modernization Design Standards and Federal procurement requirements.

In addition to the Federal laws, rules and regulations, all work must also be performed in compliance with all Commonwealth of Pennsylvania laws and regulations and the Allegheny County and the City of Pittsburgh’s requirements.

HACP seeks proposals from firms qualified to provide services and is contemplating the award of a contract or multiple contracts through this solicitation process for a period of three (3) years with two (2) one (1) year extension options whereby HACP will authorize the selected vendor(s), during a stated time period and for the services HACP requires, to perform the services on an as-needed basis through the use of Task Orders. **Attachment A** – Form of Agreement is the contract that will be used through this solicitation process.

Any questions regarding this Request for Proposals should be in writing and directed to:

ATTN: Mr. Kim Detrick  
Director of Procurement/Chief Contracting Officer  
100 Ross Street, 2<sup>nd</sup> Floor – Suite 200  
Pittsburgh, PA 15219  
Fax No.: 412-456-5007  
Email: [Kim.Detrick@hacp.org](mailto:Kim.Detrick@hacp.org)

A complete proposal package may be obtained from:

Business Opportunities Section of the HACP website, [www.hacp.org](http://www.hacp.org)

Following are the Key Dates associated with this Request for Proposals:  
(subject to change at HACP's discretion through Addenda to solicitation issued as applicable)

Pre-Submission Conference: **August 14, 2019 at 10:00 A.M.**  
Development and Modernization Department  
100 Ross Street, 2<sup>nd</sup> Floor – Suite 200  
Pittsburgh, PA 15219

Final Submission of Written Questions: **August 19, 2019 at 10:00 A.M.**  
Mr. Kim Detrick, Director of Procurement/Chief Contracting Officer  
Housing Authority City of Pittsburgh, Procurement Department  
100 Ross Street, 2<sup>nd</sup> Floor – Suite 200  
Pittsburgh, PA 15219  
Fax No.: 412-456-5007  
Email: [Kim.Detrick@hacp.org](mailto:Kim.Detrick@hacp.org)

Proposals Due: **August 26, 2019 at 2:00 P.M.**  
Mr. Kim Detrick, Director of Procurement/Chief Contracting Officer  
Housing Authority City of Pittsburgh, Procurement Department  
100 Ross Street, 2<sup>nd</sup> Floor – Suite 200  
Pittsburgh, PA 15219

## SECTION II SCOPE OF SERVICES

The selected vendor(s) will provide an indefinite quantity of authority wide site improvements (hereinafter, “work”) on an as needed basis through the use of Task Orders. A minimum of one Task Order will be issued to each selected vendor. The contract(s) is expected to have an overall duration of up to three (3) years with two (2) one (1) year extension options.

Once an indefinite quantity task order contract has been established between the parties and when the HACP identifies a need, the HACP will prepare a scope of work, independent cost estimate of the work and request a Task Order proposal from the vendor. Prior to a vendor submitting its proposal, the vendor shall conduct a site investigation to ascertain the conditions affecting the work. The vendor will submit a Task Order proposal usually within 2-10 calendars as prescribed by the HACP depending on the complexity of the scope of work. The proposal will be based on the unit process and rates as set forth in the Vendor’s Form of Bid attached hereto as **Attachment B**. HACP reviews and negotiates the Task Order proposal with the vendor, at which time the Contracting Officer issues a written Task Order Notice to Proceed. The vendor(s) shall perform the work negotiated under each Task Order.

**The Authority Wide Site Improvements shall include scope of work items set forth in the Specifications (see Attachment M).**

Any and all services performed must be in compliance with all applicable Federal regulations including, but not limited to, Handicap Accessibility (Section 504), Americans with Disabilities Act (ADA), Uniform Federal Accessibility Standards (UFAS), Environmental requirements, and Federal procurement requirements. In addition, all services must be performed in compliance with applicable Commonwealth of Pennsylvania laws and regulations and City of Pittsburgh building code requirements and ordinances.

The vendor(s) shall furnish all labor, material, tools, equipment, transportation and skills necessary to perform all services in the most expeditious and economical manner consistent with interest of HACP and HUD. All work must be performed according to HACP specifications hereto included as **Attachment M**.

The work performed through this solicitation is subject to the requirements of **Clause 47 Labor Standards - Davis-Bacon and related Acts**. The wage determination(s) (**Attachment L**) of the Secretary of Labor are included with the solicitation and will be utilized and enforced as applicable to the scope of work for each Task Order.

Dependent on the nature of the scope of a Task Order, Performance and Payment Bonds may be required (**Attachment C**), and as such, as part of the request for task order proposal process, will be requested as necessary.

HACP is contemplating the award of multiple contracts through this solicitation process. Each Offeror must review the Form of Agreement included as **Attachment A**, the General Conditions for Construction Contracts (HUD 5370) and Supplemental General Conditions included at **Attachment D**. Each Offeror must sign the Form of Agreement contract and return it to HACP as a part of its proposal. By signing a Form of Agreement contract, if the HACP accepts and signs the Agreement, the Agreement shall be binding on both parties.

**SECTION III  
GENERAL REQUIREMENTS & DEFINITIONS**

**A. General Requirements**

An Offeror may be an individual or a business corporation, partnership or a joint venture duly authorized to do business in the City of Pittsburgh, financially sound and able to provide the services being procured by HACP.

If an Offeror has been debarred, suspended or otherwise lawfully precluded from participating in any public procurement activity, such firm shall disclose that information in its offer, which may be sufficient grounds for disqualification. If the selected firm fails to disclose such information, and HACP discovers it thereafter, then HACP may terminate the contract.

Each Offeror must be in good standing with HACP, and any Federal, State or Municipality that has or has had a contracting relationship with the firm. Therefore, if a Federal, State or Municipal entity has terminated any contract with an Offeror for deficiencies or defaults, that Offeror is not eligible to submit a Response to this Solicitation.

The Offeror must also be fully licensed and in good standing to perform professional services in the Commonwealth of Pennsylvania and in the City of Pittsburgh.

**B. Definitions**

“Good Standing” means the Offeror has performed to HACP’s satisfaction on any HACP project and is not suspended, debarred or otherwise lawfully excluded from doing business with any Federal, State or Municipal entity.

## **SECTION IV CONTENT OF RESPONSE DOCUMENTS**

Offerors submitting Proposals should fully read and comprehend the General Conditions for Construction Contracts (HUD 5370) and Supplemental General Conditions provided in **Attachment D** and Instructions to Bidders for Contracts (HUD 5369) provided in **Attachment E**. Proposals received without all of the required information may be deemed non-responsive and rejected. Offerors must submit one original plus three (3) hard copies and one (1) electronic copy of their proposal. Proposals must include, in the same order as below and using the forms attached hereto, the following information, exhibits and schedules:

### **A. General Information**

1. Letter of Interest (Cover letter) including contact name and telephone number.
2. Type of Organization: Corporation, Partnership, Joint Venture or Sole Proprietorship. Names of shareholders, partners, principals and any other persons exercising control over the Firm.
3. Description of the Offeror's Capacity:
  - (a) Staff resources, office facilities, equipment, etc.
  - (b) Listing of ALL current or completed HACP related project(s), the Initial Contract Value, Change Orders, if any, and Final Contract Value. If the project was not completed within budget, please explain the circumstances or justification for the change order(s).
  - (c) Listing of ALL current work and their dollar value(s).
4. Organizational Certifications:
  - (a) Copies of Certificate of Incorporation, Partnership Agreement, Joint Venture or other organizational document.
  - (b) Applicable Licenses/Certifications.
  - (c) A corporate resolution signed by the Secretary of the Corporation and notarized, certifying the name of the individual(s) authorized to sign the offer, the contract and any amendments thereto.

### **B. Firm's Previous Related Experience & Capacity**

Describe why Offeror feels its organization is qualified to provide the services requested in this RFP. Describe the types of activities and/or previous undertakings that qualify the Offeror for selection. Include a list of developments or projects in which the Offeror has performed services similar to those described in this RFP. Such listing shall include at least the following information:

1. Name of the contracting entity.
2. Name, title and a telephone number of a contact person for each identified contracting entity to permit reference checks to be performed. The identified party must be one who has firsthand knowledge regarding the operation of the contracted facility or project and who was involved in managing the contract between the Offeror and the contracting entity.

3. Original and final cost of each project and the amount of any change orders on each project or contract (if multiple primes were involved on each project).

**C. Offeror's Capacity**

Provide information demonstrating ability of the Offeror to provide the resources (staffing, equipment, office facilities and other) necessary for the timely and efficient implementation of HACP's goals and objectives as described in this solicitation. Due to the nature of this procurement, capacity will also be evaluated based on the Offeror's ability to be available to provide the resources in an "on-call" and/or "as-requested" manner.

**D. Proposed Staffing and Sub-consultants' Responsibilities and Qualifications**

Provide the following information relative to the proposed staffing and sub-consultants that will provide services under the contract resulting from this RFP:

1. Provide background information regarding each identified Staff member that accurately describes his or her employment history and relevant experience providing services similar to those described in this Request for Proposals.
2. Description of the Scope of Services for at least three (3) projects on which the Staff and/or sub-consultant have provided services similar to those described in this Request for Proposals. Please include the individual's role in each project and all relevant aspects of each project such as: type of facility, construction contract value, and type of construction activity.
3. Description of the intended management of the proposed staff in order to ensure that the services are being provided in an efficient manner.

**E. Representations, Certifications, and Other Statements of Bidders**

Each Offeror must complete the Representations, Certifications, and Other Statements of Bidders (HUD 5369A) provided in **Attachment F**.

**F. Minority and Women Business Participation**

Provide a written plan that describes ways the Offeror will utilize MBE/WBE businesses to comply with HACP and City of Pittsburgh's established thresholds of 18% Minority-owned Business Enterprise and 7% Woman-owned Business Enterprise participation. Also, complete the table provided in **Attachment G** and include with your proposal. Proposals must demonstrate how the Offeror intends to meet or exceed these goals.

*HACP MBE and WBE Goals. It is the policy of HACP to ensure that Minority Business Enterprises (MBEs) and Women-owned Businesses (WBEs) are provided maximum opportunity to participate in contracts let by HACP. In accordance with Executive Order 11625, HACP has established a minimum threshold of eighteen percent (18%) of the total dollar amount for MBE utilization in this contract. HACP has established a*



*seven percent (7%) minimum threshold for participation of WBEs, and, HACP strongly encourages and affirmatively promotes the use of MBEs and WBEs in all HACP contracts. For these purposes, an MBE is defined as "any legal entity other than a joint venture, organized to engage in commercial transactions, that is at least fifty-one percent (51%) owned and controlled by one or more minority persons." Also, a minority person is defined as a member of a socially or economically disadvantaged minority group, which includes African-Americans, Hispanic-Americans, Native-Americans, and Asian-Americans. A WBE/MBE is defined as "any legal entity other than a joint venture, organized to engage in commercial transactions, that is at least fifty-one percent (51%) owned and controlled by a female.*

**Proposals submitted in response to this solicitation MUST include an MBE/WBE participation plan which, at a minimum, demonstrates "Best Efforts" have been taken to achieve compliance with MBE/WBE goals. HACP's Procurement Policy defines "Best Efforts" in compliance with MBE/WBE goals to mean that the Offeror must certify and document with its bid or proposal that it has contacted in writing at least ten (10) certified MBE/WBE subcontractors to participate in the proposed contract with HACP or lesser number if the Offeror provides documentation that ten (10) certified MBE and ten (10) certified WBE subcontractors could not be identified. Each Offeror shall certify as to the same under penalty of perjury and shall submit the back-up documentation with its bid or proposal. Any bid or proposal received that does not contain such certification and back-up documentation acceptable to HACP may be deemed non-responsive by HACP.**

If you have any questions regarding the HACP MBE/WBE policy contact Mr. Kim Detrick, Director of Procurement/Chief Contracting Officer by e-mail at [Kim.Detrick@hacp.org](mailto:Kim.Detrick@hacp.org) or by contacting him at the Procurement Department, Housing Authority of the City of Pittsburgh, 100 Ross Street, Suite 200, Pittsburgh, PA 15219, telephone (412) 456-5116, Option 1.

### **G. Section 3 Participation**

Provide a written plan that describes ways the Offeror will fulfill Section 3 Participation to comply with HUD and HACP's Section 3 requirements. Also, refer to the Section 3 Clause and complete the forms provided in **Attachment I** and include with your proposal. Proposals must demonstrate how the Offeror intends to meet or exceed these goals.

Section 3 of the Housing and Urban Development Act of 1968, as amended (12 U.S.C. 1701, et seq.) (the "Act") requires the Housing Authority of the City of Pittsburgh to ensure that employment and other economic and business opportunities generated by financial assistance from the Department of Housing and Urban Development ("HUD"), to the greatest extent feasible, are directed to public housing residents and other low income persons, particularly recipients of government housing assistance, and business concerns that provide economic opportunities to low and very low income persons.

To comply with the Act HACP requires its vendors to provide equal employment

opportunity to all employees and applicants for employment without regard to race, color, religion, sex, national origin, disability, veteran's or marital status, or economic status and to take affirmative action to ensure that both job applicants and existing employees are given fair and equal treatment.

The goal of this policy is to obtain a reasonable level of success in the recruitment, employment, and utilization of HACP residents and other eligible persons and/or businesses by the vendors working on contracts partially or wholly funded with HUD monies. HACP shall examine and consider an Offeror's potential for success in providing employment and business opportunities to those covered under Section 3 prior to acting on any proposed contract award. In response to any procurement (RFP, RFQ or IFB) HACP will require submission of the Section 3 Opportunities Plan and roster of current employees, and certification that the Offeror will comply with the requirements of Section 3.

HACP, in accordance with applicable laws and regulations, has established employment and training goals that Offerors and subcontractors are expected to meet in order to comply with Section 3 requirements. The goal is that thirty percent (30%) of the aggregate number of new hires in any fiscal year shall be Section 3 eligible. It is the vendor's responsibility to implement progressive efforts to attain Section 3 compliance. HACP, in accordance with applicable laws and regulations, has established a hiring and/or training requirement for vendors. This requirement establishes a sliding scale threshold based upon contract size for the value of Section 3 hiring and/or training to be achieved by the vendor. In the event that the threshold level cannot be achieved through hiring by the vendor and/or subcontractors, the vendor may either a) incur the cost of employment and related skill training provided to residents in amounts commensurate with the sliding scale amount, or b) make a cash contribution to the HACP's non-profit Education Fund in an amount commensurate with the sliding scale amount.

HACP will provide assistance to vendors and Offerors in identifying qualified and eligible Section 3 residents and businesses, and has established procedures for monitoring vendor compliance.

The Section 3 Program Manual, as may be revised from time to time, contains information on this policy, and the requirements, procedures, forms, and assistance opportunities that have been established to implement this policy.

Below are HACP Section 3 Guidelines as listed in the Program Manual:

<b>RESIDENT HIRING SCALE</b>	
<b>TOTAL LABOR DOLLARS USE TOTAL CONTRACT AMOUNT FOR SERVICE CONTRACTS</b>	<b>RESIDENT LABOR AS A % OF TOTAL LABOR DOLLARS</b>
Labor dollars \$25,000 but less than \$100,000	10% of the labor dollars
\$100,000, but less than \$200,000	9% of the labor dollars
At least \$200,000, but less than \$300,000	8% of the labor dollars

At least \$300,000, but less than \$400,000	7% of the labor dollars
At least \$400,000, but less than \$500,000	6% of the labor dollars
At least \$500,000, but less than \$1 million	5% of the labor dollars
At least \$1 million, but less than \$2 million	4% of the labor dollars
At least \$2 million, but less than \$4 million	3% of the labor dollars
At least \$4 million, but less than \$7 million	2% of the labor dollars
\$7 million or more	½ to 1 % of the labor dollars

A copy of HACP's Section 3 Program Manual is available for download at <http://www.hacp.org/business-opportunities/section-3-business-concerns-faq>

**Any bid or proposal received that does not contain such Section 3 Opportunities Plan and related data acceptable to HACP may be deemed non-responsive by HACP.**

If you have any questions regarding the Section 3 Requirements or would like to discuss goals and planning for Section 3 Requirements contact Mr. Lloyd Wilson, III, Section 3 Coordinator by e-mail at [Lloyd.Wilson@hacp.org](mailto:Lloyd.Wilson@hacp.org) or by contacting him at Housing Authority of the City of Pittsburgh, Bedford Hope Center 2305 Bedford Avenue, Pittsburgh, PA 15219, telephone (412) 456-5000, extension 1048.

**H. Fee Proposal**

In a separate, sealed envelope, provide the Form of Bid, in the format of **Attachment I**, to complete the work described in the RFP and the Offeror's Proposal. The Form of Bid should separately identify the hourly rates for staff and Sub-Contractor as applicable. It is noted that the proposed hourly rates will be evaluated as discussed in section VI.

Proposed hourly rates should include all overhead and appropriate expenses. Profit shall be indicated separately.

Escalation, if applicable, should be reflected as a percentage of the base year's fully burdened rates and shown as percentage change that would apply in the fourth and fifth years only. Escalation and profit shall be indicated on the attached Form of Bid. **Please complete a separate form for any/all sub-consultants.**

**I. Firm Demographics**

Provide demographic description of all employees of your firm using the table provided in **Attachment J**.

**J. Instructions to Bidders for Contracts**

Offerors submitting Proposals should fully read and comprehend the Instructions to Bidders for Contracts attached hereto as **Attachment E**.

**K. Execution Form of Agreement Contract**

Each Offeror must review the Form of Agreement contract included as **Attachment A** and the General Conditions for Construction Contracts (HUD 5370) and Supplemental General Conditions included as **Attachment D**. Each Offeror must sign the Agreement and return it to the Housing Authority as a part of each proposal. By signing this Form of Agreement, if the Authority accepts and signs the Agreement, the Agreement shall be binding on both parties.

**L. TIN/W-9 Form**

Complete a W-9 Request for Tax Payer Identification Number and Certification, as provided in **Attachment K**.

**M. MBE/WBE Letter of Intent**

Complete a Letter of Intent for each MBE/WBE firm contacted. A sample letter is provided in **Attachment H**.

**N. Special Provisions**

Sign and date the Special Provisions – Documents Required for Payment, as provided in **Attachment N**.

**O. Non-Collusion Affidavit**

Complete the Non-Collusion Affidavit, as provided in **Attachment O**.

## SECTION V EVALUATION CRITERIA

The Evaluation Committee will evaluate and will score each proposal that is submitted as a complete response. It is noted that the proposed Fee will be evaluated separately. Responses may receive a maximum score of one hundred (100) points subdivided as follows:

**Experience of Proposed Staff:** **Maximum 20 points**

Demonstrated successful experience and capability of the proposed staff and sub-consultant(s) proposed for this project in providing services described in this Request for Proposals. Demonstrated experience and familiarity in working within a federal and state regulated environment.

**Experience of Firm:** **Maximum 15 points**

Demonstrated successful experience and capability of the Offeror in providing services described in this Request for Proposals. Demonstrated experience and familiarity in working within a federal and state regulated environment.

**Cost Proposal:** **Maximum 25 points**

Proposed unit prices and labor rates set forth in the Form of Bid are reasonable and appropriate in relation to the work requested.

**Capacity:** **Maximum 20 points**

Demonstrated ability of the Offeror to provide the resources (labor, material, tools, equipment, transportation, and other) necessary for the timely and efficient implementation of HACP's goals and objectives as described in this solicitation. Due to the nature of this procurement, capacity will also be based on the Offeror's ability to be available to provide the resources in an "on-call" and/or "as-requested" manner.

**MBE/WBE Participation:** **Maximum 10 points**

Demonstrated experience and/or commitment of the Offeror to assist HACP in meeting its requirement and goals related to Minority/Women Business subcontracting and employment opportunities.

**Section 3 Participation:** **Maximum 10 points**

Demonstrated experience and/or commitment of the Offeror to assist HACP in meeting its requirements and goals related to Section 3 Program.

**Deductions**

Points may be deducted for failure to submit all required documents or for submitting irrelevant or redundant material.

## **SECTION VI PROCUREMENT AND AWARD PROCESS**

Pursuant to 2 C.F.R. 200.319, the services are being procured for the services described in Section II (Scope of Services) of this solicitation. The following instructions are intended to aid Offerors in the preparation of their Proposals:

### **A. Pre-Submission Conference**

A pre-submission conference will be conducted on **August 14, 2019 at 10:00 A.M., at the Development & Modernization Department, 100 Ross Street, Suite 200, Pittsburgh, PA 15219**. Nothing discussed or expressed at the Pre-Submission Conference will change, alter, amend or otherwise modify the terms of this Solicitation unless a subsequent written amendment (addendum) is issued. Verbal responses by HACP's representatives shall not constitute an amendment or change to this Solicitation.

Material issues raised and addressed at the Pre-Submission Conference shall be answered solely through an addendum to this Solicitation. Likewise, ambiguities and defects of this Solicitation raised at the Pre-Submission Conference shall be corrected by a written amendment only, which, if issued, shall form an integral part hereof.

All prospective respondents are strongly encouraged to attend the Pre-Submission Conference. Failure to attend will not excuse the legal contractual duty imposed by this Solicitation and the subsequent contract on each respondent to familiarize itself with the request for proposals.

### **B. Amendments to Solicitation**

Any and all amendments to this Solicitation shall be sent by certified mail/return receipt requested, electronic mail, and/or by fax, to all potential Offerors who attend the Pre-Submission Conference and/or receive the solicitation materials.

*Notwithstanding any information that may be contained in the Solicitation and amendments thereto, Offerors are responsible for obtaining all information required, thus enabling them to submit Responses.*

### **C. Submission of Proposals and/or Amendments to Proposals; Deadlines**

Proposals may be hand-delivered or sent by certified or registered mail/return receipt requested, to the following:

Mr. Kim Detrick, Director of Procurement/Chief Contracting Officer  
Housing Authority City of Pittsburgh, Procurement Department  
100 Ross Street, 2<sup>nd</sup> Floor – Suite 200  
Pittsburgh, PA 15219

Proposals must be received at the above address no later than **August 26, 2019 at 2:00 P.M.**, regardless of the selected delivery mechanism.

Proposals will be date-time stamped immediately upon receipt at HACP to document their timeliness. Any Proposal received after the specified deadline shall be automatically rejected and will be returned unopened except as identified in the Instructions to Offerors attached hereto.

Any amendments to a Proposal must be received before the specified Proposal due date and time established for the delivery of the original Proposal except as identified in the Instructions to Offerors attached hereto.

#### **D. Evaluation and Award Process**

HACP staff will review each Proposal to determine if it is complete and if it is responsive to this Request for Proposals. HACP may allow Offerors to correct minor deficiencies in their Proposals that do not materially affect their Proposal.

All Proposals determined to be complete and responsive will be provided to an HACP Evaluation Committee. HACP's Evaluation Committee will evaluate the Proposals utilizing the criteria established in Section V of this Request for Proposals. **Only firms whose proposals are determined to be responsive and responsible and in the best interest of the HACP will be considered for contract award.**

HACP reserves the right to interview selected Offerors, request additional information from selected Offerors and/or negotiate terms and conditions with selected Offerors.

HACP will perform a responsibility review of the highest-ranked Offeror(s), which shall include reference and financial background checks.

HACP shall not be responsible for and will not reimburse any Offeror for any cost(s) associated with preparing a proposal.

A Proposal submitted by an Offeror does not constitute a contract, nor does it confer any rights on the Offeror to the award of a contract. A letter or other notice of award or of the intent to award shall not constitute a contract. A contract is not created until all required signatures are affixed to the contract.

Prior to contract execution of any professional service contracts which have a potential value of \$250,000.00 and greater, the selected firm may be required to appear before and present a Minority and Woman Owned Business participation plan to the City of Pittsburgh Equal Employment Opportunity Review Commission for approval. Any HACP contracts which have a potential value of \$50,000.00 and greater is subject to approval by the HACP Board of Commissioners and the selected firm may be required to appear before the HACP Board of Commissioners.

**HOUSING AUTHORITY OF THE CITY OF PITTSBURGH**

**Request for Proposals**

**AUTHORITY WIDE SITE IMPROVEMENTS**

**ATTACHMENT A**

**Form of Agreement**



HOUSING AUTHORITY OF THE CITY OF PITTSBURGH

**FORM OF AGREEMENT**

THIS AGREEMENT, made this \_\_\_\_ day of \_\_\_\_\_ in the year Two Thousand Ninteen (2019) by and between:

\_\_\_\_\_  
\_\_\_\_\_  
\_\_\_\_\_

- An individual doing business in his/her own name
- An individual doing business under a fictitious or assumed name
- A partnership
- A Corporation

(Hereinafter called the Contractor)

AND

The Housing Authority of the City of Pittsburgh (hereinafter called the Authority)  
200 Ross Street  
Pittsburgh, PA 15219

WITNESSETH: That the Contractor and the Authority, for the consideration stated herein, mutually agree as follows:

ARTICLE 1, STATEMENT OF WORK

The Contractor shall provide all labor, materials and equipment, and services necessary to perform and complete all work required in accordance with Request for Proposals 600-33-19

**Request for Proposals 600-33-19 for Authority Wide Site Improvements**

and addenda thereto numbered \_\_\_\_\_, all as prepared by \_\_\_\_\_, which said addenda are incorporated herein by reference and are a part hereof.

The work shall begin at the time stipulated in the NOTICE TO PROCEED per task order.

ARTICLE 2, THE CONTRACT PRICE

The Authority shall pay the contractor for the performance of the Contract in current fund, subject to additions and deductions as provided in each task order.

ARTICLE 3, CONTRACT DOCUMENTS

The Contract shall consist of the following component parts:

- a. This Agreement
- b. Request for Proposals 600-33-19 for Authority Wide Site Improvements
- c. Task Orders

This Agreement, together with the other documents enumerated in this Article 3 which said other documents are as fully a part of the Contract as if hereto attached or herein repeated, form the Contract. In the event that any provision in any component part of this Contract conflicts with any provision of any other component part, the provision of the component part first enumerated in this ARTICLE 3, shall govern, except as subsequent parts may establish more specific criteria or language in which case these criteria and language shall govern. The various provisions in Addenda shall be construed in the order of preference of the component part of the Contract which each modified.

SIGNED, SEALED AND DELIVERED IN \_\_\_\_\_ ORIGINAL COUNTERPARTS  
*(6 required)*

this \_\_\_\_\_ day of \_\_\_\_\_ 20\_\_\_\_\_.

---

IF THE PRINCIPAL IS AN INDIVIDUAL, SIGN HERE

**By signing this Form of Agreement, if the Housing Authority accepts and signs Contract No. 600-33-19, this contract shall be binding on both parties.**

\_\_\_\_\_  
*(Printed or Typed Name)*

\_\_\_\_\_  
*(Printed or Typed Name)*

*Witness*

{

*Principal*

{

\_\_\_\_\_  
*(Signature and Date)*

\_\_\_\_\_  
*(Signature and Date)*

---

IF THE PRINCIPAL IS A PARTNERSHIP, SIGN HERE

**By signing this Form of Agreement, if the Housing Authority accepts and signs Contract No. 600-33-19, this contract shall be binding on both parties.**

	_____		_____
	<i>(Printed or Typed Name)</i>		<i>(Printed or Typed Name)</i>
<i>Witness</i>		<i>Partner*</i>	
{	_____	{	_____
	<i>(Signature and Date)</i>		<i>(Signature and Date)</i>
	_____		_____
	<i>(Printed or Typed Name)</i>		<i>(Printed or Typed Name)</i>
<i>Witness</i>		<i>Partner*</i>	
{	_____	{	_____
	<i>(Signature and Date)</i>		<i>(Signature and Date)</i>

\* If the Bidder is a partnership, the Form of Agreement must be signed in the name of the partnership by at least two general partners, whose names and addresses must be listed on the certificate on page BF-3-P of the Bid.

---

IF THE PRINCIPAL IS A CORPORATION, SIGN HERE

**By signing this Form of Agreement, if the Housing Authority accepts and signs Contract No. 600-33-19, this contract shall be binding on both parties.**

(CORPORATE  
SEAL)

\_\_\_\_\_  
(Corporate Name)

\_\_\_\_\_  
(Printed or Typed Name)

\_\_\_\_\_  
(Printed or Typed Name)

Witness

President

V.P. \*\*

{  
\_\_\_\_\_  
(Signature and Date)

{  
\_\_\_\_\_  
(Signature and Date)

\_\_\_\_\_  
(Corporate Title)

\_\_\_\_\_  
(Corporate Title)

\*\* If the bidder is a corporation, the Form of Agreement must be executed in the Corporation's correct corporate name by its President or Vice President and attested to by its Secretary or Assistant Secretary or Treasurer or Assistant Treasurer, and the Certification of Corporate Principal (Doc. 00625) must be executed by the Secretary or Assistant Secretary.

CERTIFICATE AS TO CORPORATE PRINCIPAL

I, \_\_\_\_\_, certify that I am the  
**Secretary/Assistant Secretary** of the Corporation named a Bidder herein; that  
(circle one)

\_\_\_\_\_ who signed this Bid on behalf of the

Corporation was then \_\_\_\_\_ of said Corporation that I know his  
signature and his signature thereto is genuine; and that said Bid was duly signed, sealed and  
attested in behalf of said Corporation by authority of its governing body.

(CORPORATE  
SEAL)

\_\_\_\_\_  
(Signature and Date)

Secretary

Kim Detrick, Chief Contracting Officer

*Attest*

*Principal*

{

{

\_\_\_\_\_  
*(Signature and Date)*

\_\_\_\_\_  
*(Signature and Date)*

Manikandan Muthiah, Director of Construction and Modernization

*Approved as to*

*Contents and Costs* {

\_\_\_\_\_  
*(Signature and Date)*

Associate Counsel

*Approved as to*

*Form* {

\_\_\_\_\_  
*(Signature and Date)*

HOUSING AUTHORITY OF THE CITY OF PITTSBURGH

**CONTRACTING OFFICER CERTIFICATION**

I \_\_\_\_\_ certify that I am the Recording Secretary of the Housing Authority of the City of Pittsburgh; that \_\_\_\_\_, who signed this Contract on behalf of the Housing Authority, was then Contracting Officer of said Authority; that the said Contract was duly signed for and on behalf of the Housing Authority of the City of Pittsburgh.

\_\_\_\_\_  
Secretary (SEAL)

**EXHIBITS TO  
Form of Agreement**

**Compliance with Law.** Offeror shall comply with all Federal, State and Local laws, regulations ordinances and codes relating to the operation and activities of Authority and all Services performed pursuant to this Agreement, including, but not limited to completing the following items which shall be attached as exhibits:

- |                                     |             |
|-------------------------------------|-------------|
| (a) Non-Debarment Certificate       | (Exhibit C) |
| (b) Certification re: Lobbying      | (Exhibit D) |
| (c) Disclosure of lobbying activity | (Exhibit E) |
| (d) Conflict of Interest            | (Exhibit F) |

CERTIFICATION OF PROPOSER  
REGARDING DEBARMENT SUSPENSION AND OTHER RESPONSIBILITY MATTERS

(Proposer) \_\_\_\_\_ certifies to the best of its knowledge and belief, that it and its principals:

1. Are not presently debarred, suspended, proposed for debarment, declared ineligible or voluntarily excluded from covered transactions by any Federal department or agency;
2. Have not within a three year period preceding this bid been convicted of or had civil judgment rendered against them for commission of fraud or a criminal offense in connection with obtaining, attempting to obtain or performing a public (Federal, State or Local) transaction or contract under a public transaction: violation of Federal or State antitrust statutes or commission of embezzlement, thief, forgery, bribery, falsification or destruction of records, making false statements or receiving stolen property;
3. Are not presently indicted for or otherwise criminally or civilly charged by a governmental entity (Federal, State or Local) with commission of any of the offenses emmerated in paragraph (2) of this certification: and
4. Have not within a three year period preceding this bid had one or more public transaction (Federal, State or Local) terminated for cause or default.

If the Proposer is unable to certify to any of the statements in this certification, the Proposer shall attach an explanation to this certification.

(Proposer) \_\_\_\_\_ CERTIFIES OR AFFIRMS THE TRUTHFULNESS AND ACCURACY OF THE CONTENTS OF THE STATEMENTS SUBMITTED ON OR WITH THIS CERTIFICATION AND UNDERSTANDS THAT THE PROVISIONS OF 31 U.S.C. SECTIONS 3801 ET SEQ. ARE APPLICABLE THERETO.

\_\_\_\_\_  
Signature and Title of Authorized Official



CERTIFICATION REGARDING LOBBYING

I, \_\_\_\_\_,  
(Name and Title of Authorized Official)

Hereby Certify on Behalf of \_\_\_\_\_ that

- (1) No Federal appropriated funds have been paid or will be paid, by or on behalf of the undersigned, to any person for influencing or attempting to influence an officer or employee of an agency. A Member of Congress, and officer or employee of Congress, or an employee of a Member of Congress in connection with the awarding of any Federal contract, the making of any Federal grant, the making of any Federal loan, the entering into of any cooperative agreement, and the extension, continuation, renewal, amendment, or modification of any Federal contract, grant, loan or cooperative agreement.
- (2) If any funds other than Federal appropriated funds have been paid or will be paid to any person for influencing or attempting to influence an officer or employee of any agency, a Member of Congress, an officer or employee of Congress, or an employee of a Member of Congress in connection with this Federal contract, grant, loan, or cooperative agreement, the undersigned shall complete and submit Standard Form-LLL " Disclosure Form to Report Lobbying", in accordance with its instructions.
- (3) The undersigned shall require that the language of this certification be included in the award documents for all subawards at all tiers (including subcontracts, subgrants, and contracts under grants, loans, and cooperative agreements) and that all subrecipients shall certify and disclose accordingly.

This certification is a material representation of fact upon which reliance was placed when this transaction was made or entered into. Submission of this certification is a prerequisite for making or entering into this transaction imposed by Section 1352, Title 31, U.S. Code. Any person who fails to file the required certification shall be subject to a civil penalty of not less than \$10,000 and not more than \$100,000 for each such failure.

\_\_\_\_\_  
Signature and Title of Authorized Official

EXHIBIT E

Disclosure of Lobbying Activities

Complete this form to disclose lobbying activities pursuant to 31 U.S.C. 1352

Public Reporting Burden for this collection of information is estimated to average 30 minutes per response, including the time for reviewing instructions, researching existing data sources, gathering and maintaining the data needed and completing and reviewing the collection of information. Please do not return your completed form to the Office of Management and Budget sent it to the address provided by the sponsoring agency.

<p>1. Type of Federal Action:</p> <p><input type="checkbox"/> a. contract</p> <p><input type="checkbox"/> b. grant</p> <p><input type="checkbox"/> c. cooperative agreement</p> <p><input type="checkbox"/> d. loan</p> <p><input type="checkbox"/> e. loan guarantee</p> <p><input type="checkbox"/> f. loan insurance</p>	<p>2. Status of Federal Action:</p> <p><input type="checkbox"/> a. bid/offer/application</p> <p><input type="checkbox"/> b. initial award</p> <p><input type="checkbox"/> c. post-award</p>	<p>3. Report Type:</p> <p><input type="checkbox"/> a. initial filing</p> <p><input type="checkbox"/> b. material change</p> <p>For Material Change Only</p> <p>year _____ quarter _____</p> <p>date of last report _____</p>	
<p>4. Name and Address of Reporting Entity:</p> <p>____ Prime ____ Subawardee Tier _____, if known:</p> <p>Congressional District, if known:</p>	<p>5. If reporting entity in No. 4 if Subawardee, enter name and address of Prime.</p> <p>Congressional District, if known:</p>		
<p>6. Federal Department/Agency:</p>	<p>6. Federal Program Name/Description:</p> <p>CFDA Number, if applicable:</p>		
<p>8. Federal Action Number, if known:</p>	<p>9. Award Amount, if known:</p> <p>\$ _____</p>		
<p>10a. Name and Address of Lobbying Registrant (If individual, last name, first name, MI):</p>	<p>b. Individuals performing services (Include address if different from No. 10a) (last name, first name, MI):</p>		
<p>I. Information requested through this form is authorized by Sec 319, Pub L. 101-121, 103 Stat. 750, as amended by Sec. 10: Pub. L. 104-65, Stat 700 (31 U.S.C. 1352). This disclosure of lobbying activities is a material representation of fact upon which reliance was placed by the above when this transaction was made entered into. This disclosure is required pursuant to 31 U.S.A.C. 1352. This information will be reported to the Congress semiannually and will be available for public inspection. Any person who fails to file the required disclosure shall be subject to a civil penalty of not less than \$10,000 and not more than \$100,000 for each such failure.</p>			<p>Signature _____</p> <p>Print Name _____</p> <p>Title: _____</p> <p>Telephone No.: _____</p> <p>Date: _____</p>

Federal Use Only

Authorized for Local Reproduction  
Standard Form LLL (1/96)

## INSTRUCTIONS FOR COMPLETION OF SF-LLL DISCLOSURE OF LOBBY ACTIVITIES

This disclosure form shall be completed by the reporting entity, whether subawardee or prime Federal recipient, at the initiation or receipt of a covered Federal action, or a material change to a previous filing, pursuant to title 31 U.S.C. section 1352. The filing of a form is required for each payment or agreement to make payment of any lobby entity for influencing or attempting to influence an officer or employee of any agency, a Member of Congress, an officer or employee of Congress, or an employee of a Member of Congress in connection with a covered Federal action. Use the SF-LLL-A Continuation Sheet for additional information in the space on the form is inadequate. Complete all items that apply for both the initial filing and material change reports. Refer to the implementing guidance published by the Office of Management and Budget for additional information.

1. Identify the type of covered Federal action for which lobby activity is and/or has been secured to influence the outcome of a covered Federal action.
2. Identify the status of the covered Federal action.
3. Identify the appropriate classification of this report. If this is a follow up report caused by a material change to the information previously reported, enter the year and quarter in which the change occurred. Enter the date of the last previously submitted report by this reporting entity for this covered Federal action.
4. Enter the full name, address, city, state and zip code of the reporting entity. Include Congressional District if known. Check the appropriate classification of the reporting entity that designates if it is, or expects to be a prime or a subaward recipient. Identify the tier of the subawardee, e.g., the first subawardee of the prime is in the 1<sup>st</sup> tier. Subawards include but are not limited to subcontracts, subgrants and contract awards under grants.
5. If the organization filing the report in item 4 checks "Subawardee" then enter the full name, address, city, state and zip code of the prime Federal recipient. Include Congressional District, if known.
6. Enter the name of the Federal agency making the award or loan commitment. Include at least one organizational level below agency name, if known. For example, Department of Transportation, United States Coast Guard.
7. Enter the Federal program name or description for the covered Federal action (item 1). If known, enter the full Catalog of Federal Domestic Assistance (CFOA) number for grants, cooperation agreements, loans, and loan commitments.
8. Enter the most appropriate Federal identifying number available for the Federal action identified in item 1 (e.g., Request for Proposal (RFP) number, Invitation for Bid (IFB) number; grant announcement number; the contract, grant or loan award number, the application/proposal control number assigned by the Federal agency. Include prefixes e.g. RFP-DE-90-00).
9. For a covered Federal action where there has been an award or loan commitment by the Federal agency, enter the Federal amount of the award/loan commitment for the prime entity identified in item 4 or 5.
10. (a) Enter the full name, address, city, state and zip code of the lobbying entity engaged by the reporting entity identified in item 4 to influence the covered Federal action.  
  
(b) Enter the full names of the individual (s) performing services, and include full address if different from 10 (a). Enter Last Name, First Name, and Middle Initial (MI).
11. Enter the amount of compensation paid or reasonably expected to be paid by the reporting entity (item 4) to the lobbying entity (item 10). Indicate whether the payment has been made (actual or will be made 9planned). Check all boxes that apply. If this is a material change report, enter the cumulative amount of payment made or planned to be made.
12. Check the appropriate box (es). Check all boxes that apply. If payment is made through an in-kind contribution, specify the nature and value of the in-kind payment.
13. Check the appropriate box (es). Check all boxes that apply. If other, specify nature.
14. Provide a specific and detailed description of the services that the lobbyist has performed, or will be expected to perform, and the date (s) of any services rendered. Include all preparatory and related activity, not just time spent in actual contact with Federal Official (s) or employee (s) contacted of the officer (s) employee (s) or Member (s) of Congress that were contacted.
15. Check whether or not a SF-LLL-A Continuation Sheet (s) is attached.
16. The certifying individual shall sign and date the form, print his/her name, title, and telephone number.

Public reporting burden for this collection of information is estimated to average 30 minutes per response. Including time for reviewing instructions, searching existing data sources, gathering and maintaining the data needed, and completing and reviewing the collection of information. Send comments regarding the burden estimate or any other respect of this collection of information, including suggestions for reducing this burden, to the Office of Management and Budget, Paperwork Reduction Project (0348-004-5), Washington, D.C. 20503.

Conflicts of Interest

\_\_\_\_\_ (Contractor") certifies that:

1. No employee, officer, or agent of the Housing Authority of the City of Pittsburgh (HACP) participated in the selection, or in the award or administration of the Contractor's Agreement with HACP, which would involve a conflict of interest, real or apparent. A conflict would arise when (i) a HACP employee, officer or agent, (ii) any member of his or her immediate family, (iii) his or her parents, (iv) his or her business associates, or (v) an organization that employs, or is about to employ, any of the foregoing, receives a payment from the Contractor or any affiliate thereof, or has a financial or other interest in the Contractor or the Contractor's Agreement with HACP.
  
2. Contractor shall not enter into any contract, subcontract or agreement with any officer, agent or employee of HACP during his or her tenure not for one year thereafter shall any officer, agent or employee of HACP have any interest, direct or indirect, in the Contract Agreement including the proceeds thereof.

Date: \_\_\_\_\_

CONTRACTOR:

By: \_\_\_\_\_

Name: \_\_\_\_\_

Title: \_\_\_\_\_

**HOUSING AUTHORITY OF THE CITY OF PITTSBURGH**

**Request for Proposals**

**AUTHORITY WIDE SITE IMPROVEMENTS**

**ATTACHMENT B**

**Form of Bid**

FORM OF BID			
ITEM NO.	DESCRIPTION	UNIT PRICE/RATE	UNIT OF MEASURE
02 41 12.0010	SAW CUTTING BITUMINOUS PAVEMENT	\$	LF
02 41 12.0011	SAW CUTTING COCNCRETE PAVEMENT	\$	LF
02 41 12.0012	SAW CUTTING MISCELLANEOUS CONCRETE STRUCTURES	\$	LF
02 41 13.0011	REMOVE BITUMINOUS SURFACE LESS THAN OR EQUAL TO 6" DEPTH	\$	SY
02 41 13.0012	REMOVE BITUMINOUS SURFACE GREATER THAN 6" DEPTH	\$	SY
02 41 13.0021	REMOVE CONCRETE PAVEMENT LESS THAN OR EQUAL TO 6" DEPTH	\$	SY
02 41 13.0022	REMOVE CONCRETE PAVEMENT GREATER THAN 6" DEPTH	\$	SY
02 41 13.0030	REMOVE SUBBASE	\$	CY
02 41 13.0040	REMOVE CURB	\$	LF
02 41 13.0050	REMOVE CONCRETE OR BRICK GUTTERS	\$	SY
02 41 13.0060	REMOVE MISCELLANEOUS CONCRETE STRUCTURES	\$	CY
31 11 00.2011	CLEARING AND GRUBBING TOPSOIL REMOVAL, STOCKPILE AND DISPOSAL	\$	SY
31 11 00.2012	CLEARING AND GRUBBING TOPSOIL AND ORGANIC MATTER REMOVAL, STOCKPILE AND DISPOSAL	\$	SY
31 11 00.2013	CLEARING AND GRUBBING OBJECTIONABLE MATERIAL REMOVAL AND DISPOSAL	\$	SY
31 12 00.8101	REMOVE TREE STUMP EQUAL TO OR LESS THAN 12"	\$	EACH
31 12 00.8102	REMOVE TREE STUMP GREATER THAN 12" AND EQUAL TO OR LESS THAN 24"	\$	EACH
31 12 00.8103	GRIND TREE STUMP	\$	EACH
31 13 13.8120	REMOVE TREE EQUAL TO OR LESS THAN 12"	\$	EACH
31 13 13.8121	REMOVE TREE GREATER THAN 12" AND EQUAL TO OR LESS THAN 24"	\$	EACH
31 13 13.8122	REMOVE TREE GREATER THAN 24"	\$	EACH
31 13 16.8110	TREE TRIMMING LESS THAN 20'	\$	EACH
31 13 16.8111	TREE TRIMMING GREATER THAN 20'	\$	EACH
31 22 16.0203	GRADING EMBANKMENT AND SPOIL	\$	CY
31 23 13.0414	SUBGRADE PREPARATION	\$	SY
31 23 16.0403	GENERAL EXCAVATION AND SPOIL	\$	CY
31 23 16.0456	DITCHING	\$	CY
31 23 23.0407	BORROW	\$	CY
31 23 33.0425	TRENCH EXCAVATION	\$	CY
31 23 33.0430	SEWER EXCAVATION	\$	CY
32 01 16.0491	MILL BITUMINOUS SURFACE	\$	SY
32 01 17.0324	MANUAL BITUMINOUS PATCHING WEARING COURSE	\$	TON
32 01 17.2300	MANUAL BITUMINOUS PATCHING BINDER COURSE	\$	TON
32 01 26.0514	GRINDING OF CONCRETE PAVEMENT, SIDEWALK	\$	SY
32 05 16.7031	NO. 57 COARSE AGGREGATE	\$	CY
32 05 16.7032	NO. 8 COARSE AGGREGATE	\$	CY
32 11 23.0104	SUBBASE FOR PAVEMENT NO 2A 4" DEPTH	\$	SY

ITEM NO.	DESCRIPTION	UNIT PRICE/RATE	UNIT OF MEASURE
32 11 23.0106	SUBBASE FOR PAVEMENT NO 2A 6" DEPTH	\$	SY
32 11 23.0108	SUBBASE FOR PAVEMENT NO 2A 8" DEPTH	\$	SY
32 11 23.0110	SUBBASE FOR PAVEMENT NO 2A 10" DEPTH	\$	SY
32 11 23.0120	SUBBASE FOR PAVEMENT BY VOLUME NO 2A	\$	CY
32 11 23.0121	SUBBASE FOR PAVEMENT BY WEIGHT NO 2A	\$	TON
32 12 19.0384	1.5" WEARING COURSE BITUMINOUS PAVEMENT	\$	SY
32 12 19.6380	3.5" BINDER COURSE BITUMINOUS PAVEMENT	\$	SY
32 13 13.0200	8" REINFORCED CEMENT CONCRETE PAVEMENT	\$	SY
32 13 13.0202	10" REINFORCED CEMENT CONCRETE PAVEMENT	\$	SY
32 14 16.4130	UNIT PAVERS, BRICK SIDEWALK	\$	SY
32 14 40.4140	UNIT PAVERS, BLOCK STONE SIDEWALK	\$	SY
32 16 13.4210	CONCRETE CURB, TANGENT	\$	LF
32 16 13.4220	CONCRETE CURB, RADIUS	\$	LF
32 16 13.4230	DEPRESSED CONCRETE CURB, TANGENT	\$	LF
32 16 13.4235	DEPRESSED CONCRETE CURB, RADIUS	\$	LF
32 16 13.5001	BITUMINOUS CONCRETE CURB	\$	LF
32 16 13.6005	CONCRETE GUTTER	\$	SY
32 16 13.7350	CONCRETE CURB AND GUTTER	\$	LF
32 16 23.4110	PLAIN CEMENT CONCRETE SIDEWALK	\$	SY
32 16 23.4111	EXPOSED AGGREGATE PLAIN CEMENT CONCRETE SIDEWALK	\$	SY
32 16 23.4120	REINFORCED CEMENT CONCRETE SIDEWALK	\$	SY
32 16 23.4121	EXPOSED AGGREGATE REINFORCED CEMENT CONCRETE SIDEWALK	\$	SY
32 16 23.4600	ACCESSIBLE SIDEWALK RAMP, TANGENT	\$	SY
32 16 23.4650	ACCESSIBLE SIDEWALK RAMP, RADIUS	\$	SY
32 16 23.4700	BUILT-UP CURB RAMP	\$	TON
32 16 33.4410	PLAIN CEMENT CONCRETE DRIVEWAY	\$	SY
32 16 33.4420	REINFORCED CEMENT CONCRETE DRIVEWAY	\$	SY
32 16 33.4500	ACCESSIBLE DRIVEWAY APRON	\$	SY
32 17 13.0019	PRECAST CONCRETE PARKING BUMPERS	\$	EACH
32 17 23.1000	4" STANDARD PAVEMENT MARKINGS	\$	LF
32 17 23.1001	6" STANDARD PAVEMENT MARKINGS	\$	LF
32 17 23.1002	8" STANDARD PAVEMENT MARKINGS	\$	LF
32 17 23.1003	12" STANDARD PAVEMENT MARKINGS	\$	LF
32 17 23.1004	24" STANDARD PAVEMENT MARKINGS	\$	LF
32 17 23.4000	PAVEMENT MARKINGS, CURB	\$	LF
32 17 23.9001	REMOVE PAVEMENT MARKINGS	\$	SY
32 17 26.4850	DETECTABLE WARNING SURFACE, ACCESSIBLE RAMP ALTERATION	\$	SY
32 17 26.4900	DETECTABLE WARNING SURFACE, PAVEMENT	\$	SY
32 31 13.0001	CHAIN LINK FENCE	\$	LF
32 31 13.0722	CHAIN LINK FENCE VEHICULAR GATE	\$	EACH
32 31 13.0611	CHAIN LINK FENCE PEDESTRIAN GATE	\$	EACH

ITEM NO.	DESCRIPTION	UNIT PRICE/RATE	UNIT OF MEASURE
32 32 13.6000	RETAINING WALL, CAST IN PLACE, 8" THICK, CLASS P OR PP REINFORCED CONCRETE	\$	CY
32 32 23.8000	RETAINING WALL, SEGMENTAL	\$	SF
32 91 19.1205	BORROW TOPSOIL	\$	CY
32 92 13.0024	MULCHING	\$	TON
32 94 43.0100	TREE GRATE	\$	EACH
33 12 13.1291	PRIVATE WATER SERVICE	\$	LF
33 33 13.1237	SANITARY SEWER, HOUSE LATERAL	\$	LF
33 41 13.0001	6" THERMOPLASTIC PIPE, PADOT GROUP I, 15' MAX FILL - 1.5' MIN. COVER	\$	LF
33 41 13.0311	12" THERMOPLASTIC PIPE, PADOT GROUP I, 15' MAX FILL - 1.5' MIN. COVER	\$	LF
33 41 13.0313	18" THERMOPLASTIC PIPE, PADOT GROUP I, 15' MAX FILL - 1.5' MIN. COVER	\$	LF
33 41 13.0315	24" THERMOPLASTIC PIPE, PADOT GROUP I, 15' MAX FILL - 1.5' MIN. COVER	\$	LF
33 46 16.0100	BROKEN STONE PIPE SUBDRAIN, CURB	\$	LF
33 46 16.0200	BROKEN STONE PIPE SUBDRAIN, PAVEMENT	\$	LF
33 46 16.1010	BROKEN STONE SUBSURFACE DRAIN	\$	CY
33 49 13.0100	ALTERATION AND ADJUSTMENT OF CATCH BASINS AND INLETS	\$	LVF
33 49 13.0200	ALTERATION AND ADJUSTMENT OF MANHOLES	\$	LVF
33 49 13.1100	PARTIAL RECONSTRUCTION OF CATCH BASINS AND INLETS	\$	LVF
33 49 13.2300	CASTINGS	\$	EACH
33 49 13.2500	PADOT STANDARD MANHOLE	\$	EACH
33 49 13.2714	PADOT TYPE C CONCRETE TOP UNIT AND ADA COMPLIANT GRATE	\$	EACH
33 49 13.2734	PADOT TYPE M CONCRETE TOP UNIT ADA COMPLIANT GRATE	\$	EACH
33 49 13.2850	PADOT STANDARD INLET BOX, HEIGHT <math>\leq 10'</math>	\$	EACH
33 49 13.6061	GRADE ADJUSTMENT OF EXISTING PADOT INLET	\$	EACH
33 49 13.6062	GRADE ADJUSTMENT OF EXISTING PADOT MANHOLE	\$	EACH
33 49 13.6071	REBUILD PADOT INLET BOX	\$	LVF
33 49 13.6072	REBUILD PADOT MANHOLE	\$	LVF
34 71 13.0052	VEHICLE MEDIAN BARRIERS	\$	LF
34 71 13.0500	RESET VEHICLE GUIDE RAILS	\$	LF
34 71 13.0503	REMOVE VEHICLE GUIDE RAILS	\$	LF
34 71 13.1025	VEHICLE GUIDE RAILS	\$	LF
34 71 13.1029	VEHICLE GUIDE RAILS END TREATMENT	\$	EACH



<b>LABOR</b>		
<i>UNIT PRICE AS PER SINGLE UNIT (HOUR). RATES INCLUDE EMPLOYMENT COMPENSATION AND BENEFITS, CONTRACTOR'S OVERHEAD AND PROFIT, ETC:</i>		
SUPERINTENDENT	\$	MON-FRI HOURLY RATE
FOREMAN	\$	MON-FRI HOURLY RATE
BRICKLAYER	\$	MON-FRI HOURLY RATE
CARPENTER	\$	MON-FRI HOURLY RATE
PLUMBER	\$	MON-FRI HOURLY RATE
LABORER	\$	MON-FRI HOURLY RATE
LANDSCAPE LABORER	\$	MON-FRI HOURLY RATE
EQUIPMENT OPERATOR	\$	MON-FRI HOURLY RATE
POWER EQUIPMENT OPERATOR	\$	MON-FRI HOURLY RATE
CEMENT MASON/CONCRETE FINISHER	\$	MON-FRI HOURLY RATE
PILEDRIVERMAN	\$	MON-FRI HOURLY RATE
IRONWORKER	\$	MON-FRI HOURLY RATE
<b>MARKUP</b>		
CONTRACTOR'S MATERIAL PURCHASES - MATERIAL AT DIRECT COST PLUS	%	PERCENTAGE
<b>OVERHEAD AND PROFIT</b>		
CONTRACTOR OVERHEAD AND PROFIT ON SUBCONTRACTOR LABOR AND MATERIALS	%	PERCENTAGE
<b>EQUIPMENT</b>		
TRUCK TIME; MINIMUM 4 CU. YD. DUMP TRUCK	\$	HOURLY RATE
RATE ESCALATION - THIRD YEAR THROUGH FIFTH PERCENTAGE (%)	%	PERCENTAGE

Company Name: \_\_\_\_\_

Vendor Signature: \_\_\_\_\_

Vendor Name Printed: \_\_\_\_\_

Email: \_\_\_\_\_

Phone # \_\_\_\_\_ Fax # \_\_\_\_\_

**HOUSING AUTHORITY OF THE CITY OF PITTSBURGH**

**Request for Proposals**

**AUTHORITY WIDE SITE IMPROVEMENTS**

**ATTACHMENT C**

**Performance and Payment Bonds**

HOUSING AUTHORITY OF THE CITY OF PITTSBURGH

**PERFORMANCE BOND**

THIS BOND IS ISSUED SIMULTANEOUSLY WITH PAYMENT BOND IN FAVOR OF THE AUTHORITY CONDITIONED ON THE FULL AND FAITHFUL PERFORMANCE OF THE CONTRACT.

KNOW ALL MEN BY THESE PRESENTS, that we,

\_\_\_\_\_, as Principal, and  
*(Insert name and address of contractor exactly as it appears on Form of Agreement)*

\_\_\_\_\_, as Sureties, are held and firmly bound unto the **Housing Authority of the City of Pittsburgh**, its certain attorney, successors, or assigns (the Obligee, hereinafter called the "Authority") in the penal sum of

\_\_\_\_\_ Dollars (\$ \_\_\_\_\_)

lawful money of the United States, for the payment of which sum well and truly to be made, we bind ourselves, our heirs, personal representatives, successors, and assigns, jointly and severally, firmly by these presents:

WHEREAS, the Principal heretofore has submitted to the said Authority a certain bid, dated

\_\_\_\_\_, 20\_\_\_\_\_ (the "Bid"), for construction of  
*(Insert date of bid)*

\_\_\_\_\_  
*(Insert name of project exactly as it appears on Form of Agreement)* pursuant to specifications, drawings and other related documents constituting the Invitation for Bids (the "IFB"); and

WHEREAS, the said Authority is a "Contracting body" under provisions of Act No. 385 of the General Assembly of the Commonwealth of Pennsylvania, approved by the Governor on December 20, 1967, known and cited as the "Public Works Contractors' Bond Law of 1967" (8 P.S. 191-202) (the "Act"); and

WHEREAS, the Act, in Section 3 (a), requires that, before an award shall be made to the Principal shall furnish this Bond to the said Authority, with this Bond to become binding upon the award of a Contract to the Principal by the said Authority in accordance with the Bid; and

WHEREAS, it also is a condition of the IFB that this Bond shall be furnished by the Principal to the said Authority; and

WHEREAS, Under the Invitation for Bids, it is provided, inter alia, that if the Principal shall furnish this Bond to the said Authority, and if the said Authority shall make an award to the Principal in accordance with the Bid, then the Principal and the said Authority shall enter into a contract with respect to performance of such work (the "Contract"), the Form of Agreement for which is set forth in the IFB.

NOW, therefore, THE CONDITION OF THIS OBLIGATION IS SUCH, that if the principal shall faithfully perform the Contract on his part as of the time and in the manner therein provided and satisfy all claims and demands incurred in or for the same, or growing out of the same, or for injury or damages to persons or property in the performance thereof, and shall fully indemnify and save harmless the said Authority from any and all cost and damage which the said Authority may suffer by reason of the principal's failure to do so, and shall fully reimburse and repay the said Authority any and all outlay and expense which it incurs by reason of any such default, then this obligation shall be null and void, otherwise it shall remain in full force and virtue.

It is further understood and agreed that the principal shall guarantee for a period of one (1) year from completion date of the contract against defects in workmanship or materials in accordance with the terms of the Contract.

The said surety, for value received, hereby stipulates and agrees that no change, extension of time, alteration or addition to the terms of the Contract or to the work to be performed thereunder or the Specifications accompanying the same shall in any wise affect its obligations on this bond, and it does hereby waive notice of any such change, extension of time, alteration or addition to the terms of the Contract or to the work or to the Specifications.

SIGNED, SEALED AND DELIVERED IN \_\_\_\_\_ ORIGINAL COUNTERPARTS  
(2 required by Authority)

this \_\_\_\_\_ day of \_\_\_\_\_ 20\_\_\_\_\_.

---

IF THE PRINCIPAL IS AN INDIVIDUAL, SIGN HERE

	_____		_____
	<i>(Printed or Typed Name)</i>		<i>(Printed or Typed Name)</i>
<i>Witness</i>		<i>Principal</i>	
{		{	
	_____		_____
	<i>(Signature and Date)</i>		<i>(Signature and Date)</i>

---

IF THE PRINCIPAL IS A PARTNERSHIP, SIGN HERE

	_____ <i>(Printed or Typed Name)</i>		_____ <i>(Printed or Typed Name)</i>
<i>Witness</i>		<i>Partner*</i>	
	{		{
	_____ <i>(Signature and Date)</i>		_____ <i>(Signature and Date)</i>

	_____ <i>(Printed or Typed Name)</i>		_____ <i>(Printed or Typed Name)</i>
<i>Witness</i>		<i>Partner*</i>	
	{		{
	_____ <i>(Signature and Date)</i>		_____ <i>(Signature and Date)</i>

\* If the Bidder is a partnership, the Bond must be signed in the name of the partnership by at least two general partners, whose names and addresses must be listed on the certificate on page BF-3-P of the Bid.

---

IF THE PRINCIPAL IS A CORPORATION, SIGN HERE

*(CORPORATE  
SEAL)*

\_\_\_\_\_  
*(Corporate Name)*

*Witness*

\_\_\_\_\_  
*(Printed or Typed Name)*

\_\_\_\_\_  
*(Printed or Typed Name)*

{

*President  
V.P.\*\**

{

\_\_\_\_\_  
*(Signature and Date)*

\_\_\_\_\_  
*(Signature and Date)*

\_\_\_\_\_  
*(Corporate Title)*

\_\_\_\_\_  
*(Corporate Title)*

\*\* If the bidder is a corporation, the Bond must be executed in the Corporation's correct corporate name by its President or Vice President and attested to by its Secretary or Assistant Secretary or Treasurer or Assistant Treasurer, and the Certification of Corporate Principal below must be executed by the Secretary or Assistant Secretary.

CERTIFICATE AS TO CORPORATE PRINCIPAL

I, \_\_\_\_\_, certify that I am the  
**Secretary/Assistant Secretary** of the Corporation named a Bidder herein; that  
*(Circle one)*

\_\_\_\_\_ who signed this Bid on behalf of the

Corporation was then \_\_\_\_\_ of said Corporation that I know his signature and his signature thereto is genuine; and that said Bid was duly signed, sealed and attested in behalf of said Corporation by authority of its governing body.

*(CORPORATE  
SEAL)*

\_\_\_\_\_  
*(Signature and Date)*

SURETY SIGN HERE

(SURETY  
SEAL)

\_\_\_\_\_  
(Printed or Typed Name)

\_\_\_\_\_  
(Printed or Typed Name)

Attest  
{

\_\_\_\_\_  
(Signature and Date)

Surety \*\*\*  
{

\_\_\_\_\_  
(Signature and Date)

\*\*\*Power of attorney must be attached to this Bid Bond.

\_\_\_\_\_  
The rate of premium charged is \$ \_\_\_\_\_ per thousand.  
(To be filled in by Surety)

The total amount of premium charged is \$ \_\_\_\_\_  
(To be filled in by Surety)



HOUSING AUTHORITY OF THE CITY OF PITTSBURGH

**PAYMENT BOND  
(Labor and Materialmen's Bond)**

THIS BOND IS ISSUED SIMULTANEOUSLY WITH PERFORMANCE BOND IN FAVOR OF THE  
AUTHORITY CONDITIONED ON THE FULL AND FAITHFUL PERFORMANCE OF THE CONTRACT.

KNOW ALL MEN BY THESE PRESENTS, that we,

\_\_\_\_\_, as Principal, and  
*(Insert name and address of Contractor exactly as it appears on Form of Agreement)*

\_\_\_\_\_, as Sureties, are  
held and firmly bound unto the **Housing Authority of the City of Pittsburgh**, its certain attorney, successors, or assigns  
(the Obligee, hereinafter called the "Authority") in the penal sum of

\_\_\_\_\_ Dollars (\$ \_\_\_\_\_)

lawful money of the United States, for the payment of which sum well and truly to be made, we bind ourselves, our  
heirs, personal representatives, successors, and assigns, jointly and severally, firmly by these presents:

WHEREAS, the Principal heretofore has submitted to the said Obligee a certain bid, dated

\_\_\_\_\_, 20\_\_\_\_\_ (the "Bid"), for construction of  
*(Insert date of bid)*

\_\_\_\_\_  
*(Insert name of project exactly as it appears on Form of Agreement)*  
pursuant to specifications, drawings and other related documents constituting the Invitation for Bids (the "IFB"); and

WHEREAS, the said Authority is a "Contracting body" under provisions of Act No. 385 of the General Assembly  
of the Commonwealth of Pennsylvania, approved by the Governor on December 20, 1967, known and cited as the  
"Public Works Contractors' Bond Law of 1967" (8 P.S. 191-202) (the "Act"); and

WHEREAS, the Act, in Section 3 (a), requires that, before an award shall be made to the Principal shall furnish this  
Bond to the said Authority, with this Bond to become binding upon the award of a Contract to the Principal by the said  
Authority in accordance with the Bid; and

WHEREAS, it also is a condition of the IFB that this Bond shall be furnished by the Principal to the said Authority;  
and

WHEREAS, Under the Invitation for Bids, it is provided, inter alia, that if the Principal shall furnish this Bond to the said Authority, and if the said Authority shall make an award to the Principal in accordance with the Bid, then the Principal and the said Authority shall enter into a contract with respect to performance of such work (the "Contract"), the Form of Agreement for which is set forth in the IFB.

NOW, THEREFORE, THE CONDITION OF THIS OBLIGATION IS SUCH that if said principal and all subcontractors to whom any portion of the work provided for in said contract is sublet and all assignees of said principal and of such subcontractors shall promptly make payment for all material furnished, labor supplied or performed, rental for equipment employed, and services rendered by public utilities in or in connection with the prosecution of the work, whether or not the said material, labor, equipment or services enter into and become component parts of the work or improvement contemplated in said contract, or in any amendment or extension of or addition to said Contract, then the above obligation shall be void; otherwise to remain in full force and effect. PROVIDED, however, that this bond is subject to the following conditions and limitations.

(a) All persons who have performed labor, rendered services or furnished materials or machinery, shall have direct right of action against the principal and surety on this bond, which right of action shall be asserted in proceedings instituted in the State in which such labor was performed, services rendered or materials furnished (or where labor has been performed, services rendered or materials furnished under said Contract is more than one State, then in any such State). Insofar as permitted by the laws of such State, such right of action shall be asserted in a proceeding instituting such action and any or all other persons having claims hereunder, and any other person having a claim hereunder shall have the right to be made a party to such proceeding (but not later than one year after the complete performance of said Contract and final settlement thereof) and to have such claim adjudicated in such action and judgment rendered thereon.

(b) The surety shall not be liable hereunder for any damages or compensation recoverable under any workmen's compensation or employer's liability statute.

(c) In no event shall the surety be liable for a greater sum than the penalty of this bond, or subject to any suit, action or proceeding thereon that is instituted later than one year after the complete performance of said contract and final settlement thereof.

(d) As used herein: The term "person" refers to any individual, firm or corporation who have furnished materials or machinery or public utility services to be used on or incorporated in the work or the prosecution thereof provided for in said Contract or in any amendment or extension of or addition to said Contract, and/or to any person engaged in the prosecution of the work provided for in said Contract or in any amendment or extension of or addition to said Contract, who is an agent, servant or employee of the principal, or of any subcontractor, or of any assignee of said principal or of any subcontractor and also anyone so engaged who performs the work of a laborer or of a mechanic regardless of any contractual relationship between the principal, or any sub-contractor, or any assignee of said principal or of said subcontractor, and such laborer or mechanic, but shall not include office employees not regularly stationed at the site of the work.

The said surety, for value received, hereby stipulates and agrees that no change, extension of time, alteration or addition to the terms of the Contract, or to the work to be performed thereunder or the Specifications accompanying the same, shall in any wise affect its obligations on this bond, and it does hereby waive notice of any such change, extension of time, alteration or addition to the terms of the Contract or to the work or to the Specifications.

SIGNED, SEALED AND DELIVERED IN \_\_\_\_\_ ORIGINAL COUNTERPARTS  
*(2 required by Authority)*

this \_\_\_\_\_ day of \_\_\_\_\_ 20\_\_\_\_\_.

---

IF THE PRINCIPAL IS AN INDIVIDUAL, SIGN HERE

	_____		_____
	<i>(Printed or Typed Name)</i>		<i>(Printed or Typed Name)</i>
<i>Witness</i>		<i>Principal</i>	
	{		{
	_____		_____
	<i>(Signature and Date)</i>		<i>(Signature and Date)</i>

---

IF THE PRINCIPAL IS A PARTNERSHIP, SIGN HERE

	_____		_____
	<i>(Printed or Typed Name)</i>		<i>(Printed or Typed Name)</i>
<i>Witness</i>		<i>Partner*</i>	
	{		{
	_____		_____
	<i>(Signature and Date)</i>		<i>(Signature and Date)</i>

	_____		_____
	<i>(Printed or Typed Name)</i>		<i>(Printed or Typed Name)</i>
<i>Witness</i>		<i>Partner*</i>	
	{		{
	_____		_____
	<i>(Signature and Date)</i>		<i>(Signature and Date)</i>

\* If the Bidder is a partnership, the Bond must be signed in the name of the partnership by at least two general partners, whose names and addresses must be listed on the certificate on page BF-3-P of the Bid.

---

IF THE PRINCIPAL IS A CORPORATION, SIGN HERE

*(CORPORATE  
SEAL)*

\_\_\_\_\_  
*(Corporate Name)*

*Witness*

\_\_\_\_\_  
*(Printed or Typed Name)*

\_\_\_\_\_  
*(Printed or Typed Name)*

{

*President  
V.P.\*\**

{

\_\_\_\_\_  
*(Signature and Date)*

\_\_\_\_\_  
*(Signature and Date)*

\_\_\_\_\_  
*(Corporate Title)*

\_\_\_\_\_  
*(Corporate Title)*

\*\* If the bidder is a corporation, the Bond must be executed in the Corporation's correct corporate name by its President or Vice President and attested to by its Secretary or Assistant Secretary or Treasurer or Assistant Treasurer, and the Certification of Corporate Principal (Doc. 00625) must be executed by the Secretary or Assistant Secretary.

**CERTIFICATE AS TO CORPORATE PRINCIPAL**

I, \_\_\_\_\_, certify that I am the  
**Secretary/Assistant Secretary** of the Corporation named a Bidder herein; that  
*(Circle one)*

\_\_\_\_\_ who signed this Bid on behalf of the

Corporation was then \_\_\_\_\_ of said Corporation that I know his signature and his signature thereto is genuine; and that said Bid was duly signed, sealed and attested in behalf of said Corporation by authority of its governing body.

*(CORPORATE  
SEAL)*

\_\_\_\_\_  
*(Signature and Date)*

---

SURETY SIGN HERE

(SURETY  
SEAL)

	_____		_____
	(Printed or Typed Name)		(Printed or Typed Name)
<i>Attest</i>	{	<i>Surety</i>	{
	_____		_____
	(Signature and Date)		(Signature and Date)

---

The rate of premium charged is \$ \_\_\_\_\_ per thousand.  
(To be filled in by Surety)

The total amount of premium charged is \$ \_\_\_\_\_  
(To be filled in by Surety)

**HOUSING AUTHORITY OF THE CITY OF PITTSBURGH**

**Request for Proposals**

**AUTHORITY WIDE SITE IMPROVEMENTS**

**ATTACHMENT D**

**General Conditions for Construction Contracts - Public Housing  
Programs (HUD 5370)  
and  
Supplemental General Conditions**

# General Conditions for Construction Contracts - Public Housing Programs

U.S. Department of Housing and Urban Development  
Office of Public and Indian Housing  
OMB Approval No. 2577-0157 (exp. 3/31/2020)

**Applicability. This form is applicable to any construction/development contract greater than \$150,000.**

This form includes those clauses required by OMB's common rule on grantee procurement, implemented at HUD in 2 CFR 200, and those requirements set forth in Section 3 of the Housing and Urban Development Act of 1968 and its amendment by the Housing and Community Development Act of 1992, implemented by HUD at 24 CFR Part 135. The form is required for construction contracts awarded by Public Housing Agencies (PHAs).

The form is used by Housing Authorities in solicitations to provide necessary contract clauses. If the form were not used, HAs would be unable to enforce their contracts.

Public reporting burden for this collection of information is estimated to average 1.0 hours per response, including the time for reviewing instructions, searching existing data sources, gathering and maintaining the data needed, and completing and reviewing the collection of information. Responses to the collection of information are required to obtain a benefit or to retain a benefit.

The information requested does not lend itself to confidentiality.

HUD may not conduct or sponsor, and a person is not required to respond to a collection of information unless it displays a currently valid OMB number.

Clause		Page	Clause		Page
1.	Definitions	2	<b>Administrative Requirements</b>		
2.	Contractor's Responsibility for Work	2	25.	Contract Period	9
3.	Architect's Duties, Responsibilities and Authority	2	26.	Order of Precedence	9
4.	Other Contracts	3	27.	Payments	9
<b>Construction Requirements</b>			28.	Contract Modifications	10
5.	Preconstruction Conference and Notice to Proceed	3	29.	Changes	10
6.	Construction Progress Schedule	3	30.	Suspension of Work	11
7.	Site Investigation and Conditions Affecting the Work	3	31.	Disputes	11
8.	Differing Site Conditions	4	32.	Default	11
9.	Specifications and Drawings for Construction	4	33.	Liquidated	12
10.	As-Built Drawings	5	34.	Termination of Convenience	12
11.	Material and Workmanship	5	35.	Assignment of Contract	12
12.	Permits and Codes	5	36.	Insurance	12
13.	Health, Safety, and Accident Prevention	6	37.	Subcontracts	13
14.	Temporary Buildings and Transportation Materials	6	38.	Subcontracting with Small and Minority Firms, Women's Business Enterprise, and Labor Surplus Area Firms	13
15.	Availability and Use of Utility Services	6	39.	Equal Employment Opportunity	13
16.	Protection of Existing Vegetation, Structures, Equipment, Utilities, and Improvements	6	40.	Employment, Training, and Contracting Opportunities for Low-Income Persons, Section 3 of the Housing and Urban Development Act of 1968	14
17.	Temporary Buildings and Transportation Materials	7	41.	Interest of Members of Congress	15
18.	Clean Air and Water	7	42.	Interest of Members, Officers, or Employees and Former Members, Officers, or Employees	15
19.	Energy Efficiency	7	43.	Limitations on Payments Made to Influence	15
20.	Inspection and Acceptance of Construction	7	44.	Royalties and Patents	15
21.	Use and Possession Prior to	8	45.	Examination and Retention of Contractor's Records	15
22.	Warranty of Title	8	46.	Labor Standards-Davis-Bacon and Related Acts	15
23.	Warranty of	8	47.	Non-Federal Prevailing Wage Rates	19
24.	Prohibition Against	9	48.	Procurement of Recovered	19



---

## 1. Definitions

- (a) "Architect" means the person or other entity engaged by the PHA to perform architectural, engineering, design, and other services related to the work as provided for in the contract. When a PHA uses an engineer to act in this capacity, the terms "architect" and "engineer" shall be synonymous. The Architect shall serve as a technical representative of the Contracting Officer. The Architect's authority is as set forth elsewhere in this contract.
  - (b) "Contract" means the contract entered into between the PHA and the Contractor. It includes the forms of Bid, the Bid Bond, the Performance and Payment Bond or Bonds or other assurance of completion, the Certifications, Representations, and Other Statements of Bidders (form HUD-5370), these General Conditions of the Contract for Construction (form HUD-5370), the applicable wage rate determinations from the U.S. Department of Labor, any special conditions included elsewhere in the contract, the specifications, and drawings. It includes all formal changes to any of those documents by addendum, change order, or other modification.
  - (c) "Contracting Officer" means the person delegated the authority by the PHA to enter into, administer, and/or terminate this contract and designated as such in writing to the Contractor. The term includes any successor Contracting Officer and any duly authorized representative of the Contracting Officer also designated in writing. The Contracting Officer shall be deemed the authorized agent of the PHA in all dealings with the Contractor.
  - (d) "Contractor" means the person or other entity entering into the contract with the PHA to perform all of the work required under the contract.
  - (e) "Drawings" means the drawings enumerated in the schedule of drawings contained in the Specifications and as described in the contract clause entitled Specifications and Drawings for Construction herein.
  - (f) "HUD" means the United States of America acting through the Department of Housing and Urban Development including the Secretary, or any other person designated to act on its behalf. HUD has agreed, subject to the provisions of an Annual Contributions Contract (ACC), to provide financial assistance to the PHA, which includes assistance in financing the work to be performed under this contract. As defined elsewhere in these General Conditions or the contract documents, the determination of HUD may be required to authorize changes in the work or for release of funds to the PHA for payment to the Contractor. Notwithstanding HUD's role, nothing in this contract shall be construed to create any contractual relationship between the Contractor and HUD.
  - (g) "Project" means the entire project, whether construction or rehabilitation, the work for which is provided for in whole or in part under this contract.
  - (h) "PHA" means the Public Housing Agency organized under applicable state laws which is a party to this contract.
  - (i) "Specifications" means the written description of the technical requirements for construction and includes the criteria and tests for determining whether the requirements are met.
  - (l) "Work" means materials, workmanship, and manufacture and fabrication of components.
- (a) The Contractor shall furnish all necessary labor, materials, tools, equipment, and transportation necessary for performance of the work. The Contractor shall also furnish all necessary water, heat, light, and power not made available to the Contractor by the PHA pursuant to the clause entitled Availability and Use of Utility Services herein.
  - (b) The Contractor shall perform on the site, and with its own organization, work equivalent to at least [ ] (12 percent unless otherwise indicated) of the total amount of work to be performed under the order. This percentage may be reduced by a supplemental agreement to this order if, during performing the work, the Contractor requests a reduction and the Contracting Officer determines that the reduction would be to the advantage of the PHA.
  - (c) At all times during performance of this contract and until the work is completed and accepted, the Contractor shall directly superintend the work or assign and have on the work site a competent superintendent who is satisfactory to the Contracting Officer and has authority to act for the Contractor.
  - (d) The Contractor shall be responsible for all damages to persons or property that occur as a result of the Contractor's fault or negligence, and shall take proper safety and health precautions to protect the work, the workers, the public, and the property of others. The Contractor shall hold and save the PHA, its officers and agents, free and harmless from liability of any nature occasioned by the Contractor's performance. The Contractor shall also be responsible for all materials delivered and work performed until completion and acceptance of the entire work, except for any completed unit of work which may have been accepted under the contract.
  - (e) The Contractor shall lay out the work from base lines and bench marks indicated on the drawings and be responsible for all lines, levels, and measurements of all work executed under the contract. The Contractor shall verify the figures before laying out the work and will be held responsible for any error resulting from its failure to do so.
  - (f) The Contractor shall confine all operations (including storage of materials) on PHA premises to areas authorized or approved by the Contracting Officer.
  - (g) The Contractor shall at all times keep the work area, including storage areas, free from accumulations of waste materials. After completing the work and before final inspection, the Contractor shall (1) remove from the premises all scaffolding, equipment, tools, and materials (including rejected materials) that are not the property of the PHA and all rubbish caused by its work; (2) leave the work area in a clean, neat, and orderly condition satisfactory to the Contracting Officer; (3) perform all specified tests; and, (4) deliver the installation in complete and operating condition.
  - (h) The Contractor's responsibility will terminate when all work has been completed, the final inspection made, and the work accepted by the Contracting Officer. The Contractor will then be released from further obligation except as required by the warranties specified elsewhere in the contract.

## 3. Architect's Duties, Responsibilities, and Authority

- (a) The Architect for this contract, and any successor, shall be designated in writing by the Contracting Officer.

## 2. Contractor's Responsibility for Work

- (b) The Architect shall serve as the Contracting Officer's technical representative with respect to architectural, engineering, and design matters related to the work performed under the contract. The Architect may provide direction on contract performance. Such direction shall be within the scope of the contract and may not be of a nature which: (1) institutes additional work outside the scope of the contract; (2) constitutes a change as defined in the Changes clause herein; (3) causes an increase or decrease in the cost of the contract; (4) alters the Construction Progress Schedule; or (5) changes any of the other express terms or conditions of the contract.
- (c) The Architect's duties and responsibilities may include but shall not be limited to:
- (1) Making periodic visits to the work site, and on the basis of his/her on-site inspections, issuing written reports to the PHA which shall include all observed deficiencies. The Architect shall file a copy of the report with the Contractor's designated representative at the site;
  - (2) Making modifications in drawings and technical specifications and assisting the Contracting Officer in the preparation of change orders and other contract modifications for issuance by the Contracting Officer;
  - (3) Reviewing and making recommendations with respect to - (i) the Contractor's construction progress schedules; (ii) the Contractor's shop and detailed drawings; (iii) the machinery, mechanical and other equipment and materials or other articles proposed for use by the Contractor; and, (iv) the Contractor's price breakdown and progress payment estimates; and,
  - (4) Assisting in inspections, signing Certificates of Completion, and making recommendations with respect to acceptance of work completed under the contract.

#### 4. Other Contracts

The PHA may undertake or award other contracts for additional work at or near the site of the work under this contract. The Contractor shall fully cooperate with the other contractors and with PHA employees and shall carefully adapt scheduling and performing the work under this contract to accommodate the additional work, heeding any direction that may be provided by the Contracting Officer. The Contractor shall not commit or permit any act that will interfere with the performance of work by any other contractor or by PHA employees

### Construction Requirements

#### 5. Pre-construction Conference and Notice to Proceed

- (a) Within ten calendar days of contract execution, and prior to the commencement of work, the Contractor shall attend a preconstruction conference with representatives of the PHA, its Architect, and other interested parties convened by the PHA. The conference will serve to acquaint the participants with the general plan of the construction operation and all other requirements of the contract. The PHA will provide the Contractor with the date, time, and place of the conference.
- (b) The contractor shall begin work upon receipt of a written Notice to Proceed from the Contracting Officer or designee. The Contractor shall not begin work prior to receiving such notice.

#### 6. Construction Progress Schedule

- (a) The Contractor shall, within five days after the work commences on the contract or another period of time determined by the Contracting Officer, prepare and submit to the Contracting Officer for approval three copies of a practicable schedule showing the order in which the Contractor proposes to perform the work, and the dates on which the Contractor contemplates starting and completing the several salient features of the work (including acquiring labor, materials, and equipment). The schedule shall be in the form of a progress chart of suitable scale to indicate appropriately the percentage of work scheduled for completion by any given date during the period. If the Contractor fails to submit a schedule within the time prescribed, the Contracting Officer may withhold approval of progress payments or take other remedies under the contract until the Contractor submits the required schedule.
- (b) The Contractor shall enter the actual progress on the chart as required by the Contracting Officer, and immediately deliver three copies of the annotated schedule to the Contracting Officer. If the Contracting Officer determines, upon the basis of inspection conducted pursuant to the clause entitled Inspection and Acceptance of Construction, herein that the Contractor is not meeting the approved schedule, the Contractor shall take steps necessary to improve its progress, including those that may be required by the Contracting Officer, without additional cost to the PHA. In this circumstance, the Contracting Officer may require the Contractor to increase the number of shifts, overtime operations, days of work, and/or the amount of construction plant, and to submit for approval any supplementary schedule or schedules in chart form as the Contracting Officer deems necessary to demonstrate how the approved rate of progress will be regained.
- (c) Failure of the Contractor to comply with the requirements of the Contracting Officer under this clause shall be grounds for a determination by the Contracting Officer that the Contractor is not prosecuting the work with sufficient diligence to ensure completion within the time specified in the Contract. Upon making this determination, the Contracting Officer may terminate the Contractor's right to proceed with the work, or any separable part of it, in accordance with the Default clause of this contract.

#### 7. Site Investigation and Conditions Affecting the Work

- (a) The Contractor acknowledges that it has taken steps reasonably necessary to ascertain the nature and location of the work, and that it has investigated and satisfied itself as to the general and local conditions which can affect the work or its cost, including but not limited to, (1) conditions bearing upon transportation, disposal, handling, and storage of materials; (2) the availability of labor, water, electric power, and roads; (3) uncertainties of weather, river stages, tides, or similar physical conditions at the site; (4) the conformation and conditions of the ground; and (5) the character of equipment and facilities needed preliminary to and during work performance. The Contractor also acknowledges that it has satisfied itself as to the character, quality, and quantity of surface and subsurface materials or obstacles to be encountered insofar as this information is

reasonably ascertainable from an inspection of the site, including all exploratory work done by the PHA, as well as from the drawings and specifications made a part of this contract. Any failure of the Contractor to take the actions described and acknowledged in this paragraph will not relieve the Contractor from responsibility for estimating properly the difficulty and cost of successfully performing the work, or for proceeding to successfully perform the work without additional expense to the PHA.

- (b) The PHA assumes no responsibility for any conclusions or interpretations made by the Contractor based on the information made available by the PHA. Nor does the PHA assume responsibility for any understanding reached or representation made concerning conditions which can affect the work by any of its officers or agents before the execution of this contract, unless that understanding or representation is expressly stated in this contract.

### 8. Differing Site Conditions

- (a) The Contractor shall promptly, and before the conditions are disturbed, give a written notice to the Contracting Officer of (1) subsurface or latent physical conditions at the site which differ materially from those indicated in this contract, or (2) unknown physical conditions at the site(s), of an unusual nature, which differ materially from those ordinarily encountered and generally recognized as inhering in work of the character provided for in the contract.
- (b) The Contracting Officer shall investigate the site conditions promptly after receiving the notice. Work shall not proceed at the affected site, except at the Contractor's risk, until the Contracting Officer has provided written instructions to the Contractor. If the conditions do materially so differ and cause an increase or decrease in the Contractor's cost of, or the time required for, performing any part of the work under this contract, whether or not changed as a result of the conditions, the Contractor shall file a claim in writing to the PHA within ten days after receipt of such instructions and, in any event, before proceeding with the work. An equitable adjustment in the contract price, the delivery schedule, or both shall be made under this clause and the contract modified in writing accordingly.
- (c) No request by the Contractor for an equitable adjustment to the contract under this clause shall be allowed, unless the Contractor has given the written notice required; provided, that the time prescribed in (a) above for giving written notice may be extended by the Contracting Officer.
- (d) No request by the Contractor for an equitable adjustment to the contract for differing site conditions shall be allowed if made after final payment under this contract.

### 9. Specifications and Drawings for Construction

- (a) The Contractor shall keep on the work site a copy of the drawings and specifications and shall at all times give the Contracting Officer access thereto. Anything mentioned in the specifications and not shown on the drawings, or shown on the drawings and not mentioned in the specifications, shall be of like effect as if shown or mentioned in both. In case of difference between drawings and specifications, the specifications shall govern. In case of discrepancy in the figures, in the drawings, or in the specifications, the matter shall be

promptly submitted to the Contracting Officer, who shall promptly make a determination in writing. Any adjustment by the Contractor without such a determination shall be at its own risk and expense. The Contracting Officer shall furnish from time to time such detailed drawings and other information as considered necessary, unless otherwise provided.

- (b) Wherever in the specifications or upon the drawings the words "directed", "required", "ordered", "designated", "prescribed", or words of like import are used, it shall be understood that the "direction", "requirement", "order", "designation", or "prescription", of the Contracting Officer is intended and similarly the words "approved", "acceptable", "satisfactory", or words of like import shall mean "approved by", or "acceptable to", or "satisfactory to" the Contracting Officer, unless otherwise expressly stated.
- (c) Where "as shown" "as indicated", "as detailed", or of similar import are used, it shall be understood that the reference is made to the drawings accompanying this contract unless stated otherwise. The word "provided" as used herein shall be understood to mean "provide complete in place" that is "furnished and installed".
- (d) "Shop drawings" means drawings, submitted to the PHA by the Contractor, subcontractor, or any lower tier subcontractor, showing in detail (1) the proposed fabrication and assembly of structural elements and (2) the installation (i.e., form, fit, and attachment details) of materials of equipment. It includes drawings, diagrams, layouts, schematics, descriptive literature, illustrations, schedules, performance and test data, and similar materials furnished by the Contractor to explain in detail specific portions of the work required by the contract. The PHA may duplicate, use, and disclose in any manner and for any purpose shop drawings delivered under this contract.
- (e) If this contract requires shop drawings, the Contractor shall coordinate all such drawings, and review them for accuracy, completeness, and compliance with other contract requirements and shall indicate its approval thereon as evidence of such coordination and review. Shop drawings submitted to the Contracting Officer without evidence of the Contractor's approval may be returned for resubmission. The Contracting Officer will indicate an approval or disapproval of the shop drawings and if not approved as submitted shall indicate the PHA's reasons therefore. Any work done before such approval shall be at the Contractor's risk. Approval by the Contracting Officer shall not relieve the Contractor from responsibility for any errors or omissions in such drawings, nor from responsibility for complying with the requirements of this contract, except with respect to variations described and approved in accordance with (f) below.
- (f) If shop drawings show variations from the contract requirements, the Contractor shall describe such variations in writing, separate from the drawings, at the time of submission. If the Architect approves any such variation and the Contracting Officer concurs, the Contracting Officer shall issue an appropriate modification to the contract, except that, if the variation is minor or does not involve a change in price or in time of performance, a modification need not be issued.
- (g) It shall be the responsibility of the Contractor to make timely requests of the PHA for such large scale and full size drawings, color schemes, and other additional information, not already in his possession, which shall be

---

required in the planning and production of the work. Such requests may be submitted as the need arises, but each such request shall be filed in ample time to permit appropriate action to be taken by all parties involved so as to avoid delay.

- (h) The Contractor shall submit to the Contracting Officer for approval four copies (unless otherwise indicated) of all shop drawings as called for under the various headings of these specifications. Three sets (unless otherwise indicated) of all shop drawings, will be retained by the PHA and one set will be returned to the Contractor. As required by the Contracting Officer, the Contractor, upon completing the work under this contract, shall furnish a complete set of all shop drawings as finally approved. These drawings shall show all changes and revisions made up to the time the work is completed and accepted.
- (i) This clause shall be included in all subcontracts at any tier. It shall be the responsibility of the Contractor to ensure that all shop drawings prepared by subcontractors are submitted to the Contracting Officer.

#### 10. As-Built Drawings

- (a) "As-built drawings," as used in this clause, means drawings submitted by the Contractor or subcontractor at any tier to show the construction of a particular structure or work as actually completed under the contract. "As-built drawings" shall be synonymous with "Record drawings."
- (b) As required by the Contracting Officer, the Contractor shall provide the Contracting Officer accurate information to be used in the preparation of permanent as-built drawings. For this purpose, the Contractor shall record on one set of contract drawings all changes from the installations originally indicated, and record final locations of underground lines by depth from finish grade and by accurate horizontal offset distances to permanent surface improvements such as buildings, curbs, or edges of walks.
- (c) This clause shall be included in all subcontracts at any tier. It shall be the responsibility of the Contractor to ensure that all as-built drawings prepared by subcontractors are submitted to the Contracting Officer.

#### 11. Material and Workmanship

- (a) All equipment, material, and articles furnished under this contract shall be new and of the most suitable grade for the purpose intended, unless otherwise specifically provided in this contract. References in the contract to equipment, material, articles, or patented processes by trade name, make, or catalog number, shall be regarded as establishing a standard of quality and shall not be construed as limiting competition. The Contractor may, at its option, use any equipment, material, article, or process that, in the judgment of, and as approved by the Contracting Officer, is equal to that named in the specifications, unless otherwise specifically provided in this contract.
- (b) Approval of equipment and materials.
  - (1) The Contractor shall obtain the Contracting Officer's approval of the machinery and mechanical and other equipment to be incorporated into the work. When requesting approval, the Contractor shall furnish to the Contracting Officer the name of the manufacturer, the model number, and other information concerning the performance, capacity, nature, and rating of the

machinery and mechanical and other equipment. When required by this contract or by the Contracting Officer, the Contractor shall also obtain the Contracting Officer's approval of the material or articles which the Contractor contemplates incorporating into the work. When requesting approval, the Contractor shall provide full information concerning the material or articles. Machinery, equipment, material, and articles that do not have the required approval shall be installed or used at the risk of subsequent rejection.

- (2) When required by the specifications or the Contracting Officer, the Contractor shall submit appropriately marked samples (and certificates related to them) for approval at the Contractor's expense, with all shipping charges prepaid. The Contractor shall label, or otherwise properly mark on the container, the material or product represented, its place of origin, the name of the producer, the Contractor's name, and the identification of the construction project for which the material or product is intended to be used.
- (3) Certificates shall be submitted in triplicate, describing each sample submitted for approval and certifying that the material, equipment or accessory complies with contract requirements. The certificates shall include the name and brand of the product, name of manufacturer, and the location where produced.
- (4) Approval of a sample shall not constitute a waiver of the PHA right to demand full compliance with contract requirements. Materials, equipment and accessories may be rejected for cause even though samples have been approved.
- (5) Wherever materials are required to comply with recognized standards or specifications, such specifications shall be accepted as establishing the technical qualities and testing methods, but shall not govern the number of tests required to be made nor modify other contract requirements. The Contracting Officer may require laboratory test reports on items submitted for approval or may approve materials on the basis of data submitted in certificates with samples. Check tests will be made on materials delivered for use only as frequently as the Contracting Officer determines necessary to insure compliance of materials with the specifications. The Contractor will assume all costs of retesting materials which fail to meet contract requirements and/or testing materials offered in substitution for those found deficient.
- (6) After approval, samples will be kept in the Project office until completion of work. They may be built into the work after a substantial quantity of the materials they represent has been built in and accepted.
- (c) Requirements concerning lead-based paint. The Contractor shall comply with the requirements concerning lead-based paint contained in the Lead-Based Paint Poisoning Prevention Act (42 U.S.C. 4821-4846) as implemented by 24 CFR Part 35.

#### 12. Permits and Codes

- (a) The Contractor shall give all notices and comply with all applicable laws, ordinances, codes, rules and regulations. Notwithstanding the requirement of the Contractor to comply with the drawings and specifications in the contract, all work installed shall comply with all applicable codes and regulations as amended by any

waivers. Before installing the work, the Contractor shall examine the drawings and the specifications for compliance with applicable codes and regulations bearing on the work and shall immediately report any discrepancy it may discover to the Contracting Officer. Where the requirements of the drawings and specifications fail to comply with the applicable code or regulation, the Contracting Officer shall modify the contract by change order pursuant to the clause entitled Changes herein to conform to the code or regulation.

- (b) The Contractor shall secure and pay for all permits, fees, and licenses necessary for the proper execution and completion of the work. Where the PHA can arrange for the issuance of all or part of these permits, fees and licenses, without cost to the Contractor, the contract amount shall be reduced accordingly.

### 13. Health, Safety, and Accident Prevention

- (a) In performing this contract, the Contractor shall:
  - (1) Ensure that no laborer or mechanic shall be required to work in surroundings or under working conditions which are unsanitary, hazardous, or dangerous to his/her health and/or safety as determined under construction safety and health standards promulgated by the Secretary of Labor by regulation;
  - (2) Protect the lives, health, and safety of other persons;
  - (3) Prevent damage to property, materials, supplies, and equipment; and,
  - (4) Avoid work interruptions.
- (b) For these purposes, the Contractor shall:
  - (1) Comply with regulations and standards issued by the Secretary of Labor at 29 CFR Part 1926. Failure to comply may result in imposition of sanctions pursuant to the Contract Work Hours and Safety Standards Act (Public Law 91-54, 83 Stat. 96), 40 U.S.C. 3701 et seq.; and
  - (2) Include the terms of this clause in every subcontract so that such terms will be binding on each subcontractor.
- (c) The Contractor shall maintain an accurate record of exposure data on all accidents incident to work performed under this contract resulting in death, traumatic injury, occupational disease, or damage to property, materials, supplies, or equipment, and shall report this data in the manner prescribed by 29 CFR Part 1904.
- (d) The Contracting Officer shall notify the Contractor of any noncompliance with these requirements and of the corrective action required. This notice, when delivered to the Contractor or the Contractor's representative at the site of the work, shall be deemed sufficient notice of the noncompliance and corrective action required. After receiving the notice, the Contractor shall immediately take corrective action. If the Contractor fails or refuses to take corrective action promptly, the Contracting Officer may issue an order stopping all or part of the work until satisfactory corrective action has been taken. The Contractor shall not base any claim or request for equitable adjustment for additional time or money on any stop order issued under these circumstances.
- (e) The Contractor shall be responsible for its subcontractors' compliance with the provisions of this clause. The Contractor shall take such action with respect to any subcontract as the PHA, the Secretary of Housing and Urban Development, or the Secretary of Labor shall direct as a means of enforcing such provisions.

### 14. Temporary Heating

The Contractor shall provide and pay for temporary heating, covering, and enclosures necessary to properly protect all work and materials against damage by dampness and cold, to dry out the work, and to facilitate the completion of the work. Any permanent heating equipment used shall be turned over to the PHA in the condition and at the time required by the specifications.

### 15. Availability and Use of Utility Services

- (a) The PHA shall make all reasonably required amounts of utilities available to the Contractor from existing outlets and supplies, as specified in the contract. Unless otherwise provided in the contract, the amount of each utility service consumed shall be charged to or paid for by the Contractor at prevailing rates charged to the PHA or, where the utility is produced by the PHA, at reasonable rates determined by the Contracting Officer. The Contractor shall carefully conserve any utilities furnished without charge.
- (b) The Contractor, at its expense and in a manner satisfactory to the Contracting Officer, shall install and maintain all necessary temporary connections and distribution lines, and all meters required to measure the amount of each utility used for the purpose of determining charges. Before final acceptance of the work by the PHA, the Contractor shall remove all the temporary connections, distribution lines, meters, and associated paraphernalia.

### 16. Protection of Existing Vegetation, Structures, Equipment, Utilities, and Improvements

- (a) The Contractor shall preserve and protect all structures, equipment, and vegetation (such as trees, shrubs, and grass) on or adjacent to the work site, which are not to be removed under this contract, and which do not unreasonably interfere with the work required under this contract.
- (b) The Contractor shall only remove trees when specifically authorized to do so, and shall avoid damaging vegetation that will remain in place. If any limbs or branches of trees are broken during performance of this contract, or by the careless operation of equipment, or by workmen, the Contractor shall trim those limbs or branches with a clean cut and paint the cut with a tree-pruning compound as directed by the Contracting Officer.
- (c) The Contractor shall protect from damage all existing improvements and utilities (1) at or near the work site and (2) on adjacent property of a third party, the locations of which are made known to or should be known by the Contractor. Prior to disturbing the ground at the construction site, the Contractor shall ensure that all underground utility lines are clearly marked.
- (d) The Contractor shall shore up, brace, underpin, secure, and protect as necessary all foundations and other parts of existing structures adjacent to, adjoining, and in the vicinity of the site, which may be affected by the excavations or other operations connected with the construction of the project.
- (e) Any equipment temporarily removed as a result of work under this contract shall be protected, cleaned, and replaced in the same condition as at the time of award of this contract.

- (f) New work which connects to existing work shall correspond in all respects with that to which it connects and/or be similar to existing work unless otherwise required by the specifications.
- (g) No structural members shall be altered or in any way weakened without the written authorization of the Contracting Officer, unless such work is clearly specified in the plans or specifications.
- (h) If the removal of the existing work exposes discolored or unfinished surfaces, or work out of alignment, such surfaces shall be refinished, or the material replaced as necessary to make the continuous work uniform and harmonious. This, however, shall not be construed to require the refinishing or reconstruction of dissimilar finishes previously exposed, or finished surfaces in good condition, but in different planes or on different levels when brought together by the removal of intervening work, unless such refinishing or reconstruction is specified in the plans or specifications.
- (i) The Contractor shall give all required notices to any adjoining or adjacent property owner or other party before the commencement of any work.
- (j) The Contractor shall indemnify and save harmless the PHA from any damages on account of settlement or the loss of lateral support of adjoining property, any damages from changes in topography affecting drainage, and from all loss or expense and all damages for which the PHA may become liable in consequence of such injury or damage to adjoining and adjacent structures and their premises.
- (k) The Contractor shall repair any damage to vegetation, structures, equipment, utilities, or improvements, including those that are the property of a third party, resulting from failure to comply with the requirements of this contract or failure to exercise reasonable care in performing the work. If the Contractor fails or refuses to repair the damage promptly, the Contracting Officer may have the necessary work performed and charge the cost to the Contractor.

#### 17. Temporary Buildings and Transportation of Materials

- (a) Temporary buildings (e.g., storage sheds, shops, offices, sanitary facilities) and utilities may be erected by the Contractor only with the approval of the Contracting Officer and shall be built with labor and materials furnished by the Contractor without expense to the PHA. The temporary buildings and utilities shall remain the property of the Contractor and shall be removed by the Contractor at its expense upon completion of the work. With the written consent of the Contracting Officer, the buildings and utilities may be abandoned and need not be removed.
- (b) The Contractor shall, as directed by the Contracting Officer, use only established roadways, or use temporary roadways constructed by the Contractor when and as authorized by the Contracting Officer. When materials are transported in prosecuting the work, vehicles shall not be loaded beyond the loading capacity recommended by the manufacturer of the vehicle or prescribed by any federal, state, or local law or regulation. When it is necessary to cross curbs or sidewalks, the Contractor shall protect them from damage. The Contractor shall repair or pay for the repair of any damaged curbs, sidewalks, or roads.

#### 18. Clean Air and Water

The contractor shall comply with the Clean Air Act, as amended, 42 USC 7401 et seq., the Federal Water Pollution Control Water Act, as amended, 33 U.S.C. 1251 et seq., and standards issued pursuant thereto in the facilities in which this contract is to be performed.

#### 19. Energy Efficiency

The Contractor shall comply with mandatory standards and policies relating to energy efficiency which are contained in the energy conservation plan issued in compliance with the Energy Policy and Conservation Act (Pub.L. 94-163) for the State in which the work under the contract is performed.

#### 20. Inspection and Acceptance of Construction

- (a) Definitions. As used in this clause -
  - (1) "Acceptance" means the act of an authorized representative of the PHA by which the PHA approves and assumes ownership of the work performed under this contract. Acceptance may be partial or complete.
  - (2) "Inspection" means examining and testing the work performed under the contract (including, when appropriate, raw materials, equipment, components, and intermediate assemblies) to determine whether it conforms to contract requirements.
  - (3) "Testing" means that element of inspection that determines the properties or elements, including functional operation of materials, equipment, or their components, by the application of established scientific principles and procedures.
- (b) The Contractor shall maintain an adequate inspection system and perform such inspections as will ensure that the work performed under the contract conforms to contract requirements. All work is subject to PHA inspection and test at all places and at all reasonable times before acceptance to ensure strict compliance with the terms of the contract.
- (c) PHA inspections and tests are for the sole benefit of the PHA and do not: (1) relieve the Contractor of responsibility for providing adequate quality control measures; (2) relieve the Contractor of responsibility for loss or damage of the material before acceptance; (3) constitute or imply acceptance; or, (4) affect the continuing rights of the PHA after acceptance of the completed work under paragraph (j) below.
- (d) The presence or absence of the PHA inspector does not relieve the Contractor from any contract requirement, nor is the inspector authorized to change any term or condition of the specifications without the Contracting Officer's written authorization. All instructions and approvals with respect to the work shall be given to the Contractor by the Contracting Officer.
- (e) The Contractor shall promptly furnish, without additional charge, all facilities, labor, and material reasonably needed for performing such safe and convenient inspections and tests as may be required by the Contracting Officer. The PHA may charge to the Contractor any additional cost of inspection or test when work is not ready at the time specified by the Contractor for inspection or test, or when prior rejection makes reinspection or retest necessary. The PHA shall perform all inspections and tests in a manner that will not unnecessarily delay the work. Special, full size, and performance tests shall be performed as described in the contract.

- (f) The PHA may conduct routine inspections of the construction site on a daily basis.
- (g) The Contractor shall, without charge, replace or correct work found by the PHA not to conform to contract requirements, unless the PHA decides that it is in its interest to accept the work with an appropriate adjustment in contract price. The Contractor shall promptly segregate and remove rejected material from the premises.
- (h) If the Contractor does not promptly replace or correct rejected work, the PHA may (1) by contract or otherwise, replace or correct the work and charge the cost to the Contractor, or (2) terminate for default the Contractor's right to proceed.
- (i) If any work requiring inspection is covered up without approval of the PHA, it must, if requested by the Contracting Officer, be uncovered at the expense of the Contractor. If at any time before final acceptance of the entire work, the PHA considers it necessary or advisable, to examine work already completed by removing or tearing it out, the Contractor, shall on request, promptly furnish all necessary facilities, labor, and material. If such work is found to be defective or nonconforming in any material respect due to the fault of the Contractor or its subcontractors, the Contractor shall defray all the expenses of the examination and of satisfactory reconstruction. If, however, such work is found to meet the requirements of the contract, the Contracting Officer shall make an equitable adjustment to cover the cost of the examination and reconstruction, including, if completion of the work was thereby delayed, an extension of time.
- (j) The Contractor shall notify the Contracting Officer, in writing, as to the date when in its opinion all or a designated portion of the work will be substantially completed and ready for inspection. If the Architect determines that the state of preparedness is as represented, the PHA will promptly arrange for the inspection. Unless otherwise specified in the contract, the PHA shall accept, as soon as practicable after completion and inspection, all work required by the contract or that portion of the work the Contracting Officer determines and designates can be accepted separately. Acceptance shall be final and conclusive except for latent defects, fraud, gross mistakes amounting to fraud, or the PHA's right under any warranty or guarantee.

## 21. Use and Possession Prior to Completion

- (a) The PHA shall have the right to take possession of or use any completed or partially completed part of the work. Before taking possession of or using any work, the Contracting Officer shall furnish the Contractor a list of items of work remaining to be performed or corrected on those portions of the work that the PHA intends to take possession of or use. However, failure of the Contracting Officer to list any item of work shall not relieve the Contractor of responsibility for complying with the terms of the contract. The PHA's possession or use shall not be deemed an acceptance of any work under the contract.
- (b) While the PHA has such possession or use, the Contractor shall be relieved of the responsibility for (1) the loss of or damage to the work resulting from the PHA's possession or use, notwithstanding the terms of the clause entitled Permits and Codes herein; (2) all maintenance costs on the areas occupied; and, (3) furnishing heat, light, power, and water used in the areas

occupied without proper remuneration therefore. If prior possession or use by the PHA delays the progress of the work or causes additional expense to the Contractor, an equitable adjustment shall be made in the contract price or the time of completion, and the contract shall be modified in writing accordingly.

## 22. Warranty of Title

The Contractor warrants good title to all materials, supplies, and equipment incorporated in the work and agrees to deliver the premises together with all improvements thereon free from any claims, liens or charges, and agrees further that neither it nor any other person, firm or corporation shall have any right to a lien upon the premises or anything appurtenant thereto.

## 23. Warranty of Construction

- (a) In addition to any other warranties in this contract, the Contractor warrants, except as provided in paragraph (j) of this clause, that work performed under this contract conforms to the contract requirements and is free of any defect in equipment, material, or workmanship performed by the Contractor or any subcontractor or supplier at any tier. This warranty shall continue for a period of \_\_\_\_\_ (one year unless otherwise indicated) from the date of final acceptance of the work. If the PHA takes possession of any part of the work before final acceptance, this warranty shall continue for a period of (one year unless otherwise indicated) from the date that the PHA takes possession.
- (b) The Contractor shall remedy, at the Contractor's expense, any failure to conform, or any defect. In addition, the Contractor shall remedy, at the Contractor's expense, any damage to PHA-owned or controlled real or personal property when the damage is the result of—
  - (1) The Contractor's failure to conform to contract requirements; or
  - (2) Any defects of equipment, material, workmanship or design furnished by the Contractor.
- (c) The Contractor shall restore any work damaged in fulfilling the terms and conditions of this clause. The Contractor's warranty with respect to work repaired or replaced will run for (one year unless otherwise indicated) from the date of repair or replacement.
- (d) The Contracting Officer shall notify the Contractor, in writing, within a reasonable time after the discovery of any failure, defect or damage.
- (e) If the Contractor fails to remedy any failure, defect, or damage within a reasonable time after receipt of notice, the PHA shall have the right to replace, repair or otherwise remedy the failure, defect, or damage at the Contractor's expense.
- (f) With respect to all warranties, express or implied, from subcontractors, manufacturers, or suppliers for work performed and materials furnished under this contract, the Contractor shall:
  - (1) Obtain all warranties that would be given in normal commercial practice;
  - (2) Require all warranties to be executed in writing, for the benefit of the PHA; and,
  - (3) Enforce all warranties for the benefit of the PHA.
- (g) In the event the Contractor's warranty under paragraph (a) of this clause has expired, the PHA may bring suit at its own expense to enforce a subcontractor's, manufacturer's or supplier's warranty.

- (h) Unless a defect is caused by the negligence of the Contractor or subcontractor or supplier at any tier, the Contractor shall not be liable for the repair of any defect of material or design furnished by the PHA nor for the repair of any damage that results from any defect in PHA furnished material or design.
- (i) Notwithstanding any provisions herein to the contrary, the establishment of the time periods in paragraphs (a) and (c) above relate only to the specific obligation of the Contractor to correct the work, and have no relationship to the time within which its obligation to comply with the contract may be sought to be enforced, nor to the time within which proceedings may be commenced to establish the Contractor's liability with respect to its obligation other than specifically to correct the work.
- (j) This warranty shall not limit the PHA's rights under the Inspection and Acceptance of Construction clause of this contract with respect to latent defects, gross mistakes or fraud.

**24. Prohibition Against Liens**

The Contractor is prohibited from placing a lien on the PHA's property. This prohibition shall apply to all subcontractors at any tier and all materials suppliers.

**Administrative Requirements**

**25. Contract Period**

this contract within \_\_\_\_\_ calendar days of the effective date of the contract, or within the time schedule established in the notice to proceed issued by the Contracting Officer. \* To be determined by Task Order.

**26. Order of Provisions**

In the event of a conflict between these General Conditions and the Specifications, the General Conditions shall prevail. In the event of a conflict between the contract and any applicable state or local law or regulation, the state or local law or regulation shall prevail; provided that such state or local law or regulation does not conflict with, or is less restrictive than applicable federal law, regulation, or Executive Order. In the event of such a conflict, applicable federal law, regulation, and Executive Order shall prevail.

**27. Payments**

- (a) The PHA shall pay the Contractor the price as provided in this contract.
- (b) The PHA shall make progress payments approximately every 30 days as the work proceeds, on estimates of work accomplished which meets the standards of quality established under the contract, as approved by the Contracting Officer. The PHA may, subject to written determination and approval of the Contracting Officer, make more frequent payments to contractors which are qualified small businesses.
- (c) Before the first progress payment under this contract, the Contractor shall furnish, in such detail as requested by the Contracting Officer, a breakdown of the total contract price showing the amount included therein for each principal category of the work, which shall substantiate the payment amount requested in order to provide a

- basis for determining progress payments. The breakdown shall be approved by the Contracting Officer and must be acceptable to HUD. If the contract covers more than one project, the Contractor shall furnish a separate breakdown for each. The values and quantities employed in making up this breakdown are for determining the amount of progress payments and shall not be construed as a basis for additions to or deductions from the contract price. The Contractor shall prorate its overhead and profit over the construction period of the contract.
- (d) The Contractor shall submit, on forms provided by the PHA, periodic estimates showing the value of the work performed during each period based upon the approved

submitted not later than \_\_\_\_\_ days in advance of the date set for payment and are subject to correction and revision as required. The estimates must be approved by the Contracting Officer with the concurrence of the Architect prior to payment. If the contract covers more than one project, the Contractor shall furnish a separate progress payment estimate for each.

- (e) Along with each request for progress payments and the required estimates, the Contractor shall furnish the following certification, or payment shall not be made: I hereby certify, to the best of my knowledge and belief, that:
  - (1) The amounts requested are only for performance in accordance with the specifications, terms, and conditions of the contract;
  - (2) Payments to subcontractors and suppliers have been made from previous payments received under the contract, and timely payments will be made from the proceeds of the payment covered by this certification, in accordance with subcontract agreements; and,
  - (3) This request for progress payments does not include any amounts which the prime contractor intends to withhold or retain from a subcontractor or supplier in accordance with the terms and conditions of the subcontract.

\_\_\_\_\_  
Name:

\_\_\_\_\_  
Title:

\_\_\_\_\_  
Date:

- (f) Except as otherwise provided in State law, the PHA shall retain ten (10) percent of the amount of progress payments until completion and acceptance of all work under the contract; except, that if upon completion of 50 percent of the work, the Contracting Officer, after consulting with the Architect, determines that the Contractor's performance and progress are satisfactory, the PHA may make the remaining payments in full for the work subsequently completed. If the Contracting Officer subsequently determines that the Contractor's performance and progress are unsatisfactory, the PHA shall reinstate the ten (10) percent (or other percentage as provided in State law) retainage until such time as the Contracting Officer determines that performance and progress are satisfactory.
- (g) The Contracting Officer may authorize material delivered on the site and preparatory work done to be taken into consideration when computing progress payments.



Material delivered to the Contractor at locations other than the site may also be taken into consideration if the Contractor furnishes satisfactory evidence that (1) it has acquired title to such material; (2) the material is properly stored in a bonded warehouse, storage yard, or similar suitable place as may be approved by the Contracting Officer; (3) the material is insured to cover its full value; and (4) the material will be used to perform this contract. Before any progress payment which includes delivered material is made, the Contractor shall furnish such documentation as the Contracting Officer may require to assure the protection of the PHA's interest in such materials. The Contractor shall remain responsible for such stored material notwithstanding the transfer of title to the PHA.

- (h) All material and work covered by progress payments made shall, at the time of payment become the sole property of the PHA, but this shall not be construed as (1) relieving the Contractor from the sole responsibility for all material and work upon which payments have been made or the restoration of any damaged work; or, (2) waiving the right of the PHA to require the fulfillment of all of the terms of the contract. In the event the work of the Contractor has been damaged by other contractors or persons other than employees of the PHA in the course of their employment, the Contractor shall restore such damaged work without cost to the PHA and to seek redress for its damage only from those who directly caused it.
- (i) The PHA shall make the final payment due the Contractor under this contract after (1) completion and final acceptance of all work; and (2) presentation of release of all claims against the PHA arising by virtue of this contract, other than claims, in stated amounts, that the Contractor has specifically excepted from the operation of the release. Each such exception shall embrace no more than one claim, the basis and scope of which shall be clearly defined. The amounts for such excepted claims shall not be included in the request for final payment. A release may also be required of the assignee if the Contractor's claim to amounts payable under this contract has been assigned.
- (j) Prior to making any payment, the Contracting Officer may require the Contractor to furnish receipts or other evidence of payment from all persons performing work and supplying material to the Contractor, if the Contracting Officer determines such evidence is necessary to substantiate claimed costs.
- (k) The PHA shall not; (1) determine or adjust any claims for payment or disputes arising there under between the Contractor and its subcontractors or material suppliers; or, (2) withhold any moneys for the protection of the subcontractors or material suppliers. The failure or refusal of the PHA to withhold moneys from the Contractor shall in no wise impair the obligations of any surety or sureties under any bonds furnished under this contract.

## 28. Contract Modifications

- (a) Only the Contracting Officer has authority to modify any term or condition of this contract. Any contract modification shall be authorized in writing.
- (b) The Contracting Officer may modify the contract unilaterally (1) pursuant to a specific authorization stated in a contract clause (e.g., Changes); or (2) for administrative matters which do not change the rights or

responsibilities of the parties (e.g., change in the PHA address). All other contract modifications shall be in the form of supplemental agreements signed by the Contractor and the Contracting Officer.

- (c) When a proposed modification requires the approval of HUD prior to its issuance (e.g., a change order that exceeds the PHA's approved threshold), such modification shall not be effective until the required approval is received by the PHA.

## 29. Changes

- (a) The Contracting Officer may, at any time, without notice to the sureties, by written order designated or indicated to be a change order, make changes in the work within the general scope of the contract including changes:
  - (1) In the specifications (including drawings and designs);
  - (2) In the method or manner of performance of the work;
  - (3) PHA-furnished facilities, equipment, materials, services, or site; or,
  - (4) Directing the acceleration in the performance of the work.
- (b) Any other written order or oral order (which, as used in this paragraph (b), includes direction, instruction, interpretation, or determination) from the Contracting Officer that causes a change shall be treated as a change order under this clause; provided, that the Contractor gives the Contracting Officer written notice stating (1) the date, circumstances and source of the order and (2) that the Contractor regards the order as a change order.
- (c) Except as provided in this clause, no order, statement or conduct of the Contracting Officer shall be treated as a change under this clause or entitle the Contractor to an equitable adjustment.
- (d) If any change under this clause causes an increase or decrease in the Contractor's cost of, or the time required for the performance of any part of the work under this contract, whether or not changed by any such order, the Contracting Officer shall make an equitable adjustment and modify the contract in writing. However, except for a adjustment based on defective specifications, no proposal for any change under paragraph (b) above shall be allowed for any costs incurred more than 20 days (5 days for oral orders) before the Contractor gives written notice as required. In the case of defective specifications for which the PHA is responsible, the equitable adjustment shall include any increased cost reasonably incurred by the Contractor in attempting to comply with the defective specifications.
- (e) The Contractor must assert its right to an adjustment under this clause within 30 days after (1) receipt of a written change order under paragraph (a) of this clause, or (2) the furnishing of a written notice under paragraph (b) of this clause, by submitting a written statement describing the general nature and the amount of the proposal. If the facts justify it, the Contracting Officer may extend the period for submission. The proposal may be included in the notice required under paragraph (b) above. No proposal by the Contractor for an equitable adjustment shall be allowed if asserted after final payment under this contract.
- (f) The Contractor's written proposal for equitable adjustment shall be submitted in the form of a lump sum proposal supported with an itemized breakdown of all increases and decreases in the contract in at least the following details:

- (1) Direct Costs. Materials (list individual items, the quantity and unit cost of each, and the aggregate cost); Transportation and delivery costs associated with materials; Labor breakdowns by hours or unit costs (identified with specific work to be performed); Construction equipment exclusively necessary for the change; Costs of preparation and/ or revision to shop drawings resulting from the change; Worker's Compensation and Public Liability Insurance; Employment taxes under FICA and FUTA; and, Bond Costs when size of change warrants revision.
- (2) Indirect Costs. Indirect costs may include overhead, general and administrative expenses, and fringe benefits not normally treated as direct costs.
- (3) Profit. The amount of profit shall be negotiated and may vary according to the nature, extent, and complexity of the work required by the change. The allowability of the direct and indirect costs shall be determined in accordance with the Contract Cost Principles and Procedures for Commercial Firms in Part 31 of the Federal Acquisition Regulation (48 CFR 1-31), as implemented by HUD Handbook 2210.18, in effect on the date of this contract. The Contractor shall not be allowed a profit on the profit received by any subcontractor. Equitable adjustments for deleted work shall include a credit for profit and may include a credit for indirect costs. On proposals covering both increases and decreases in the amount of the contract, the application of indirect costs and profit shall be on the net-change in direct costs for the Contractor or subcontractor performing the work.
- (g) The Contractor shall include in the proposal its request for time extension (if any), and shall include sufficient information and dates to demonstrate whether and to what extent the change will delay the completion of the contract in its entirety.
- (h) The Contracting Officer shall act on proposals within 30 days after their receipt, or notify the Contractor of the date when such action will be taken.
- (i) Failure to reach an agreement on any proposal shall be a dispute under the clause entitled Disputes herein. Nothing in this clause, however, shall excuse the Contractor from proceeding with the contract as changed.
- (j) Except in an emergency endangering life or property, no change shall be made by the Contractor without a prior order from the Contracting Officer.

### 30. Suspension of Work

- (a) The Contracting Officer may order the Contractor in writing to suspend, delay, or interrupt all or any part of the work of this contract for the period of time that the Contracting Officer determines appropriate for the convenience of the PHA.
- (b) If the performance of all or any part of the work is, for an unreasonable period of time, suspended, delayed, or interrupted (1) by an act of the Contracting Officer in the administration of this contract, or (2) by the Contracting Officer's failure to act within the time specified (or within a reasonable time if not specified) in this contract an adjustment shall be made for any increase in the cost of performance of the contract (excluding profit) necessarily caused by such unreasonable suspension, delay, or interruption and the contract modified in writing accordingly. However, no adjustment shall be made under this clause for any suspension, delay, or interruption to the extent that performance would have

been so suspended, delayed, or interrupted by any other cause, including the fault or negligence of the Contractor or for which any equitable adjustment is provided for or excluded under any other provision of this contract.

- (c) A claim under this clause shall not be allowed (1) for any costs incurred more than 20 days before the Contractor shall have notified the Contracting Officer in writing of the act or failure to act involved (but this requirement shall not apply as to a claim resulting from a suspension order); and, (2) unless the claim, in an amount stated, is asserted in writing as soon as practicable after the termination of the suspension, delay, or interruption, but not later than the date of final payment under the contract.

### 31. Disputes

- (a) "Claim," as used in this clause, means a written demand or written assertion by one of the contracting parties seeking, as a matter of right, the payment of money in a sum certain, the adjustment or interpretation of contract terms, or other relief arising under or relating to the contract. A claim arising under the contract, unlike a claim relating to the contract, is a claim that can be resolved under a contract clause that provides for the relief sought by the claimant. A voucher, invoice, or other routine request for payment that is not in dispute when submitted is not a claim. The submission may be converted to a claim by complying with the requirements of this clause, if it is disputed either as to liability or amount or is not acted upon in a reasonable time.
- (b) Except for disputes arising under the clauses entitled Labor Standards - Davis Bacon and Related Acts, herein, all disputes arising under or relating to this contract, including any claims for damages for the alleged breach thereof which are not disposed of by agreement, shall be resolved under this clause.
- (c) All claims by the Contractor shall be made in writing and submitted to the Contracting Officer for a written decision. A claim by the PHA against the Contractor shall be subject to a written decision by the Contracting Officer.
- (d) The Contracting Officer shall, within 60 (unless otherwise indicated) days after receipt of the request, decide the claim or notify the Contractor of the date by which the decision will be made.
- (e) The Contracting Officer's decision shall be final unless the Contractor (1) appeals in writing to a higher level in the PHA in accordance with the PHA's policy and procedures, (2) refers the appeal to an independent mediator or arbitrator, or (3) files suit in a court of competent jurisdiction. Such appeal must be made within (30 unless otherwise indicated) days after receipt of the Contracting Officer's decision.
- (f) The Contractor shall proceed diligently with performance of this contract, pending final resolution of any request for relief, claim, appeal, or action arising under or relating to the contract, and comply with any decision of the Contracting Officer.

### 32. Default

- (a) If the Contractor refuses or fails to prosecute the work, or any separable part thereof, with the diligence that will insure its completion within the time specified in this contract, or any extension thereof, or fails to complete said work within this time, the Contracting Officer may, by written notice to the Contractor, terminate the right to

proceed with the work (or separable part of the work) that has been delayed. In this event, the PHA may take over the work and complete it, by contract or otherwise, and may take possession of and use any materials, equipment, and plant on the work site necessary for completing the work. The Contractor and its sureties shall be liable for any damage to the PHA resulting from the Contractor's refusal or failure to complete the work within the specified time, whether or not the Contractor's right to proceed with the work is terminated. This liability includes any increased costs incurred by the PHA in completing the work.

- (b) The Contractor's right to proceed shall not be terminated or the Contractor charged with damages under this clause if—
- (1) The delay in completing the work arises from unforeseeable causes beyond the control and without the fault or negligence of the Contractor. Examples of such causes include (i) acts of God, or of the public enemy, (ii) acts of the PHA or other governmental entity in either its sovereign or contractual capacity, (iii) acts of another contractor in the performance of a contract with the PHA, (iv) fires, (v) floods, (vi) epidemics, (vii) quarantine restrictions, (viii) strikes, (ix) freight embargoes, (x) unusually severe weather, or (xi) delays of subcontractors or suppliers at any tier arising from unforeseeable causes beyond the control and without the fault or negligence of both the Contractor and the subcontractors or suppliers; and
  - (2) The Contractor, within days (10 days unless otherwise indicated) from the beginning of such delay (unless extended by the Contracting Officer) notifies the Contracting Officer in writing of the causes of delay. The Contracting Officer shall ascertain the facts and the extent of the delay. If, in the judgment of the Contracting Officer, the findings of fact warrant such action, time for completing the work shall be extended by written modification to the contract. The findings of the Contracting Officer shall be reduced to a written decision which shall be subject to the provisions of the Disputes clause of this contract.
- (c) If, after termination of the Contractor's right to proceed, it is determined that the Contractor was not in default, or that the delay was excusable, the rights and obligations of the parties will be the same as if the termination had been for convenience of the PHA.

### 33. Liquidated Damages

- (a) If the Contractor fails to complete the work within the time specified in the contract, or any extension, as specified in the clause entitled Default of this contract, the Contractor shall pay to the PHA as liquidated damages, the sum of \$ \_\_\_\_\_ [Contracting Officer insert amount] for each day of delay. If different completion dates are specified in the contract for separate parts or stages of the work, the amount of liquidated damages shall be assessed on those parts or stages which are delayed. To the extent that the Contractor's delay or nonperformance is excused under another clause in this contract, liquidated damages shall not be due the PHA. The Contractor remains liable for damages caused other than by delay.
- (b) If the PHA terminates the Contractor's right to proceed, the resulting damage will consist of liquidated damages until such reasonable time as may be required for final

completion of the work together with any increased costs occasioned the PHA in completing the work.

- (c) If the PHA does not terminate the Contractor's right to proceed, the resulting damage will consist of liquidated damages until the work is completed or accepted.

### 34. Termination for Convenience

- (a) The Contracting Officer may terminate this contract in whole, or in part, whenever the Contracting Officer determines that such termination is in the best interest of the PHA. Any such termination shall be effected by delivery to the Contractor of a Notice of Termination specifying the extent to which the performance of the work under the contract is terminated, and the date upon which such termination becomes effective.
- (b) If the performance of the work is terminated, either in whole or in part, the PHA shall be liable to the Contractor for reasonable and proper costs resulting from such termination upon the receipt by the PHA of a properly presented claim setting out in detail: (1) the total cost of the work performed to date of termination less the total amount of contract payments made to the Contractor; (2) the cost (including reasonable profit) of settling and paying claims under subcontracts and material orders for work performed and materials and supplies delivered to the site, payment for which has not been made by the PHA to the Contractor or by the Contractor to the subcontractor or supplier; (3) the cost of preserving and protecting the work already performed until the PHA or assignee takes possession thereof or assumes responsibility therefore; (4) the actual or estimated cost of legal and accounting services reasonably necessary to prepare and present the termination claim to the PHA; and (5) an amount constituting a reasonable profit on the value of the work performed by the Contractor.
- (c) The Contracting Officer will act on the Contractor's claim within days (60 days unless otherwise indicated) of receipt of the Contractor's claim.
- (d) Any disputes with regard to this clause are expressly made subject to the provisions of the Disputes clause of this contract.

### 35. Assignment of Contract

The Contractor shall not assign or transfer any interest in this contract; except that claims for monies due or to become due from the PHA under the contract may be assigned to a bank, trust company, or other financial institution. Such assignments of claims shall only be made with the written concurrence of the Contracting Officer. If the Contractor is a partnership, this contract shall inure to the benefit of the surviving or remaining member(s) of such partnership as approved by the Contracting Officer.

### 36. Insurance

- (a) Before commencing work, the Contractor and each subcontractor shall furnish the PHA with certificates of insurance showing the following insurance is in force and will insure all operations under the Contract:
- (1) Workers' Compensation, in accordance with state or Territorial Workers' Compensation laws.
  - (2) Commercial General Liability with a combined single limit for bodily injury and property damage of not less than \$ \_\_\_\_\_ [Contracting Officer insert amount]

per occurrence to protect the Contractor and each subcontractor against claims for bodily injury or death and damage to the property of others. This shall cover the use of all equipment, hoists, and vehicles on the site(s) not covered by Automobile Liability under (3) below. If the Contractor has a "claims made" policy, then the following additional requirements apply: the policy must provide a "retroactive date" which must be on or before the execution date of the Contract; and the extended reporting period may not be less than five years following the completion date of the Contract.

- (3) Automobile Liability on owned and non-owned motor vehicles used on the site(s) or in connection therewith for a combined single limit for bodily injury and property damage of not less than \$ \_\_\_\_\_ [Contracting Officer insert amount] per occurrence.
- (b) Before commencing work, the Contractor shall furnish the PHA with a certificate of insurance evidencing that Builder's Risk (fire and extended coverage) Insurance on all work in place and/or materials stored at the building site(s), including foundations and building equipment, is in force. The Builder's Risk Insurance shall be for the benefit of the Contractor and the PHA as their interests may appear and each shall be named in the policy or policies as an insured. The Contractor in installing equipment supplied by the PHA shall carry insurance on such equipment from the time the Contractor takes possession thereof until the Contract work is accepted by the PHA. The Builder's Risk Insurance need not be carried on excavations, piers, footings, or foundations until such time as work on the superstructure is started. It need not be carried on landscape work. Policies shall furnish coverage at all times for the full cash value of all completed construction, as well as materials in place and/or stored at the site(s), whether or not partial payment has been made by the PHA. The Contractor may terminate this insurance on buildings as of the date taken over for occupancy by the PHA. The Contractor is not required to carry Builder's Risk Insurance for modernization work which does not involve structural alterations or additions and where the PHA's existing fire and extended coverage policy can be endorsed to include such work.
- (c) All insurance shall be carried with companies which are financially responsible and admitted to do business in the State in which the project is located. If any such insurance is due to expire during the construction period, the Contractor (including subcontractors, as applicable) shall not permit the coverage to lapse and shall furnish evidence of coverage to the Contracting Officer. All certificates of insurance, as evidence of coverage, shall provide that no coverage may be canceled or non-renewed by the insurance company until at least 30 days prior written notice has been given to the Contracting Officer.

### 37. Subcontracts

- (a) Definitions. As used in this contract -
- (1) "Subcontract" means any contract, purchase order, or other purchase agreement, including modifications and change orders to the foregoing, entered into by a subcontractor to furnish supplies, materials, equipment, and services for the performance of the prime contract or a subcontract.

(2) "Subcontractor" means any supplier, vendor, or firm that furnishes supplies, materials, equipment, or services to or for the Contractor or another subcontractor.

- (b) The Contractor shall not enter into any subcontract with any subcontractor who has been temporarily denied participation in a HUD program or who has been suspended or debarred from participating in contracting programs by any agency of the United States Government or of the state in which the work under this contract is to be performed.
- (c) The Contractor shall be as fully responsible for the acts or omissions of its subcontractors, and of persons either directly or indirectly employed by them as for the acts or omissions of persons directly employed by the Contractor.
- (d) The Contractor shall insert appropriate clauses in all subcontracts to bind subcontractors to the terms and conditions of this contract insofar as they are applicable to the work of subcontractors.
- (e) Nothing contained in this contract shall create any contractual relationship between any subcontractor and the PHA or between the subcontractor and HUD.

### 38. Subcontracting with Small and Minority Firms, Women's Business Enterprise, and Labor Surplus Area Firms

The Contractor shall take the following steps to ensure that, whenever possible, subcontracts are awarded to small business firms, minority firms, women's business enterprises, and labor surplus area firms:

- (a) Placing qualified small and minority businesses and women's business enterprises on solicitation lists;
- (b) Ensuring that small and minority businesses and women's business enterprises are solicited whenever they are potential sources;
- (c) Dividing total requirements, when economically feasible, into smaller tasks or quantities to permit maximum participation by small and minority businesses and women's business enterprises;
- (d) Establishing delivery schedules, where the requirements of the contract permit, which encourage participation by small and minority businesses and women's business enterprises; and
- (e) Using the services and assistance of the U.S. Small Business Administration, the Minority Business Development Agency of the U.S. Department of Commerce, and State and local governmental small business agencies.

### 39. Equal Employment Opportunity

During the performance of this contract, the Contractor agrees as follows:

- (a) The Contractor shall not discriminate against any employee or applicant for employment because of race, color, religion, sex, national origin, or handicap.
- (b) The Contractor shall take affirmative action to ensure that applicants are employed, and that employees are treated during employment without regard to their race, color, religion, sex, national origin, or handicap. Such action shall include, but not be limited to, (1) employment, (2) upgrading, (3) demotion, (4) transfer, (5) recruitment or recruitment advertising, (6) layoff or termination, (7) rates of pay or other forms of compensation, and (8) selection for training, including apprenticeship.

- (c) The Contractor shall post in conspicuous places available to employees and applicants for employment the notices to be provided by the Contracting Officer that explain this clause.
- (d) The Contractor shall, in all solicitations or advertisements for employees placed by or on behalf of the Contractor, state that all qualified applicants will receive consideration for employment without regard to race, color, religion, sex, national origin, or handicap.
- (e) The Contractor shall send, to each labor union or representative of workers with which it has a collective bargaining agreement or other contract or understanding, the notice to be provided by the Contracting Officer advising the labor union or workers' representative of the Contractor's commitments under this clause, and post copies of the notice in conspicuous places available to employees and applicants for employment.
- (f) The Contractor shall comply with Executive Order 11246, as amended, and the rules, regulations, and orders of the Secretary of Labor.
- (g) The Contractor shall furnish all information and reports required by Executive Order 11246, as amended, Section 503 of the Rehabilitation Act of 1973, as amended, and by rules, regulations, and orders of the Secretary of Labor, or pursuant thereto. The Contractor shall permit access to its books, records, and accounts by the Secretary of Labor for purposes of investigation to ascertain compliance with such rules, regulations, and orders.
- (h) In the event of a determination that the Contractor is not in compliance with this clause or any rule, regulation, or order of the Secretary of Labor, this contract may be canceled, terminated, or suspended in whole or in part, and the Contractor may be declared ineligible for further Government contracts, or Federally assisted construction contracts under the procedures authorized in Executive Order 11246, as amended. In addition, sanctions may be imposed and remedies invoked against the Contractor as provided in Executive Order 11246, as amended, the rules, regulations, and orders of the Secretary of Labor, or as otherwise provided by law.
- (i) The Contractor shall include the terms and conditions of this clause in every subcontract or purchase order unless exempted by the rules, regulations, or orders of the Secretary of Labor issued under Executive Order 11246, as amended, so that these terms and conditions will be binding upon each subcontractor or vendor. The Contractor shall take such action with respect to any subcontract or purchase order as the Secretary of Housing and Urban Development or the Secretary of Labor may direct as a means of enforcing such provisions, including sanctions for noncompliance; provided that if the Contractor becomes involved in, or is threatened with, litigation with a subcontractor or vendor as a result of such direction, the Contractor may request the United States to enter into the litigation to protect the interests of the United States.
- (j) Compliance with the requirements of this clause shall be to the maximum extent consistent with, but not in derogation of, compliance with section 7(b) of the Indian Self-Determination and Education Assistance Act and the Indian Preference clause of this contract.
- 40. Employment, Training, and Contracting Opportunities for Low-Income Persons, Section 3 of the Housing and Urban Development Act of 1968.**
- (a) The work to be performed under this contract is subject to the requirements of section 3 of the Housing and Urban Development Act of 1968, as amended, 12 U.S.C. 1701u (section 3). The purpose of section 3 is to ensure that employment and other economic opportunities generated by HUD assistance or HUD-assisted projects covered by section 3, shall, to the greatest extent feasible, be directed to low- and very low-income persons, particularly persons who are recipients of HUD assistance for housing.
- (b) The parties to this contract agree to comply with HUD's regulations in 24 CFR Part 135, which implement section 3. As evidenced by their execution of this contract, the parties to this contract certify that they are under no contractual or other impediment that would prevent them from complying with the Part 135 regulations.
- (c) The contractor agrees to send to each labor organization or representative of workers with which the contractor has a collective bargaining agreement or other understanding, if any, a notice advising the labor organization or workers' representative of the contractor's commitments under this section 3 clause, and will post copies of the notice in conspicuous places at the work site where both employees and applicants for training and employment positions can see the notice. The notice shall describe the section 3 preference, shall set forth minimum number and job titles subject to hire, availability of apprenticeship and training positions, the qualifications for each; and the name and location of the person(s) taking applications for each of the positions; and the anticipated date the work shall begin.
- (d) The contractor agrees to include this section 3 clause in every subcontract subject to compliance with regulations in 24 CFR Part 135, and agrees to take appropriate action, as provided in an applicable provision of the subcontract or in this section 3 clause, upon a finding that the subcontractor is in violation of the regulations in 24 CFR Part 135. The contractor will not subcontract with any subcontractor where the contractor has notice or knowledge that the subcontractor has been found in violation of the regulations in 24 CFR Part 135.
- (e) The contractor will certify that any vacant employment positions, including training positions, that are filled (1) after the contractor is selected but before the contract is executed, and (2) with persons other than those to whom the regulations of 24 CFR Part 135 require employment opportunities to be directed, were not filled to circumvent the contractor's obligations under 24 CFR Part 135.
- (f) Noncompliance with HUD's regulations in 24 CFR Part 135 may result in sanctions, termination of this contract for default, and debarment or suspension from future HUD assisted contracts.
- (g) With respect to work performed in connection with section 3 covered Indian housing assistance, section 7(b) of the Indian Self-Determination and Education Assistance Act (25 U.S.C. 450e) also applies to the work to be performed under this contract. Section 7(b) requires that to the greatest extent feasible (i) preference and opportunities for training and employment shall be given to Indians, and (ii) preference in the award of contracts and subcontracts shall be given to Indian organizations and Indian-owned Economic Enterprises. Parties to this contract that are subject to the provisions of section 3 and section 7(b) agree to comply with section 3 to the maximum extent feasible, but not in derogation of compliance with section 7(b).

---

#### 41. Interest of Members of Congress

No member of or delegate to the Congress of the United States of America shall be admitted to any share or part of this contract or to any benefit that may arise therefrom.

#### 42. Interest of Members, Officers, or Employees and Former Members, Officers, or Employees

No member, officer, or employee of the PHA, no member of the governing body of the locality in which the project is situated, no member of the governing body of the locality in which the PHA was activated, and no other public official of such locality or localities who exercises any functions or responsibilities with respect to the project, shall, during his or her tenure, or for one year thereafter, have any interest, direct or indirect, in this contract or the proceeds thereof.

#### 43. Limitations on Payments made to Influence Certain Federal Financial Transactions

- (a) The Contractor agrees to comply with Section 1352 of Title 31, United States Code which prohibits the use of Federal appropriated funds to pay any person for influencing or attempting to influence an officer or employee of any agency, a Member of Congress, and officer or employee of Congress, or an employee of a Member of Congress in connection with any of the following covered Federal actions: the awarding of any Federal contract; the making of any Federal grant; the making of any Federal loan; the entering into of any cooperative agreement; or the modification of any Federal contract, grant, loan, or cooperative agreement.
- (b) The Contractor further agrees to comply with the requirement of the Act to furnish a disclosure (OMB Standard Form LLL, Disclosure of Lobbying Activities) if any funds other than Federal appropriated funds (including profit or fee received under a covered Federal transaction) have been paid, or will be paid, to any person for influencing or attempting to influence an officer or employee of any agency, a Member of Congress, an officer or employee of Congress, or an employee of a Member of Congress in connection with a Federal contract, grant, loan, or cooperative agreement.

#### 44. Royalties and Patents

The Contractor shall pay all royalties and license fees. It shall defend all suits or claims for infringement of any patent rights and shall save the PHA harmless from loss on account thereof; except that the PHA shall be responsible for all such loss when a particular design, process or the product of a particular manufacturer or manufacturers is specified and the Contractor has no reason to believe that the specified design, process, or product is an infringement. If, however, the Contractor has reason to believe that any design, process or product specified is an infringement of a patent, the Contractor shall promptly notify the Contracting Officer. Failure to give such notice shall make the Contractor responsible for resultant loss.

#### 45. Examination and Retention of Contractor's Records

- (a) The PHA, HUD, or Comptroller General of the United States, or any of their duly authorized representatives shall, until 3 years after final payment under this contract, have access to and the right to examine any of the Contractor's directly pertinent books, documents, papers, or other records involving transactions related to this contract for the purpose of making audit, examination, excerpts, and transcriptions.
- (b) The Contractor agrees to include in first-tier subcontracts under this contract a clause substantially the same as paragraph (a) above. "Subcontract," as used in this clause, excludes purchase orders not exceeding \$10,000.
- (c) The periods of access and examination in paragraphs (a) and (b) above for records relating to (1) appeals under the Disputes clause of this contract, (2) litigation or settlement of claims arising from the performance of this contract, or (3) costs and expenses of this contract to which the PHA, HUD, or Comptroller General or any of their duly authorized representatives has taken exception shall continue until disposition of such appeals, litigation, claims, or exceptions.

#### 46. Labor Standards - Davis-Bacon and Related Acts

If the total amount of this contract exceeds \$2,000, the Federal labor standards set forth in the clause below shall apply to the development or construction work to be performed under the contract.

- (a) Minimum Wages.
- (1) All laborers and mechanics employed under this contract in the development or construction of the project(s) involved will be paid unconditionally and not less often than once a week, and without subsequent deduction or rebate on any account (except such payroll deductions as are permitted by regulations issued by the Secretary of Labor under the Copeland Act (29 CFR Part 3)), the full amount of wages and bona fide fringe benefits (or cash equivalents thereof) due at time of payment computed at rates not less than those contained in the wage determination of the Secretary of Labor which is attached hereto and made a part hereof, regardless of any contractual relationship which may be alleged to exist between the Contractor and such laborers and mechanics. Contributions made or costs reasonably anticipated for bona fide fringe benefits under Section 1(b)(2) of the Davis-Bacon Act on behalf of laborers or mechanics are considered wages paid to such laborers or mechanics, subject to the provisions of 29 CFR 5.5(a)(1)(iv); also, regular contributions made or costs incurred for more than a weekly period (but not less often than quarterly) under plans, funds, or programs which cover the regular weekly period, are deemed to be constructively made or incurred during such weekly period. Such laborers and mechanics shall be paid the appropriate wage rate and fringe benefits in the wage determination for the classification of work actually performed, without regard to skill, except as provided in 29 CFR 5.5(a)(4). Laborers or mechanics performing work in more than one classification may be compensated at the rate specified for each classification for the time actually worked therein; provided, that the employer's payroll records accurately set forth the time spent in each classification in which work is performed. The wage determination (including any additional classification and wage rates conformed under 29 CFR 5.5(a)(1)(ii) and the Davis-Bacon poster (WH-1321) shall

---

be posted at all times by the Contractor and its subcontractors at the site of the work in a prominent and accessible place where it can be easily seen by the workers.

- (2) (i) Any class of laborers or mechanics, including helpers, which is not listed in the wage determination and which is to be employed under the contract shall be classified in conformance with the wage determination. HUD shall approve an additional classification and wage rate and fringe benefits therefor only when all the following criteria have been met: (A) The work to be performed by the classification requested is not performed by a classification in the wage determination; and (B) The classification is utilized in the area by the construction industry; and (C) The proposed wage rate, including any bona fide fringe benefits, bears a reasonable relationship to the wage rates contained in the wage determination.
- (ii) If the Contractor and the laborers and mechanics to be employed in the classification (if known), or their representatives, and HUD or its designee agree on the classification and wage rate (including the amount designated for fringe benefits where appropriate), a report of the action taken shall be sent by HUD or its designee to the Administrator of the Wage and Hour Division, Employee Standards Administration, U.S. Department of Labor, Washington, DC 20210. The Administrator, or an authorized representative, will approve, modify, or disapprove every additional classification action within 30 days of receipt and so advise HUD or its designee or will notify HUD or its designee within the 30-day period that additional time is necessary.
- (iii) In the event the Contractor, the laborers or mechanics to be employed in the classification or their representatives, and HUD or its designee do not agree on the proposed classification and wage rate (including the amount designated for fringe benefits, where appropriate), HUD or its designee shall refer the questions, including the views of all interested parties and the recommendation of HUD or its designee, to the Administrator of the Wage and Hour Division for determination. The Administrator, or an authorized representative, will issue a determination within 30 days of receipt and so advise HUD or its designee or will notify HUD or its designee within the 30-day period that additional time is necessary.
- (iv) The wage rate (including fringe benefits where appropriate) determined pursuant to subparagraphs (a)(2)(ii) or (iii) of this clause shall be paid to all workers performing work in the classification under this contract from the first day on which work is performed in classification.
- (3) Whenever the minimum wage rate prescribed in the contract for a class of laborers or mechanics includes a fringe benefit which is not expressed as an hourly rate, the Contractor shall either pay the benefit as stated in the wage determination or shall pay another bona fide fringe benefit or an hourly cash equivalent thereof.
- (4) If the Contractor does not make payments to a trustee or other third person, the Contractor may consider as part of the wages of any laborer or mechanic the

amount of any costs reasonably anticipated in providing bona fide fringe benefits under a plan or program; provided, that the Secretary of Labor has found, upon the written request of the Contractor, that the applicable standards of the Davis-Bacon Act have been met. The Secretary of Labor may require the Contractor to set aside in a separate account assets for the meeting of obligations under the plan or program.

- (b) Withholding of funds. HUD or its designee shall, upon its own action or upon written request of an authorized representative of the Department of Labor, withhold or cause to be withheld from the Contractor under this contract or any other Federal contract with the same prime Contractor, or any other Federally-assisted contract subject to Davis-Bacon prevailing wage requirements, which is held by the same prime Contractor, so much of the accrued payments or advances as may be considered necessary to pay laborers and mechanics, including apprentices, trainees, and helpers, employed by the Contractor or any subcontractor the full amount of wages required by the contract. In the event of failure to pay any laborer or mechanic, including any apprentice, trainee, or helper, employed or working in the construction or development of the project, all or part of the wages required by the contract, HUD or its designee may, after written notice to the Contractor, take such action as may be necessary to cause the suspension of any further payment, advance, or guarantee of funds until such violations have ceased. HUD or its designee may, after written notice to the Contractor, disburse such amounts withheld for and on account of the Contractor or subcontractor to the respective employees to whom they are due.
- (c) Payrolls and basic records.
- (1) Payrolls and basic records relating thereto shall be maintained by the Contractor during the course of the work and preserved for a period of three years thereafter for all laborers and mechanics working in the construction or development of the project. Such records shall contain the name, address, and social security number of each such worker, his or her correct classification, hourly rates of wages paid (including rates of contributions or costs anticipated for bona fide fringe benefits or cash equivalents thereof of the types described in section 1(b)(2)(B) of the Davis-Bacon Act), daily and weekly number of hours worked, deductions made, and actual wages paid. Whenever the Secretary of Labor has found, under 29 CFR 5.5(a)(1)(iv), that the wages of any laborer or mechanic include the amount of costs reasonably anticipated in providing benefits under a plan or program described in section 1(b)(2)(B) of the Davis-Bacon Act, the Contractor shall maintain records which show that the commitment to provide such benefits is enforceable, that the plan or program is financially responsible, and that the plan or program has been communicated in writing to the laborers or mechanics affected, and records which show the costs anticipated or the actual cost incurred in providing such benefits. Contractors employing apprentices or trainees under approved programs shall maintain written evidence of the registration of apprenticeship programs and certification of trainee programs, the registration of the apprentices and trainees, and the ratios and wage rates prescribed in the applicable programs.

- (2) (i) The Contractor shall submit weekly for each week in which any contract work is performed a copy of all payrolls to the Contracting Officer for transmission to HUD or its designee. The payrolls submitted shall set out accurately and completely all of the information required to be maintained under subparagraph (c)(1) of this clause. This information may be submitted in any form desired. Optional Form WH-347 (Federal Stock Number 029-005-00014-1) is available for this purpose and may be purchased from the Superintendent of Documents, U.S. Government Printing Office, Washington, D.C. 20402. The Contractor is responsible for the submission of copies of payrolls by all subcontractors. (Approved by the Office of Management and Budget under OMB Control Number 1214-0149.)
- (ii) Each payroll submitted shall be accompanied by a "Statement of Compliance," signed by the Contractor or subcontractor or his or her agent who pays or supervises the payment of the persons employed under the contract and shall certify the following:
- (A) That the payroll for the payroll period contains the information required to be maintained under paragraph (c) (1) of this clause and that such information is correct and complete;
- (B) That each laborer or mechanic (including each helper, apprentice, and trainee) employed on the contract during the payroll period has been paid the full weekly wages earned, without rebate, either directly or indirectly, and that no deductions have been made either directly or indirectly from the full wages earned, other than permissible deductions as set forth in 29 CFR Part 3; and
- (C) That each laborer or mechanic has been paid not less than the applicable wage rates and fringe benefits or cash equivalents for the classification of work performed, as specified in the applicable wage determination incorporated into the contract.
- (iii) The weekly submission of a properly executed certification set forth on the reverse side of Optional Form WH-347 shall satisfy the requirements for submission of the "Statement of Compliance" required by subparagraph (c)(2)(ii) of this clause.
- (iv) The falsification of any of the above certifications may subject the Contractor or subcontractor to civil or criminal prosecution under Section 1001 of Title 18 and Section 3729 of Title 31 of the United States Code.
- (3) The Contractor or subcontractor shall make the records required under subparagraph (c)(1) available for inspection, copying, or transcription by authorized representatives of HUD or its designee, the Contracting Officer, or the Department of Labor and shall permit such representatives to interview employees during working hours on the job. If the Contractor or subcontractor fails to submit the required records or to make them available, HUD or its designee may, after written notice to the Contractor, take such action as may be necessary to cause the suspension of any further payment, advance, or guarantee of funds. Furthermore, failure to submit the required records upon request or to

make such records available may be grounds for debarment action pursuant to 29 CFR 5.12.

- (d) (1) Apprentices. Apprentices will be permitted to work at less than the predetermined rate for the work they performed when they are employed pursuant to and individually registered in a bona fide apprenticeship program registered with the U.S. Department of Labor, Employment and Training Administration, Office of Apprenticeship and Training, Employer and Labor Services (OATELS), or with a State Apprenticeship Agency recognized by OATELS, or if a person is employed in his or her first 90 days of probationary employment as an apprentice in such an apprenticeship program, who is not individually registered in the program, but who has been certified by OATELS or a State Apprenticeship Agency (where appropriate) to be eligible for probationary employment as an apprentice. The allowable ratio of apprentices to journeymen on the job site in any craft classification shall not be greater than the ratio permitted to the Contractor as to the entire work force under the registered program. Any worker listed on a payroll at an apprentice wage rate, who is not registered or otherwise employed as stated in this paragraph, shall be paid not less than the applicable wage rate on the wage determination for the classification of work actually performed. In addition, any apprentice performing work on the job site in excess of the ratio permitted under the registered program shall be paid not less than the applicable wage rate on the wage determination for the work actually performed. Where a contractor is performing construction on a project in a locality other than that in which its program is registered, the ratios and wage rates (expressed in percentages of the journeyman's hourly rate) specified in the Contractor's or subcontractor's registered program shall be observed. Every apprentice must be paid at not less than the rate specified in the registered program for the apprentice's level of progress, expressed as a percentage of the journeyman hourly rate specified in the applicable wage determination. Apprentices shall be paid fringe benefits in accordance with the provisions of the apprenticeship program. If the apprenticeship program does not specify fringe benefits, apprentices must be paid the full amount of fringe benefits listed on the wage determination for the applicable classification. If the Administrator of the Wage and Hour Division determines that a different practice prevails for the applicable apprentice classification, fringes shall be paid in accordance with that determination. In the event OATELS, or a State Apprenticeship Agency recognized by OATELS, withdraws approval of an apprenticeship program, the Contractor will no longer be permitted to utilize apprentices at less than the applicable predetermined rate for the work performed until an acceptable program is approved.
- (2) Trainees. Except as provided in 29 CFR 5.16, trainees will not be permitted to work at less than the predetermined rate for the work performed unless they are employed pursuant to and individually registered in a program which has received prior approval, evidenced by formal certification by the U.S. Department of Labor, Employment and Training Administration. The ratio of trainees to journeymen on the job site shall not be greater than permitted under



the plan approved by the Employment and Training Administration. Every trainee must be paid at not less than the rate specified in the approved program for the trainee's level of progress, expressed as a percentage of the journeyman hourly rate specified in the applicable wage determination. Trainees shall be paid fringe benefits in accordance with the provisions of the trainee program. If the trainee program does not mention fringe benefits, trainees shall be paid the full amount of fringe benefits listed in the wage determination unless the Administrator of the Wage and Hour Division determines that there is an apprenticeship program associated with the corresponding journeyman wage rate in the wage determination which provides for less than full fringe benefits for apprentices. Any employee listed on the payroll at a trainee rate who is not registered and participating in a training plan approved by the Employment and Training Administration shall be paid not less than the applicable wage rate in the wage determination for the classification of work actually performed. In addition, any trainee performing work on the job site in excess of the ratio permitted under the registered program shall be paid not less than the applicable wage rate in the wage determination for the work actually performed. In the event the Employment and Training Administration withdraws approval of a training program, the Contractor will no longer be permitted to utilize trainees at less than the applicable predetermined rate for the work performed until an acceptable program is approved.

- (3) Equal employment opportunity. The utilization of apprentices, trainees, and journeymen under this clause shall be in conformity with the equal employment opportunity requirements of Executive Order 11246, as amended, and 29 CFR Part 30.
- (e) Compliance with Copeland Act requirements. The Contractor shall comply with the requirements of 29 CFR Part 3, which are hereby incorporated by reference in this contract.
- (f) Contract termination; debarment. A breach of this contract clause may be grounds for termination of the contract and for debarment as a Contractor and a subcontractor as provided in 29 CFR 5.12.
- (g) Compliance with Davis-Bacon and related Act requirements. All rulings and interpretations of the Davis-Bacon and related Acts contained in 29 CFR Parts 1, 3, and 5 are herein incorporated by reference in this contract.
- (h) Disputes concerning labor standards. Disputes arising out of the labor standards provisions of this clause shall not be subject to the general disputes clause of this contract. Such disputes shall be resolved in accordance with the procedures of the Department of Labor set forth in 29 CFR Parts 5, 6, and 7. Disputes within the meaning of this clause include disputes between the Contractor (or any of its subcontractors) and the PHA, HUD, the U.S. Department of Labor, or the employees or their representatives.
- (i) Certification of eligibility.
  - (1) By entering into this contract, the Contractor certifies that neither it (nor he or she) nor any person or firm who has an interest in the Contractor's firm is a person or firm ineligible to be awarded contracts by the United States Government by virtue of section 3(a) of the Davis-Bacon Act or 29 CFR 5.12(a)(1).

- (2) No part of this contract shall be subcontracted to any person or firm ineligible for award of a United States Government contract by virtue of section 3(a) of the Davis-Bacon Act or 29 CFR 5.12(a)(1).
  - (3) The penalty for making false statements is prescribed in the U. S. Criminal Code, 18 U.S.C. 1001.
- (j) Contract Work Hours and Safety Standards Act. As used in this paragraph, the terms "laborers" and "mechanics" include watchmen and guards.
- (1) Overtime requirements. No contractor or subcontractor contracting for any part of the contract work which may require or involve the employment of laborers or mechanics, including watchmen and guards, shall require or permit any such laborer or mechanic in any workweek in which the individual is employed on such work to work in excess of 40 hours in such workweek unless such laborer or mechanic receives compensation at a rate not less than one and one-half times the basic rate of pay for all hours worked in excess of 40 hours in such workweek.
  - (2) Violation; liability for unpaid wages; liquidated damages. In the event of any violation of the provisions set forth in subparagraph (j)(1) of this clause, the Contractor and any subcontractor responsible therefor shall be liable for the unpaid wages. In addition, such Contractor and subcontractor shall be liable to the United States (in the case of work done under contract for the District of Columbia or a territory, to such District or to such territory), for liquidated damages. Such liquidated damages shall be computed with respect to each individual laborer or mechanic (including watchmen and guards) employed in violation of the provisions set forth in subparagraph (j)(1) of this clause, in the sum of \$10 for each calendar day on which such individual was required or permitted to work in excess of the standard workweek of 40 hours without payment of the overtime wages required by provisions set forth in subparagraph (j)(1) of this clause.
  - (3) Withholding for unpaid wages and liquidated damages. HUD or its designee shall upon its own action or upon written request of an authorized representative of the Department of Labor withhold or cause to be withheld, from any moneys payable on account of work performed by the Contractor or subcontractor under any such contract or any Federal contract with the same prime Contractor, or any other Federally-assisted contract subject to the Contract Work Hours and Safety Standards Act, which is held by the same prime Contractor, such sums as may be determined to be necessary to satisfy any liabilities of such Contractor or subcontractor for unpaid wages and liquidated damages as provided in the provisions set forth in subparagraph (j)(2) of this clause.
- (k) Subcontracts. The Contractor or subcontractor shall insert in any subcontracts all the provisions contained in this clause, and such other clauses as HUD or its designee may by appropriate instructions require, and also a clause requiring the subcontractors to include these provisions in any lower tier subcontracts. The prime Contractor shall be responsible for the compliance by any subcontractor or lower tier subcontractor with all these provisions.

---

#### 47. Non-Federal Prevailing Wage Rates

- (a) Any prevailing wage rate (including basic hourly rate and any fringe benefits), determined under State or tribal law to be prevailing, with respect to any employee in any trade or position employed under the contract, is inapplicable to the contract and shall not be enforced against the Contractor or any subcontractor, with respect to employees engaged under the contract whenever such non-Federal prevailing wage rate exceeds:
  - (1) The applicable wage rate determined by the Secretary of Labor pursuant to the Davis-Bacon Act (40 U.S.C. 3141 et seq.) to be prevailing in the locality with respect to such trade;
- (b) An applicable apprentice wage rate based thereon specified in an apprenticeship program registered with the U.S. Department of Labor (DOL) or a DOL-recognized State Apprenticeship Agency; or
- (c) An applicable trainee wage rate based thereon specified in a DOL-certified trainee program.

#### 48. Procurement of Recovered Materials.

- (a) In accordance with Section 6002 of the Solid Waste Disposal Act, as amended by the Resource Conservation and Recovery Act, the Contractor shall procure items designated in guidelines of the Environmental Protection Agency (EPA) at 40 CFR Part 247 that contain the highest percentage of recovered materials practicable, consistent with maintaining a satisfactory level of competition. The Contractor shall procure items designated in the EPA guidelines that contain the highest percentage of recovered materials practicable unless the Contractor determines that such items: (1) are not reasonably available in a reasonable period of time; (2) fail to meet reasonable performance standards, which shall be determined on the basis of the guidelines of the National Institute of Standards and Technology, if applicable to the item; or (3) are only available at an unreasonable price.
- (b) Paragraph (a) of this clause shall apply to items purchased under this contract where: (1) the Contractor purchases in excess of \$10,000 of the item under this contract; or (2) during the preceding Federal fiscal year, the Contractor: (i) purchased any amount of the items for use under a contract that was funded with Federal appropriations and was with a Federal agency or a State agency or agency of a political subdivision of a State; and (ii) purchased a total of in excess of \$10,000 of the item both under and outside that contract.



Development & Modernization
100 Ross Street, Suite 200
Pittsburgh, PA 15219
(412) 456-5020
www.hacp.org

SUPPLEMENTAL GENERAL CONDITIONS

SUPPLEMENTAL GENERAL CONDITIONS

To the extent that there is a conflict between the terms of the General Conditions and the terms of the Supplemental General Conditions, the terms of the Supplemental General Conditions shall govern to the extent of such conflict.

If HUD 5370 applies:

Section 31(e) of the General Conditions shall be deleted in its entirety and replaced by the following:

31(e). Forum. The Contracting Officer's decision shall be final unless, within thirty (30) days of receipt of the Contracting Officer's decision, the Contractor files suit in a court of competent jurisdiction.

If HUD 5370-EZ applies:

Section 3(d) of the General Conditions shall be deleted in its entirety and replaced by the following:

31(d). Forum. The Contracting Officer's decision shall be final unless, within thirty (30) days of receipt of the Contracting Officer's decision, the Contractor files suit in a court of competent jurisdiction.

If HUD 5370-C applies:

Section 1 Item 7(d) of the General Conditions shall be deleted in its entirety and replaced by the following:

Section 1 Item 7(d). Forum. The Contracting Officer's decision shall be final unless, within thirty (30) days of receipt of the Contracting Officer's decision, the Contractor files suit in a court of competent jurisdiction.

HOUSING AUTHORITY OF THE CITY OF PITTSBURGH

Date: Signature: Chief Contracting Officer

Vendor Name(Insert vendor company name above)

Date: Signature: Title:

**HOUSING AUTHORITY OF THE CITY OF PITTSBURGH**

**Request for Proposals**

**AUTHORITY WIDE SITE IMPROVEMENTS**

**ATTACHMENT E**

**Instructions to Bidders for Contracts (HUD 5369)**

**U.S. Department of Housing and  
Urban Development**  
Office of Public and Indian Housing

**Instructions to Bidders for Contracts  
Public and Indian Housing Programs**

# Instructions to Bidders for Contracts

## Public and Indian Housing Programs

### Table of Contents

Clause	Page
1. Bid Preparation and Submission	1
2. Explanations and Interpretations to Prospective Bidders	1
3. Amendments to Invitations for Bids	1
4. Responsibility of Prospective Contractor	1
5. Late Submissions, Modifications, and Withdrawal of Bids	1
6. Bid Opening	2
7. Service of Protest	2
8. Contract Award	2
9. Bid Guarantee	3
10. Assurance of Completion	3
11. Preconstruction Conference	3
12. Indian Preference Requirements	3

### 1. Bid Preparation and Submission

(a) Bidders are expected to examine the specifications, drawings, all instructions, and, if applicable, the construction site (see also the contract clause entitled **Site Investigation and Conditions Affecting the Work** of the *General Conditions of the Contract for Construction*). Failure to do so will be at the bidders' risk.

(b) All bids must be submitted on the forms provided by the Public Housing Agency/Indian Housing Authority (PHA/IHA). Bidders shall furnish all the information required by the solicitation. Bids must be signed and the bidder's name typed or printed on the bid sheet and each continuation sheet which requires the entry of information by the bidder. Erasures or other changes must be initialed by the person signing the bid. Bids signed by an agent shall be accompanied by evidence of that agent's authority. (Bidders should retain a copy of their bid for their records.)

(c) Bidders must submit as part of their bid a completed form HUD-5369-A, "Representations, Certifications, and Other Statements of Bidders."

(d) All bid documents shall be sealed in an envelope which shall be clearly marked with the words "Bid Documents," the Invitation for Bids (IFB) number, any project or other identifying number, the bidder's name, and the date and time for receipt of bids.

(e) If this solicitation requires bidding on all items, failure to do so will disqualify the bid. If bidding on all items is not required, bidders should insert the words "No Bid" in the space provided for any item on which no price is submitted.

(f) Unless expressly authorized elsewhere in this solicitation, alternate bids will not be considered.

(g) Unless expressly authorized elsewhere in this solicitation, bids submitted by telegraph or facsimile (fax) machines will not be considered.

(h) If the proposed contract is for a Mutual Help project (as described in 24 CFR Part 905, Subpart E) that involves Mutual Help contributions of work, material, or equipment, supplemental information regarding the bid advertisement is provided as an attachment to this solicitation.

### 2. Explanations and Interpretations to Prospective Bidders

(a) Any prospective bidder desiring an explanation or interpretation of the solicitation, specifications, drawings, etc., must request it at least 7 days before the scheduled time for bid opening. Requests may be oral or written. Oral requests must be confirmed in writing. The only oral clarifications that will be provided will be those clearly related to solicitation procedures, i.e., not substantive technical information. No other oral explanation or interpretation will be provided. Any information given a prospective bidder concerning this solicitation will be furnished promptly to all other prospective bidders as a written amendment to the solicitation, if that information is necessary in submitting bids, or if the lack of it would be prejudicial to other prospective bidders.

(b) Any information obtained by, or provided to, a bidder other than by formal amendment to the solicitation shall not constitute a change to the solicitation.

### 3. Amendments to Invitations for Bids

(a) If this solicitation is amended, then all terms and conditions which are not modified remain unchanged.

(b) Bidders shall acknowledge receipt of any amendment to this solicitation (1) by signing and returning the amendment, (2) by identifying the amendment number and date on the bid form, or (3) by letter, telegram, or facsimile, if those methods are authorized in the solicitation. The PHA/IHA must receive acknowledgement by the time and at the place specified for receipt of bids. Bids which fail to acknowledge the bidder's receipt of any amendment will result in the rejection of the bid if the amendment(s) contained information which substantively changed the PHA's/IHA's requirements.

(c) Amendments will be on file in the offices of the PHA/IHA and the Architect at least 7 days before bid opening.

### 4. Responsibility of Prospective Contractor

(a) The PHA/IHA will award contracts only to responsible prospective contractors who have the ability to perform successfully under the terms and conditions of the proposed contract. In determining the responsibility of a bidder, the PHA/IHA will consider such matters as the bidder's:

- (1) Integrity;
- (2) Compliance with public policy;
- (3) Record of past performance; and
- (4) Financial and technical resources (including construction and technical equipment).

(b) Before a bid is considered for award, the bidder may be requested by the PHA/IHA to submit a statement or other documentation regarding any of the items in paragraph (a) above. Failure by the bidder to provide such additional information shall render the bidder nonresponsible and ineligible for award.

## 5. Late Submissions, Modifications, and Withdrawal of Bids

(a) Any bid received at the place designated in the solicitation after the exact time specified for receipt will not be considered unless it is received before award is made and it:

(1) Was sent by registered or certified mail not later than the fifth calendar day before the date specified for receipt of offers (e.g., an offer submitted in response to a solicitation requiring receipt of offers by the 20th of the month must have been mailed by the 15th);

(2) Was sent by mail, or if authorized by the solicitation, was sent by telegram or via facsimile, and it is determined by the PHA/IHA that the late receipt was due solely to mishandling by the PHA/IHA after receipt at the PHA/IHA; or

(3) Was sent by U.S. Postal Service Express Mail Next Day Service - Post Office to Addressee, not later than 5:00 p.m. at the place of mailing two working days prior to the date specified for receipt of proposals. The term "working days" excludes weekends and observed holidays.

(b) Any modification or withdrawal of a bid is subject to the same conditions as in paragraph (a) of this provision.

(c) The only acceptable evidence to establish the date of mailing of a late bid, modification, or withdrawal sent either by registered or certified mail is the U.S. or Canadian Postal Service postmark both on the envelope or wrapper and on the original receipt from the U.S. or Canadian Postal Service. Both postmarks must show a legible date or the bid, modification, or withdrawal shall be processed as if mailed late. "Postmark" means a printed, stamped, or otherwise placed impression (exclusive of a postage meter machine impression) that is readily identifiable without further action as having been supplied and affixed by employees of the U.S. or Canadian Postal Service on the date of mailing. Therefore, bidders should request the postal clerk to place a hand cancellation bull's-eye postmark on both the receipt and the envelope or wrapper.

(d) The only acceptable evidence to establish the time of receipt at the PHA/IHA is the time/date stamp of PHA/IHA on the proposal wrapper or other documentary evidence of receipt maintained by the PHA/IHA.

(e) The only acceptable evidence to establish the date of mailing of a late bid, modification, or withdrawal sent by Express Mail Next Day Service-Post Office to Addressee is the date entered by the post office receiving clerk on the "Express Mail Next Day Service-Post Office to Addressee" label and the postmark on both the envelope or wrapper and on the original receipt from the U.S. Postal Service. "Postmark" has the same meaning as defined in paragraph (c) of this provision, excluding postmarks of the Canadian Postal Service. Therefore, bidders should request the postal clerk to place a legible hand cancellation bull's eye postmark on both the receipt and Failure by a bidder to acknowledge receipt of the envelope or wrapper.

(f) Notwithstanding paragraph (a) of this provision, a late modification of an otherwise successful bid that makes its terms more favorable to the PHA/IHA will be considered at any time it is received and may be accepted.

(g) Bids may be withdrawn by written notice, or if authorized by this solicitation, by telegram (including mailgram) or facsimile machine transmission received at any time before the exact time set for opening of bids; provided that written confirmation of telegraphic or facsimile withdrawals over the signature of the bidder is mailed and postmarked prior to the specified bid opening time. A bid may be withdrawn in person by a bidder or its authorized representative if, before the exact time set for opening of bids, the identity of the person requesting withdrawal is established and the person signs a receipt for the bid.

## 6. Bid Opening

All bids received by the date and time of receipt specified in the solicitation will be publicly opened and read. The time and place of opening will be as specified in the solicitation. Bidders and other interested persons may be present.

## 7. Service of Protest

(a) Definitions. As used in this provision:

"Interested party" means an actual or prospective bidder whose direct economic interest would be affected by the award of the contract.

"Protest" means a written objection by an interested party to this solicitation or to a proposed or actual award of a contract pursuant to this solicitation.

(b) Protests shall be served on the Contracting Officer by obtaining written and dated acknowledgement from —

Contracting Officer  
Legal Department  
Housing Authority of the City of Pittsburgh  
200 Ross Street, 7th Floor  
Pittsburgh, PA 15219

[Contracting Officer designate the official or location where a protest may be served on the Contracting Officer]

(c) All protests shall be resolved in accordance with the PHA's/IHA's protest policy and procedures, copies of which are maintained at the PHA/IHA.

## 8. Contract Award

(a) The PHA/IHA will evaluate bids in response to this solicitation without discussions and will award a contract to the responsible bidder whose bid, conforming to the solicitation, will be most advantageous to the PHA/IHA considering only price and any price-related factors specified in the solicitation.

(b) If the apparent low bid received in response to this solicitation exceeds the PHA's/IHA's available funding for the proposed contract work, the PHA/IHA may either accept separately priced items (see 8(e) below) or use the following procedure to determine contract award. The PHA/IHA shall apply in turn to each bid (proceeding in order from the apparent low bid to the high bid) each of the separately priced bid deductible items, if any, in their priority order set forth in this solicitation. If upon the application of the first deductible item to all initial bids, a new low bid is within the PHA's/IHA's available funding, then award shall be made to that bidder. If no bid is within the available funding amount, then the PHA/IHA shall apply the second deductible item. The PHA/IHA shall continue this process until an evaluated low bid, if any, is within the PHA's/IHA's available funding. If upon the application of all deductibles, no bid is within the PHA's/IHA's available funding, or if the solicitation does not request separately priced deductibles, the PHA/IHA shall follow its written policy and procedures in making any award under this solicitation.

(c) In the case of tie low bids, award shall be made in accordance with the PHA's/IHA's written policy and procedures.

(d) The PHA/IHA may reject any and all bids, accept other than the lowest bid (e.g., the apparent low bid is unreasonably low), and waive informalities or minor irregularities in bids received, in accordance with the PHA's/IHA's written policy and procedures.

(e) Unless precluded elsewhere in the solicitation, the PHA/IHA may accept any item or combination of items bid.

(f) The PHA/IHA may reject any bid as nonresponsive if it is materially unbalanced as to the prices for the various items of work to be performed. A bid is materially unbalanced when it is based on prices significantly less than cost for some work and prices which are significantly overstated for other work.

(g) A written award shall be furnished to the successful bidder within the period for acceptance specified in the bid and shall result in a binding contract without further action by either party.

**9. Bid Guarantee (applicable to construction and equipment contracts exceeding \$25,000)**

All bids must be accompanied by a negotiable bid guarantee which shall not be less than five percent (5%) of the amount of the bid. The bid guarantee may be a certified check, bank draft, U.S. Government Bonds at par value, or a bid bond secured by a surety company acceptable to the U.S. Government and authorized to do business in the state where the work is to be performed. In the case where the work under the contract will be performed on an Indian reservation area, the bid guarantee may also be an irrevocable Letter of Credit (see provision 10, Assurance of Completion, below). Certified checks and bank drafts must be made payable to the order of the PHA/IHA. The bid guarantee shall insure the execution of the contract and the furnishing of a method of assurance of completion by the successful bidder as required by the solicitation. Failure to submit a bid guarantee with the bid shall result in the rejection of the bid. Bid guarantees submitted by unsuccessful bidders will be returned as soon as practicable after bid opening.

**10. Assurance of Completion**

(a) Unless otherwise provided in State law, the successful bidder shall furnish an assurance of completion prior to the execution of any contract under this solicitation. This assurance may be [Contracting Officer check applicable items] —

(1) a performance and payment bond in a penal sum of 100 percent of the contract price; or, as may be required or permitted by State law;

(2) separate performance and payment bonds, each for 50 percent or more of the contract price;

(3) a 20 percent cash escrow;

(4) a 25 percent irrevocable letter of credit; or,

(5) an irrevocable letter of credit for 10 percent of the total contract price with a monitoring and disbursements agreement with the IHA (applicable only to contracts awarded by an IHA under the Indian Housing Program).

(b) Bonds must be obtained from guarantee or surety companies acceptable to the U.S. Government and authorized to do business in the state where the work is to be performed. Individual sureties will not be considered. U.S. Treasury Circular Number 570, published annually in the Federal Register, lists companies approved to act as sureties on bonds securing Government contracts, the maximum underwriting limits on each contract bonded, and the States in which the company is licensed to do business. Use of companies listed in this circular is mandatory. Copies of the circular may be downloaded on the U.S. Department of Treasury website <http://www.fms.treas.gov/c570/index.html>, or ordered for a minimum fee by contacting the Government Printing Office at (202) 512-2168.

(c) Each bond shall clearly state the rate of premium and the total amount of premium charged. The current power of attorney for the person who signs for the surety company must be attached to the bond. The effective date of the power of attorney shall not precede the date of the bond. The effective date of the bond shall be on or after the execution date of the contract.

(d) Failure by the successful bidder to obtain the required assurance of completion within the time specified, or within such extended period as the PHA/IHA may grant based upon reasons determined adequate by the PHA/IHA, shall render the bidder ineligible for award. The PHA/IHA may then either award the contract to the next lowest responsible bidder or solicit new bids. The PHA/IHA may retain the ineligible bidder's bid guarantee.

**11. Preconstruction Conference (applicable to construction contracts)**

After award of a contract under this solicitation and prior to the start of work, the successful bidder will be required to attend a preconstruction conference with representatives of the PHA/IHA and its architect/engineer, and other interested parties convened by the PHA/IHA. The conference will serve to acquaint the participants with the general plan of the construction operation and all other requirements of the contract (e.g., Equal Employment Opportunity, Labor Standards). The PHA/IHA will provide the successful bidder with the date, time, and place of the conference.

**12. Indian Preference Requirements (applicable only if this solicitation is for a contract to be performed on a project for an Indian Housing Authority)**

(a) HUD has determined that the contract awarded under this solicitation is subject to the requirements of section 7(b) of the Indian Self-Determination and Education Assistance Act (25 U.S.C. 450e(b)). Section 7(b) requires that any contract or subcontract entered into for the benefit of Indians shall require that, to the greatest extent feasible

(1) Preferences and opportunities for training and employment (other than core crew positions; see paragraph (h) below) in connection with the administration of such contracts or subcontracts be given to qualified "Indians." The Act defines "Indians" to mean persons who are members of an Indian tribe and defines "Indian tribe" to mean any Indian tribe, band, nation, or other organized group or community, including any Alaska Native village or regional or village corporation as defined in or established pursuant to the Alaska Native Claims Settlement Act, which is recognized as eligible for the special programs and services provided by the United States to Indians because of their status as Indians; and,

(2) Preference in the award of contracts or subcontracts in connection with the administration of contracts be given to Indian organizations and to Indian-owned economic enterprises, as defined in section 3 of the Indian Financing Act of 1974 (25 U.S.C. 1452). That Act defines "economic enterprise" to mean any Indian-owned commercial, industrial, or business activity established or organized for the purpose of profit, except that the Indian ownership must constitute not less than 51 percent of the enterprise; "Indian organization" to mean the governing body of any Indian tribe or entity established or recognized by such governing body; "Indian" to mean any person who is a member of any tribe, band, group, pueblo, or community which is recognized by the Federal Government as eligible for services from the Bureau of Indian Affairs and any "Native" as defined in the Alaska Native Claims Settlement Act; and Indian "tribe" to mean any Indian tribe, band, group, pueblo, or community including Native villages and Native groups (including



corporations organized by Kenai, Juneau, Sitka, and Kodiak) as defined in the Alaska Native Claims Settlement Act, which is recognized by the Federal Government as eligible for services from the Bureau of Indian Affairs.

(b) (1) The successful Contractor under this solicitation shall comply with the requirements of this provision in awarding all subcontracts under the contract and in providing training and employment opportunities.

(2) A finding by the IHA that the contractor, either (i) awarded a subcontract without using the procedure required by the IHA, (ii) falsely represented that subcontracts would be awarded to Indian enterprises or organizations; or, (iii) failed to comply with the contractor's employment and training preference bid statement shall be grounds for termination of the contract or for the assessment of penalties or other remedies.

(c) If specified elsewhere in this solicitation, the IHA may restrict the solicitation to qualified Indian-owned enterprises and Indian organizations. If two or more (or a greater number as specified elsewhere in the solicitation) qualified Indian-owned enterprises or organizations submit responsive bids, award shall be made to the qualified enterprise or organization with the lowest responsive bid. If fewer than the minimum required number of qualified Indian-owned enterprises or organizations submit responsive bids, the IHA shall reject all bids and readvertise the solicitation in accordance with paragraph (d) below.

(d) If the IHA prefers not to restrict the solicitation as described in paragraph (c) above, or if after having restricted a solicitation an insufficient number of qualified Indian enterprises or organizations submit bids, the IHA may advertise for bids from non-Indian as well as Indian-owned enterprises and Indian organizations. Award shall be made to the qualified Indian enterprise or organization with the lowest responsive bid if that bid is -

(1) Within the maximum HUD-approved budget amount established for the specific project or activity for which bids are being solicited; and

(2) No more than the percentage specified in 24 CFR 905.175(c) higher than the total bid price of the lowest responsive bid from any qualified bidder. If no responsive bid by a qualified Indian-owned economic enterprise or organization is within the stated range of the total bid price of the lowest responsive bid from any qualified enterprise, award shall be made to the bidder with the lowest bid.

(e) Bidders seeking to qualify for preference in contracting or subcontracting shall submit proof of Indian ownership with their bids. Proof of Indian ownership shall include but not be limited to:

(1) Certification by a tribe or other evidence that the bidder is an Indian. The IHA shall accept the certification of a tribe that an individual is a member.

(2) Evidence such as stock ownership, structure, management, control, financing and salary or profit sharing arrangements of the enterprise.

(f) (1) All bidders must submit with their bids a statement describing how they will provide Indian preference in the award of subcontracts. The specific requirements of that statement and the factors to be used by the IHA in determining the statement's adequacy are included as an attachment to this solicitation. Any bid that fails to include the required statement shall be rejected as nonresponsive. The IHA may require that comparable statements be provided by subcontractors to the successful Contractor, and may require the Contractor to reject any bid or proposal by a subcontractor that fails to include the statement.

(2) Bidders and prospective subcontractors shall submit a certification (supported by credible evidence) to the IHA in any instance where the bidder or subcontractor believes it is infeasible to provide Indian preference in subcontracting. The acceptance or rejection by the IHA of the certification shall be final. Rejection shall disqualify the bid from further consideration.

(g) All bidders must submit with their bids a statement detailing their employment and training opportunities and their plans to provide preference to Indians in implementing the contract; and the number or percentage of Indians anticipated to be employed and trained. Comparable statements from all proposed subcontractors must be submitted. The criteria to be used by the IHA in determining the statement(s)'s adequacy are included as an attachment to this solicitation. Any bid that fails to include the required statement(s), or that includes a statement that does not meet minimum standards required by the IHA shall be rejected as nonresponsive.

(h) Core crew employees. A core crew employee is an individual who is a bona fide employee of the contractor at the time the bid is submitted; or an individual who was not employed by the bidder at the time the bid was submitted, but who is regularly employed by the bidder in a supervisory or other key skilled position when work is available. Bidders shall submit with their bids a list of all core crew employees.

(i) Preference in contracting, subcontracting, employment, and training shall apply not only on-site, on the reservation, or within the IHA's jurisdiction, but also to contracts with firms that operate outside these areas (e.g., employment in modular or manufactured housing construction facilities).

(j) Bidders should contact the IHA to determine if any additional local preference requirements are applicable to this solicitation.

(k) The IHA [ ] does [X] does not [Contracting Officer check applicable box] maintain lists of Indian-owned economic enterprises and Indian organizations by specialty (e.g., plumbing, electrical, foundations), which are available to bidders to assist them in meeting their responsibility to provide preference in connection with the administration of contracts and subcontracts.

**HOUSING AUTHORITY OF THE CITY OF PITTSBURGH**

**Request for Proposals**

**AUTHORITY WIDE SITE IMPROVEMENTS**

**ATTACHMENT F**

**Representations, Certifications, and Other Statements of Bidders  
(HUD 5369A)**

**U.S. Department of Housing  
and Urban Development**  
Office of Public and Indian Housing

**Representations, Certifications,  
and Other Statements of Bidders**  
**Public and Indian Housing Programs**

# Representations, Certifications, and Other Statements of Bidders

## Public and Indian Housing Programs

### Table of Contents

Clause	Page
1. Certificate of Independent Price Determination	1
2. Contingent Fee Representation and Agreement	1
3. Certification and Disclosure Regarding Payments to Influence Certain Federal Transactions	1
4. Organizational Conflicts of Interest Certification	2
5. Bidder's Certification of Eligibility	2
6. Minimum Bid Acceptance Period	2
7. Small, Minority, Women-Owned Business Concern Representation	2
8. Indian-Owned Economic Enterprise and Indian Organization Representation	2
9. Certification of Eligibility Under the Davis-Bacon Act	3
10. Certification of Nonsegregated Facilities	3
11. Clean Air and Water Certification	3
12. Previous Participation Certificate	3
13. Bidder's Signature	3

### 1. Certificate of Independent Price Determination

#### (a) The bidder certifies that--

(1) The prices in this bid have been arrived at independently, without, for the purpose of restricting competition, any consultation, communication, or agreement with any other bidder or competitor relating to (i) those prices, (ii) the intention to submit a bid, or (iii) the methods or factors used to calculate the prices offered;

(2) The prices in this bid have not been and will not be knowingly disclosed by the bidder, directly or indirectly, to any other bidder or competitor before bid opening (in the case of a sealed bid solicitation) or contract award (in the case of a competitive proposal solicitation) unless otherwise required by law; and

(3) No attempt has been made or will be made by the bidder to induce any other concern to submit or not to submit a bid for the purpose of restricting competition.

(b) Each signature on the bid is considered to be a certification by the signatory that the signatory--

(1) Is the person in the bidder's organization responsible for determining the prices being offered in this bid or proposal, and that the signatory has not participated and will not participate in any action contrary to subparagraphs (a)(1) through (a)(3) above; or

(2) (i) Has been authorized, in writing, to act as agent for the following principals in certifying that those principals have not participated, and will not participate in any action contrary to subparagraphs (a)(1) through (a)(3) above.

\_\_\_\_\_ [insert full name of person(s) in the bidder's organization responsible for determining the prices offered in this bid or proposal, and the title of his or her position in the bidder's organization];

(ii) As an authorized agent, does certify that the principals named in subdivision (b)(2)(i) above have not participated, and will not participate, in any action contrary to subparagraphs (a)(1) through (a)(3) above; and

(iii) As an agent, has not personally participated, and will not participate in any action contrary to subparagraphs (a)(1) through (a)(3) above.

(c) If the bidder deletes or modifies subparagraph (a)(2) above, the bidder must furnish with its bid a signed statement setting forth in detail the circumstances of the disclosure.

[Contracting Officer check if following paragraph is applicable]

(d) Non-collusive affidavit. (applicable to contracts for construction and equipment exceeding \$50,000)

(1) Each bidder shall execute, in the form provided by the PHA/IHA, an affidavit to the effect that he/she has not colluded with any other person, firm or corporation in regard to any bid submitted in response to this solicitation. If the successful bidder did not submit the affidavit with his/her bid, he/she must submit it within three (3) working days of bid opening. Failure to submit the affidavit by that date may render the bid nonresponsive. No contract award will be made without a properly executed affidavit.

(2) A fully executed "Non-collusive Affidavit"  is,  is not included with the bid.

### 2. Contingent Fee Representation and Agreement

(a) Definitions. As used in this provision:

"Bona fide employee" means a person, employed by a bidder and subject to the bidder's supervision and control as to time, place, and manner of performance, who neither exerts, nor proposes to exert improper influence to solicit or obtain contracts nor holds out as being able to obtain any contract(s) through improper influence.

"Improper influence" means any influence that induces or tends to induce a PHA/IHA employee or officer to give consideration or to act regarding a PHA/IHA contract on any basis other than the merits of the matter.

(b) The bidder represents and certifies as part of its bid that, except for full-time bona fide employees working solely for the bidder, the bidder:

(1)  has,  has not employed or retained any person or company to solicit or obtain this contract; and

(2)  has,  has not paid or agreed to pay to any person or company employed or retained to solicit or obtain this contract any commission, percentage, brokerage, or other fee contingent upon or resulting from the award of this contract.

(c) If the answer to either (a)(1) or (a)(2) above is affirmative, the bidder shall make an immediate and full written disclosure to the PHA/IHA Contracting Officer.

(d) Any misrepresentation by the bidder shall give the PHA/IHA the right to (1) terminate the contract; (2) at its discretion, deduct from contract payments the amount of any commission, percentage, brokerage, or other contingent fee; or (3) take other remedy pursuant to the contract.

### 3. Certification and Disclosure Regarding Payments to Influence Certain Federal Transactions (applicable to contracts exceeding \$100,000)

(a) The definitions and prohibitions contained in Section 1352 of title 31, United States Code, are hereby incorporated by reference in paragraph (b) of this certification.

(b) The bidder, by signing its bid, hereby certifies to the best of his or her knowledge and belief as of December 23, 1989 that:

(1) No Federal appropriated funds have been paid or will be paid to any person for influencing or attempting to influence an officer or employee of any agency, a Member of Congress, an officer or employee of Congress, or an employee of a Member of Congress on his or her behalf in connection with the awarding of a contract resulting from this solicitation;

(2) If any funds other than Federal appropriated funds (including profit or fee received under a covered Federal transaction) have been paid, or will be paid, to any person for influencing or attempting to influence an officer or employee of any agency, a Member of Congress, an officer or employee of Congress, or an employee of a Member of Congress on his or her behalf in connection with this solicitation, the bidder shall complete and submit, with its bid, OMB standard form LLL, "Disclosure of Lobbying Activities;" and

(3) He or she will include the language of this certification in all subcontracts at any tier and require that all recipients of subcontract awards in excess of \$100,000 shall certify and disclose accordingly.

(c) Submission of this certification and disclosure is a prerequisite for making or entering into this contract imposed by section 1352, title 31, United States Code. Any person who makes an expenditure prohibited under this provision or who fails to file or amend the disclosure form to be filed or amended by this provision, shall be subject to a civil penalty of not less than \$10,000, and not more than \$100,000, for each such failure.

(d) Indian tribes (except those chartered by States) and Indian organizations as defined in section 4 of the Indian Self-Determination and Education Assistance Act (25 U.S.C. 450B) are exempt from the requirements of this provision.

#### 4. Organizational Conflicts of Interest Certification

The bidder certifies that to the best of its knowledge and belief and except as otherwise disclosed, he or she does not have any organizational conflict of interest which is defined as a situation in which the nature of work to be performed under this proposed contract and the bidder's organizational, financial, contractual, or other interests may, without some restriction on future activities:

- (a) Result in an unfair competitive advantage to the bidder; or,
- (b) Impair the bidder's objectivity in performing the contract work.

[ ] In the absence of any actual or apparent conflict, I hereby certify that to the best of my knowledge and belief, no actual or apparent conflict of interest exists with regard to my possible performance of this procurement.

#### 5. Bidder's Certification of Eligibility

(a) By the submission of this bid, the bidder certifies that to the best of its knowledge and belief, neither it, nor any person or firm which has an interest in the bidder's firm, nor any of the bidder's subcontractors, is ineligible to:

(1) Be awarded contracts by any agency of the United States Government, HUD, or the State in which this contract is to be performed; or,

(2) Participate in HUD programs pursuant to 24 CFR Part 24.

(b) The certification in paragraph (a) above is a material representation of fact upon which reliance was placed when making award. If it is later determined that the bidder knowingly rendered an erroneous certification, the contract may be terminated for default, and the bidder may be debarred or suspended from participation in HUD programs and other Federal contract programs.

#### 6. Minimum Bid Acceptance Period

(a) "Acceptance period," as used in this provision, means the number of calendar days available to the PHA/IHA for awarding a contract from the date specified in this solicitation for receipt of bids.

(b) This provision supersedes any language pertaining to the acceptance period that may appear elsewhere in this solicitation.

(c) The PHA/IHA requires a minimum acceptance period of [Contracting Officer insert time period] calendar days.

(d) In the space provided immediately below, bidders may specify a longer acceptance period than the PHA's/IHA's minimum requirement. The bidder allows the following acceptance period: calendar days.

(e) A bid allowing less than the PHA's/IHA's minimum acceptance period will be rejected.

(f) The bidder agrees to execute all that it has undertaken to do, in compliance with its bid, if that bid is accepted in writing within (1) the acceptance period stated in paragraph (c) above or (2) any longer acceptance period stated in paragraph (d) above.

#### 7. Small, Minority, Women-Owned Business Concern Representation

The bidder represents and certifies as part of its bid/ offer that it --

(a) [ ] is, [ ] is not a small business concern. "Small business concern," as used in this provision, means a concern, including its affiliates, that is independently owned and operated, not dominant in the field of operation in which it is bidding, and qualified as a small business under the criteria and size standards in 13 CFR 121.

(b) [ ] is, [ ] is not a women-owned business enterprise. "Women-owned business enterprise," as used in this provision, means a business that is at least 51 percent owned by a woman or women who are U.S. citizens and who also control and operate the business.

(c) [ ] is, [ ] is not a minority business enterprise. "Minority business enterprise," as used in this provision, means a business which is at least 51 percent owned or controlled by one or more minority group members or, in the case of a publicly owned business, at least 51 percent of its voting stock is owned by one or more minority group members, and whose management and daily operations are controlled by one or more such individuals. For the purpose of this definition, minority group members are:

(Check the block applicable to you)

- [ ] Black Americans
- [ ] Asian Pacific Americans
- [ ] Hispanic Americans
- [ ] Asian Indian Americans
- [ ] Native Americans
- [ ] Hasidic Jewish Americans

#### 8. Indian-Owned Economic Enterprise and Indian Organization Representation (applicable only if this solicitation is for a contract to be performed on a project for an Indian Housing Authority)

The bidder represents and certifies that it:

(a) [ ] is, [ ] is not an Indian-owned economic enterprise. "Economic enterprise," as used in this provision, means any commercial, industrial, or business activity established or organized for the purpose of profit, which is at least 51 percent Indian owned. "Indian," as used in this provision, means any person who is a member of any tribe, band, group, pueblo, or community which is recognized by the Federal Government as eligible for services from the Bureau of Indian Affairs and any "Native" as defined in the Alaska Native Claims Settlement Act.

(b) [ ] is, [ ] is not an Indian organization. "Indian organization," as used in this provision, means the governing body of any Indian tribe or entity established or recognized by such governing body. Indian "tribe" means any Indian tribe, band, group, pueblo, or

community including Native villages and Native groups (including corporations organized by Kenai, Juneau, Sitka, and Kodiak) as defined in the Alaska Native Claims Settlement Act, which is recognized by the Federal Government as eligible for services from the Bureau of Indian Affairs.

**9. Certification of Eligibility Under the Davis-Bacon Act** (applicable to construction contracts exceeding \$2,000)

(a) By the submission of this bid, the bidder certifies that neither it nor any person or firm who has an interest in the bidder's firm is a person or firm ineligible to be awarded contracts by the United States Government by virtue of section 3(a) of the Davis-Bacon Act or 29 CFR 5.12(a)(1).

(b) No part of the contract resulting from this solicitation shall be subcontracted to any person or firm ineligible to be awarded contracts by the United States Government by virtue of section 3(a) of the Davis-Bacon Act or 29 CFR 5.12(a)(1).

(c) The penalty for making false statements is prescribed in the U. S. Criminal Code, 18 U.S.C. 1001.

**10. Certification of Nonsegregated Facilities** (applicable to contracts exceeding \$10,000)

(a) The bidder's attention is called to the clause entitled **Equal Employment Opportunity** of the General Conditions of the Contract for Construction.

(b) "Segregated facilities," as used in this provision, means any waiting rooms, work areas, rest rooms and wash rooms, restaurants and other eating areas, time clocks, locker rooms and other storage or dressing areas, parking lots, drinking fountains, recreation or entertainment areas, transportation, and housing facilities provided for employees, that are segregated by explicit directive or are in fact segregated on the basis of race, color, religion, or national origin because of habit, local custom, or otherwise.

(c) By the submission of this bid, the bidder certifies that it does not and will not maintain or provide for its employees any segregated facilities at any of its establishments, and that it does not and will not permit its employees to perform their services at any location under its control where segregated facilities are maintained. The bidder agrees that a breach of this certification is a violation of the Equal Employment Opportunity clause in the contract.

(d) The bidder further agrees that (except where it has obtained identical certifications from proposed subcontractors for specific time periods) prior to entering into subcontracts which exceed \$10,000 and are not exempt from the requirements of the Equal Employment Opportunity clause, it will:

- (1) Obtain identical certifications from the proposed subcontractors;
- (2) Retain the certifications in its files; and
- (3) Forward the following notice to the proposed subcontractors (except if the proposed subcontractors have submitted identical certifications for specific time periods):

**Notice to Prospective Subcontractors of Requirement for Certifications of Nonsegregated Facilities**

A Certification of Nonsegregated Facilities must be submitted before the award of a subcontract exceeding \$10,000 which is not exempt from the provisions of the Equal Employment Opportunity clause of the prime contract. The certification may be submitted either for each subcontract or for all subcontracts during a period (i.e., quarterly, semiannually, or annually).

**Note:** The penalty for making false statements in bids is prescribed in 18 U.S.C. 1001.

**11. Clean Air and Water Certification** (applicable to contracts exceeding \$100,000)

The bidder certifies that:

(a) Any facility to be used in the performance of this contract [ ] is, [ ] is not listed on the Environmental Protection Agency List of Violating Facilities:

(b) The bidder will immediately notify the PHA/IHA Contracting Officer, before award, of the receipt of any communication from the Administrator, or a designee, of the Environmental Protection Agency, indicating that any facility that the bidder proposes to use for the performance of the contract is under consideration to be listed on the EPA List of Violating Facilities; and,

(c) The bidder will include a certification substantially the same as this certification, including this paragraph (c), in every nonexempt subcontract.

**12. Previous Participation Certificate** (applicable to construction and equipment contracts exceeding \$50,000)

(a) The bidder shall complete and submit with his/her bid the Form HUD-2530, "Previous Participation Certificate." If the successful bidder does not submit the certificate with his/her bid, he/she must submit it within three (3) working days of bid opening. Failure to submit the certificate by that date may render the bid nonresponsive. No contract award will be made without a properly executed certificate.

(b) A fully executed "Previous Participation Certificate" [ ] is, [ ] is not included with the bid.

**13. Bidder's Signature**

The bidder hereby certifies that the information contained in these certifications and representations is accurate, complete, and current.

\_\_\_\_\_  
(Signature and Date)

\_\_\_\_\_  
(Typed or Printed Name)

\_\_\_\_\_  
(Title)

\_\_\_\_\_  
(Company Name)

\_\_\_\_\_  
(Company Address)

**HOUSING AUTHORITY OF THE CITY OF PITTSBURGH**

**Request for Proposals**

**AUTHORITY WIDE SITE IMPROVEMENTS**

**ATTACHMENT G**

**MBE WBE Special Participation Summary**

HOUSING AUTHORITY OF THE CITY OF PITTSBURGH  
 MBE/WBE SOLICITATION AND COMMITMENT RECORD

<b>SOLICITATION AND COMMITMENT STATEMENT</b>					
<b>MINORITY (MBE) AND FEMALE (WBE) OWNED BUSINESS ENTERPRISES</b>					
BID NUMBER	NAME OF BIDDER	ADDRESS		PHONE	
List below All MBE/WBE's that were solicited - whether or not a commitment was obtained -- Copy this form as necessary					
____ MBE      ____ WBE	TYPE OF SUBCONTRACT WORK OR MATERIALS	<u>DATE SOLICITED</u> BY PHONE    BY MAIL		<u>COMMITMENT MADE</u> <b>YES</b> <b>NO</b> <small>(IF YES, GIVE DATE)</small>	GIVE REASON(S) IF NO COMMITMENT MADE
COMPANY NAME		QUOTE RECEIVED		AMOUNT COMMITTED	
ADDRESS		YES	NO	DOLLAR AMOUNT \$	
CONTACT PERSON PHONE				PERCENT OF TOTAL BID %	
____ MBE      ____ WBE	TYPE OF SUBCONTRACT WORK OR MATERIALS	<u>DATE SOLICITED</u> BY PHONE    BY MAIL		<u>COMMITMENT MADE</u> <b>YES</b> <b>NO</b> <small>(IF YES, GIVE DATE)</small>	GIVE REASON(S) IF NO COMMITMENT MADE
COMPANY NAME		QUOTE RECEIVED		AMOUNT COMMITTED	
ADDRESS		YES	NO	DOLLAR AMOUNT \$	
CONTACT PERSON PHONE				PERCENT OF TOTAL BID %	
____ MBE      ____ WBE	TYPE OF SUBCONTRACT WORK OR MATERIALS	<u>DATE SOLICITED</u> BY PHONE    BY MAIL		<u>COMMITMENT MADE</u> <b>YES</b> <b>NO</b> <small>(IF YES, GIVE DATE)</small>	GIVE REASON(S) IF NO COMMITMENT MADE
COMPANY NAME		QUOTE RECEIVED		AMOUNT COMMITTED	
ADDRESS		YES	NO	DOLLAR AMOUNT \$	
CONTACT PERSON PHONE				PERCENT OF TOTAL BID %	

Prepared by:

Title:

Phone:

NOTE: Certification and letters of intent for each MBE/WBE commitment must accompany this document.



## MBE/WBE Participation Plan

### I. SMALL BUSINESS PARTICIPATION

Is the Bidder a Small Business as defined by the size and standards in 13 CFR 121?

Yes \_\_\_\_\_ No \_\_\_\_\_

### II. MINORITY BUSINESS PARTICIPATION

Is the Bidder classified as a Minority Business Enterprise?

Yes \_\_\_\_\_ No \_\_\_\_\_

If “No”, are any Subcontractors classified as Minority Business enterprises?

Yes \_\_\_\_\_ No \_\_\_\_\_

If “Yes”, please fill in the following chart:

Consulting Firm(s) (MBE)	\$ Value Contract	% of Fee

### III. WOMEN-OWNED BUSINESS PARTICIPATION

Is the Bidder classified as a Woman-Owned Business Enterprise?

Yes \_\_\_\_\_ No \_\_\_\_\_

If “No”, are any Subcontractors classified as Women-Owned Business Enterprises?

Yes \_\_\_\_\_ No \_\_\_\_\_

If “Yes”, please fill in the following chart:

Consulting Firm(s) (WBE)	\$ Value Contract	% of Fee

**\*\*All MBE/WBE firms must be certified.**

**In order for the MBE/WBE participation plan to be complete, copies of MBE/WBE certification must be included for all firms listed.**



HOUSING AUTHORITY OF THE CITY OF PITTSBURGH  
MBE/WBE SOLICITATION AND COMMITMENT STATEMENT  
**ADDITIONAL INFORMATION SHEET**

The bidder presents the following as additional and supplemental information to its MBE/WBE Solicitation and Commitment Statement.

Prepared by:

Title:

Phone:

HOUSING AUTHORITY OF THE CITY OF PITTSBURGH  
MBE/WBE EXHIBIT

**MBE/WBE COMMITMENT WAIVER REQUEST FORM**

BIDDER'S FIRM: \_\_\_\_\_  
ADDRESS: \_\_\_\_\_  
TELEPHONE: \_\_\_\_\_  
CONTACT PERSON: \_\_\_\_\_  
PROPOSAL AND BID FOR: \_\_\_\_\_

---

Waiver of the MBE/WBE participation requirement is requested for the following reasons:

Prepared by: \_\_\_\_\_ Title: \_\_\_\_\_ Phone: \_\_\_\_\_

NOTE: The fully completed MBE/WBE Solicitation and Commitment Statement must accompany this waiver request.

**Notice of Requirement for Affirmative Action  
to Ensure Equal Employment Opportunity  
(Executive Order 11625)**

1. The Offeror's or Bidder's attention is called to the "Equal Opportunity Clause" and the "Standard Federal Equal Employment Specifications" set forth herein.
2. The goals for minority and female participation at the Housing Authority of the City of Pittsburgh are pursuant to the Mayor's promulgated Executive Order, and the action of the Housing Authority Board. Expressed in percentage terms for the Contractor's aggregate workforce in each trade on all construction work in the covered area, these goals are eighteen percent (18%) of the total cost of the contract to be expended for minority participation and seven percent (7%) for women participation. These goals are applicable to all the Contractor's construction work (whether or not it is Federal or federally assisted) performed in the covered area. If the contractor performs construction work in a geographical area located outside of the covered area, it shall apply the goals established for such geographical area where the work is actually performed. With regard to this second area, the contractor also is subject to the goals for both its federally involved and nonfederally involved construction.

The Contractor's compliance with the Executive Order and the regulations in Section 41 CFR Part 60-4 shall be based on its implementation of the Equal Opportunity Clause, specific affirmative action obligations required by the specifications set forth in Section 41 CFR Part 60-4.3(a), and its efforts to meet the goals. The hours of minority and female employment and training must be substantially uniform throughout the length of the contract, and in each trade, and the contractor shall make a good faith effort to employ minorities and women evenly on each of its projects. The transfer of minority or female employees or trainees from Contractor to Contractor or from project to project for the sole purpose of meeting the Contractor's goals shall be a violation of the contract, the Executive Order and the regulations in Section 41 CFR Part 60-4. Compliance with the goals will be measured against the total work hours performed.

3. The Contractor shall provide written notification, within 10 working days of award of any construction subcontract in excess of \$10,000 at any tier for construction work under the contract resulting from this solicitation, to:

LaVaris Ross, Labor Relations Specialist  
U.S. Department of Housing and Urban Development  
Office of Labor Relations  
City Crescent Building  
10 S. Howard Street, 5<sup>th</sup> Floor  
Baltimore, MD 21201

The notification shall list the name, address and telephone number of the subcontractor; employer identification number of the subcontractor; estimated dollar amount of the subcontract; estimated starting and completion dates of the subcontract; and the geographical area in which the subcontract is to be performed.

4. As used in this Notice, and in the contract resulting from this solicitation, the "covered area" is within the Commonwealth of Pennsylvania, County of Allegheny, City of Pittsburgh.

**HOUSING AUTHORITY OF THE CITY OF PITTSBURGH**

**Request for Proposals**

**AUTHORITY WIDE SITE IMPROVEMENTS**

**ATTACHMENT H**

**Sample MBE/WBE Letter of Intent**

DATE

<Name Of MBE or WBE Contact Person>

<Name of MBE or WBE firm>

<Address>

<City>, <State> <Zip>

Re: <Name of HACP Project>

Dear <Name of Contact Person at MBE or WBE Firm>

<Name of Prime Bidder> has submitted a bid for the above referenced project to the Housing Authority City of Pittsburgh (HACP).

If we are the successful bidders and awarded the contract, <Name of Prime Bidder> intends to utilize <Name of proposed MBE or WBE firm> as follows:

Scope of Proposed Services: \_\_\_\_\_

Estimated Dollar Value: \_\_\_\_\_

Please call should you have any further questions. We thank you for your continuing interest.

Sincerely,

<Contact Person from Prime Bidder>

<Contact Person from MBE/WBE>

\_\_\_\_\_  
(Signature)

\_\_\_\_\_  
(Signature)

\_\_\_\_\_  
(Name)

\_\_\_\_\_  
(Name)

**HOUSING AUTHORITY OF THE CITY OF PITTSBURGH**

**Request for Proposals**

**AUTHORITY WIDE SITE IMPROVEMENTS**

**ATTACHMENT I**

**Section 3 Clause  
Section 3 Opportunities Plan  
and Related Data**



All section 3 covered contracts shall include the following clause (referred to as the section 3 clause):

- A. The work to be performed under this contract is subject to the requirements of section 3 of the Housing and Urban Development Act of 1968, as amended, 12 U.S.C. 1701u (section 3). The purpose of section 3 is to ensure that employment and other economic opportunities generated by HUD assistance or HUD-assisted projects covered by section 3, shall, to the greatest extent feasible, be directed to low- and very low-income persons, particularly persons who are recipients of HUD assistance for housing.
- B. The parties to this contract agree to comply with HUD's regulations in 2 CFR part 200, which implement section 3. As evidenced by their execution of this contract, the parties to this contract certify that they are under no contractual or other impediment that would prevent them from complying with the part 2 CFR part 200 regulations.
- C. The contractor agrees to send to each labor organization or representative of workers with which the contractor has a collective bargaining agreement or other understanding, if any, a notice advising the labor organization or workers' representative of the contractor's commitments under this section 3 clause, and will post copies of the notice in conspicuous places at the work site where both employees and applicants for training and employment positions can see the notice. The notice shall describe the section 3 preference, shall set forth minimum number and job titles subject to hire, availability of apprenticeship and training positions, the qualifications for each; and the name and location of the person(s) taking applications for each of the positions; and the anticipated date the work shall begin.
- D. The contractor agrees to include this section 3 clause in every subcontract subject to compliance with regulations in 2 CFR part 200, and agrees to take appropriate action, as provided in an applicable provision of the subcontract or in this section 3 clause, upon a finding that the subcontractor is in violation of the regulations in 2 CFR part 200. The contractor will not subcontract with any subcontractor where the contractor has notice or knowledge that the subcontractor has been found in violation of the regulations in 2 CFR part 200.
- E. The contractor will certify that any vacant employment positions, including training positions, that are filled (1) after the contractor is selected but before the contract is executed, and (2) with persons other than those to whom the regulations of 2 CFR part 200 require employment opportunities to be directed, were not filled to circumvent the contractor's obligations under 2 CFR part 200.
- F. Noncompliance with HUD's regulations in 2 CFR part 200 may result in sanctions, termination of this contract for default, and debarment or suspension from future HUD assisted contracts.
- G. With respect to work performed in connection with section 3 covered Indian housing assistance, section 7(b) of the Indian Self- Determination and Education Assistance Act (25 U.S.C. 450e) also applies to the work to be performed under this contract. Section 7(b) requires that to the greatest extent feasible (i) preference and opportunities for training and employment shall be given to Indians, and (ii) preference in the award of contracts and subcontracts shall be given to Indian organizations and Indian-owned Economic Enterprises. Parties to this contract that are subject to the provisions of section 3 and section 7(b) agree to comply with section 3 to the maximum extent feasible, but not in derogation of compliance with section 7(b).

**Housing Authority City of Pittsburgh**  
**Development and Modernization Department**  
 Bidder's Section 3 Participation Form

**A. Bidder's Section 3 Hiring Plan**

Job Category	Total Estimated Positions Needed for Project	No. Positions Occupied by Permanent Employees*	Number of Positions Not Occupied	Number of Positions Available for Section 3 Residents
<b>Trade:</b>				
Journeyman				
Helper				
Apprentices				
Trainees				
Laborer				
Others				

\* Please submit a list of current employees to be assigned to this project including Dates of Hire

**B. Bidder's Section 3 Subcontracting Plan**

SUB - CONTRACTOR'S NAME**	SUB - CONTRACTORS ADDRESS	PHONE NUMBER	FEDERAL TAX ID NO./ SS#	DESCRIPTION OF WORK	Sub - Contract Amount

\*\* If the Bidder has not identified a Section 3 subcontractor, please indicate if there will be any Section 3 subcontracting opportunity and describe scope of work \_\_\_\_\_

\_\_\_\_\_  
Company Name

\_\_\_\_\_  
Project Name

\_\_\_\_\_  
Project Number

\_\_\_\_\_  
Name and Title of Person Completing this Form

\_\_\_\_\_  
Signature and Date

**PLACE HOLDER FOR**  
**ROSTER OF CURRENT EMPLOYEES**

**Pursuant to Housing Authority of the City of Pittsburgh Section 3 Program Manual, Part I, Section A - Section 3 Policy Statement (in part):**

*“HACP shall examine and consider a contractor’s potential for success in providing employment and business opportunities to those covered under Section 3 prior to acting on any proposed contract award. In response to any RFP, RFQ or IFB HACP will require submission of the Section 3 Opportunities Plan and roster of current employees, and certification that the bidder will comply with the requirements of Section 3.”*

### **Section 3 Participation**

With respect to work performed in connection with Section 3 covered Indian housing assistance, Section 7(b) of the Indian Self-Determination and Education Assistance Act (25 U.S.C. 450e) also applies to the work to be performed under this contract. Section 7(b) requires that to the greatest extent feasible (i) preference and opportunities for training and employment shall be given to Indians, and (ii) preference in the award of contracts and subcontracts shall be given to Indian organizations and Indian-owned Economic Enterprises. Parties to this contract that are subject to the provisions of Section 3 and Section 7(b) agree to comply with Section 3 to the maximum extent feasible, but not in derogation of compliance with Section 7(b).

### **RESIDENT HIRING REQUIREMENTS / RESIDENT HIRING SCALE**

<b>TOTAL LABOR DOLLARS USE TOTAL CONTRACT AMOUNT FOR SERVICE CONTRACTS</b>	<b>RESIDENT LABOR AS A % OF TOTAL LABOR DOLLARS</b>
Labor dollars \$25,000 but less than \$100,000	10% of the labor dollars
\$100,000, but less than \$200,000	9% of the labor dollars
At least \$200,000, but less than \$300,000	8% of the labor dollars
At least \$300,000, but less than \$400,000	7% of the labor dollars
At least \$400,000, but less than \$500,000	6% of the labor dollars
At least \$500,000, but less than \$1 million	5% of the labor dollars
At least \$1 million, but less than \$2 million	4% of the labor dollars
At least \$2 million, but less than \$4 million	3% of the labor dollars
At least \$4 million, but less than \$7 million	2% of the labor dollars
\$7 million or more	½ to 1 % of the labor dollars

A copy of HACP's Section 3 Program Manual is available for download at [www.HACP.org](http://www.HACP.org).



## SECTION 3 OPPORTUNITIES PLAN

### Business Opportunities and Employment Training for Housing Authority of the City of Pittsburgh Low Income Public Housing Residents (LIPH) and Area Residents of Low and Very Low Income Status (ARLIS)

PRIME CONTRACTOR'S NAME: \_\_\_\_\_  
SPECIFICATION OR RFP/IFB/RFQ NUMBER: \_\_\_\_\_  
SPECIFICATION OR RFP/IFB/RFQ TITLE: \_\_\_\_\_

The Contractor hereby agrees to comply with all the provisions of Section 3 as set forth in 2 CFR 200 et seq. and the HACP Section 3 Policy and Program requirements. The Contractor hereby submits this document to identify employment opportunities for HACP residents (LIPH) and **Area Residents of Low and Very Low Income Status (ARLIS)** during the term of the contract between the Contractor and the HACP.

The preference of HACP is to ensure that as many HACP residents as possible are employed. In an effort to further that requirement, HACP has created a preference tier structure as outlined in the HACP Section 3 Policy and Program Manual which can be reviewed by visiting the "Vendor Services" section of [www.hacp.org](http://www.hacp.org). Contractors are required to comply with Section 3 by first considering Tier I – Hiring. If the Contractor cannot meet its Section 3 requirement in Tier I and needs to move to Tier II or Tier III, that Contractor must document this inability to comply with the preference and the need to move to a lower tier. (Such inability **must** be documented for moves within tiers). The Contractor agrees to meet its Section 3 requirement following the Preferential Tier Structure as indicated by the selection below (check one or more tiers below):

#### Tier I – HIRING

The Contractor affirms that the jobs identified shall be for meaningful employment that may or may not be related to the scope of services covered under Contract/Purchase Order # \_\_\_\_\_. The Contractor has committed to employ \_\_\_\_\_ resident(s) in order to comply with its Section 3 requirements. A prime contractor may satisfy the HACP Resident Hiring Requirements through his/her subcontractors. **Contact the HACP Resident Employment Program for resident referrals at 412-395-3950, Ext 1048.**

When Tier I is selected, the Contractor shall complete the following table as instructed below:

- (1) Indicate each job title for all phases of this contract
- (2) The number of positions that will be needed in each category
- (3) How many of those positions are currently filled
- (4) The number currently filled by low and very low-income HACP residents
- (5) The number currently filled by City of Pittsburgh neighborhood area residents
- (6) How many positions need to be filled

Indicate your requirement for the number of positions you intend to fill with:

- (7) Low income HACP Residents (LIPH) and/or
- (8) Low and very low income City of Pittsburgh Neighborhood Area Residents (ARLIS)



## SECTION 3 OPPORTUNITIES PLAN

Section 3 Labor Utilization Assessment and Plan							
SPEC or RFP TITLE:				SPEC or RFP NUMBER:			
JOB TITLE (1)	NUMBER OF POSITIONS					HIRING REQUIREMENT	
	# NEEDED (2)	CURRENTLY FILLED			TO BE FILLED (6)	LIPH (7)	ARLIS (8)
		TOTAL (3)	LIPH (4)	ARLIS (5)			

**LIPH – HACP low income public housing resident**  
**ARLIS - Area Residents of Low/Very Low Income Status – (Area is the Pittsburgh metropolitan area)**

In the event the value of Section 3 resident hiring is less than the amount identified in the Resident Hiring Scale, vendors must contribute to the HACP Education Fund an amount not less than the difference between the value of Section 3 hiring and the amount identified in the Resident Hiring Scale, which funds shall be used to provide other economic opportunities.

Therefore, if it is anticipated that any position listed above shall be for less than the full term of the contract period, you must indicate on the lines below, the anticipated term for each position:

---

---



## SECTION 3 OPPORTUNITIES PLAN

### [ ] Tier II – CONTRACTING

The contractor has identified \_\_\_\_\_ HACP resident-owned business(es) or \_\_\_\_\_ Section 3 business(es) which is/are 51 percent or more owned by Section 3 residents or 30 percent or more of their permanent full-time workforce are Section 3 residents. This will satisfy the contractor's Section 3 requirement covered under Contract/Purchase Order # \_\_\_\_\_.

**In a one (1) page letter on your firm's letterhead:**

- 1) Indicate the requirements, expressed in terms of percentage, of planned contracting dollars for the use of Section 3 business concerns as subcontractors.
- 2) A statement of the total dollar amount to be contracted, total dollar amount to be contracted to Section 3 business concerns for building trades, and total dollar amount to be contracted to Section 3 business concerns for other than building trades work (maintenance, repair, modernization, and development).
- 3) A description of the method used to develop the requirements above and the efforts to be undertaken by the contractor to meet those requirements.

### [ ] Tier III - OTHER ECONOMIC OPPORTUNITIES

Firms may provide other economic opportunities to train and employ Section 3 residents or make a direct cash contribution to the HACP Education Fund. HACP has established the following minimum threshold requirements for provision of training or contribution to the HACP fund that provides other economic opportunities:

- a) Contractor incurs the cost of providing skilled training for residents in an amount commensurate with the sliding scale set forth in the Resident Hiring Scale; or,
- b) Contractor makes a contribution to the HACP Education Fund at Clean Slate E3 to provide assistance to residents to obtain training. The level of contribution would be commensurate with the sliding scale set forth in the Resident Hiring Scale.

Contractor shall provide, in a letter on firm letterhead:

- 1) Indication of the skilled training to be provided, the number of persons to be trained, the training provider, the cost of training, and the trainee recruitment plan; or,
- 2) Provide the amount of planned contribution to be made in relation to percentage of the contract labor hours costs. (Contribution checks should be made payable to: Clean Slate E3 Education Fund and mailed to Clean Slate E3, C/O Housing Authority of the City of Pittsburgh, Finance Department, 200 Ross Street, 9<sup>th</sup> Floor, Pittsburgh, PA 15219.

### [ ] Tier IV – No New Hire Opportunity

If awarded this contract, the contractor will be able to fulfill the requirements of the IFB/RFP/RFQ with the existing work force. No new hires will be employed as a result of this award. If this position changes and hiring opportunities become necessary, the HACP Resident Employment Program will be notified.



## SECTION 3 OPPORTUNITIES PLAN

**By signing below, the Contractor hereby agrees to comply with the selected Section 3 requirements indicated above. To the extent that the completion of this form is contingent upon future information, for example price negotiations, request for specific services, etc., the undersigned hereby affirms and agrees to fully adhere to the spirit and intent of the HACP Section 3 Policy.**

**Furthermore, the undersigned acknowledges and affirms responsibility for completion and submission of this form as part of the response documentation for this Invitation for Bid or Request for Proposal. Failure to submit this form may jeopardize the responsiveness of your submission.**

Company Name: \_\_\_\_\_

Name: \_\_\_\_\_

Title: \_\_\_\_\_

Signature: \_\_\_\_\_ Date: \_\_\_\_\_

Witness Name: \_\_\_\_\_

Witness Signature: \_\_\_\_\_ Date: \_\_\_\_\_



**HOUSING AUTHORITY OF THE CITY OF PITTSBURGH**

**Request for Proposals**

**AUTHORITY WIDE SITE IMPROVEMENTS**

**ATTACHMENT J**

**Firm Demographics Form**

Firm Demographics																		
	All Employees	Male						Female						Total # of American Minorities				
		White American	African American	Hispanic American	Asian American	Native American	Other American Minority	Foreign	Total Males	White American	African American	Hispanic American	Asian American		Native American	Other American Minority	Foreign	Total Females
Partner																		
Associate																		
Professional																		
Secretarial																		
Clerical																		
Other																		
Total																		

**Explain all Other American Minority:** \_\_\_\_\_  
 \_\_\_\_\_  
 \_\_\_\_\_

**Be certain that the numbers in this table are accurate and add up correctly.**

**HOUSING AUTHORITY OF THE CITY OF PITTSBURGH**

**Request for Proposals**

**AUTHORITY WIDE SITE IMPROVEMENTS**

**ATTACHMENT K**

**Request for Taxpayer Identification Number and Certification (IRS W-9)**

## Request for Taxpayer Identification Number and Certification

**Give Form to the requester. Do not send to the IRS.**

<b>Print or type</b>	<b>1</b> Name (as shown on your income tax return). Name is required on this line; do not leave this line blank.
<b>See Specific Instructions on page 2.</b>	<b>2</b> Business name/disregarded entity name, if different from above
	<b>3</b> Check appropriate box for federal tax classification; check only <b>one</b> of the following seven boxes: <input type="checkbox"/> Individual/sole proprietor or single-member LLC <input type="checkbox"/> C Corporation <input type="checkbox"/> S Corporation <input type="checkbox"/> Partnership <input type="checkbox"/> Trust/estate <input type="checkbox"/> Limited liability company. Enter the tax classification (C=C corporation, S=S corporation, P=partnership) ▶ _____ <b>Note.</b> For a single-member LLC that is disregarded, do not check LLC; check the appropriate box in the line above for the tax classification of the single-member owner. <input type="checkbox"/> Other (see instructions) ▶ _____
	<b>4</b> Exemptions (codes apply only to certain entities, not individuals; see instructions on page 3): Exempt payee code (if any) _____ Exemption from FATCA reporting code (if any) _____ <i>(Applies to accounts maintained outside the U.S.)</i>
	<b>5</b> Address (number, street, and apt. or suite no.) _____ _____ _____
	Requester's name and address (optional) _____ _____ _____
	<b>6</b> City, state, and ZIP code _____
	<b>7</b> List account number(s) here (optional) _____

### Part I Taxpayer Identification Number (TIN)

Enter your TIN in the appropriate box. The TIN provided must match the name given on line 1 to avoid backup withholding. For individuals, this is generally your social security number (SSN). However, for a resident alien, sole proprietor, or disregarded entity, see the Part I instructions on page 3. For other entities, it is your employer identification number (EIN). If you do not have a number, see *How to get a TIN* on page 3.

<b>Social security number</b>										
			-		-					
<b>or</b>										
<b>Employer identification number</b>										
			-							

**Note.** If the account is in more than one name, see the instructions for line 1 and the chart on page 4 for guidelines on whose number to enter.

### Part II Certification

Under penalties of perjury, I certify that:

- The number shown on this form is my correct taxpayer identification number (or I am waiting for a number to be issued to me); and
- I am not subject to backup withholding because: (a) I am exempt from backup withholding, or (b) I have not been notified by the Internal Revenue Service (IRS) that I am subject to backup withholding as a result of a failure to report all interest or dividends, or (c) the IRS has notified me that I am no longer subject to backup withholding; and
- I am a U.S. citizen or other U.S. person (defined below); and
- The FATCA code(s) entered on this form (if any) indicating that I am exempt from FATCA reporting is correct.

**Certification instructions.** You must cross out item 2 above if you have been notified by the IRS that you are currently subject to backup withholding because you have failed to report all interest and dividends on your tax return. For real estate transactions, item 2 does not apply. For mortgage interest paid, acquisition or abandonment of secured property, cancellation of debt, contributions to an individual retirement arrangement (IRA), and generally, payments other than interest and dividends, you are not required to sign the certification, but you must provide your correct TIN. See the instructions on page 3.

<b>Sign Here</b>	Signature of U.S. person ▶ _____	Date ▶ _____
------------------	----------------------------------	--------------

### General Instructions

Section references are to the Internal Revenue Code unless otherwise noted.  
**Future developments.** Information about developments affecting Form W-9 (such as legislation enacted after we release it) is at [www.irs.gov/fw9](http://www.irs.gov/fw9).

#### Purpose of Form

An individual or entity (Form W-9 requester) who is required to file an information return with the IRS must obtain your correct taxpayer identification number (TIN) which may be your social security number (SSN), individual taxpayer identification number (ITIN), adoption taxpayer identification number (ATIN), or employer identification number (EIN), to report on an information return the amount paid to you, or other amount reportable on an information return. Examples of information returns include, but are not limited to, the following:

- Form 1099-INT (interest earned or paid)
- Form 1099-DIV (dividends, including those from stocks or mutual funds)
- Form 1099-MISC (various types of income, prizes, awards, or gross proceeds)
- Form 1099-B (stock or mutual fund sales and certain other transactions by brokers)
- Form 1099-S (proceeds from real estate transactions)
- Form 1099-K (merchant card and third party network transactions)

- Form 1098 (home mortgage interest), 1098-E (student loan interest), 1098-T (tuition)
- Form 1099-C (canceled debt)
- Form 1099-A (acquisition or abandonment of secured property)

Use Form W-9 only if you are a U.S. person (including a resident alien), to provide your correct TIN.

If you do not return Form W-9 to the requester with a TIN, you might be subject to backup withholding. See *What is backup withholding?* on page 2.

By signing the filled-out form, you:

- Certify that the TIN you are giving is correct (or you are waiting for a number to be issued),
- Certify that you are not subject to backup withholding, or
- Claim exemption from backup withholding if you are a U.S. exempt payee. If applicable, you are also certifying that as a U.S. person, your allocable share of any partnership income from a U.S. trade or business is not subject to the withholding tax on foreign partners' share of effectively connected income, and
- Certify that FATCA code(s) entered on this form (if any) indicating that you are exempt from the FATCA reporting, is correct. See *What is FATCA reporting?* on page 2 for further information.

**Note.** If you are a U.S. person and a requester gives you a form other than Form W-9 to request your TIN, you must use the requester's form if it is substantially similar to this Form W-9.

**Definition of a U.S. person.** For federal tax purposes, you are considered a U.S. person if you are:

- An individual who is a U.S. citizen or U.S. resident alien;
- A partnership, corporation, company, or association created or organized in the United States or under the laws of the United States;
- An estate (other than a foreign estate); or
- A domestic trust (as defined in Regulations section 301.7701-7).

**Special rules for partnerships.** Partnerships that conduct a trade or business in the United States are generally required to pay a withholding tax under section 1446 on any foreign partners' share of effectively connected taxable income from such business. Further, in certain cases where a Form W-9 has not been received, the rules under section 1446 require a partnership to presume that a partner is a foreign person, and pay the section 1446 withholding tax. Therefore, if you are a U.S. person that is a partner in a partnership conducting a trade or business in the United States, provide Form W-9 to the partnership to establish your U.S. status and avoid section 1446 withholding on your share of partnership income.

In the cases below, the following person must give Form W-9 to the partnership for purposes of establishing its U.S. status and avoiding withholding on its allocable share of net income from the partnership conducting a trade or business in the United States:

- In the case of a disregarded entity with a U.S. owner, the U.S. owner of the disregarded entity and not the entity;
- In the case of a grantor trust with a U.S. grantor or other U.S. owner, generally, the U.S. grantor or other U.S. owner of the grantor trust and not the trust; and
- In the case of a U.S. trust (other than a grantor trust), the U.S. trust (other than a grantor trust) and not the beneficiaries of the trust.

**Foreign person.** If you are a foreign person or the U.S. branch of a foreign bank that has elected to be treated as a U.S. person, do not use Form W-9. Instead, use the appropriate Form W-8 or Form 8233 (see Publication 515, Withholding of Tax on Nonresident Aliens and Foreign Entities).

**Nonresident alien who becomes a resident alien.** Generally, only a nonresident alien individual may use the terms of a tax treaty to reduce or eliminate U.S. tax on certain types of income. However, most tax treaties contain a provision known as a "saving clause." Exceptions specified in the saving clause may permit an exemption from tax to continue for certain types of income even after the payee has otherwise become a U.S. resident alien for tax purposes.

If you are a U.S. resident alien who is relying on an exception contained in the saving clause of a tax treaty to claim an exemption from U.S. tax on certain types of income, you must attach a statement to Form W-9 that specifies the following five items:

1. The treaty country. Generally, this must be the same treaty under which you claimed exemption from tax as a nonresident alien.
2. The treaty article addressing the income.
3. The article number (or location) in the tax treaty that contains the saving clause and its exceptions.
4. The type and amount of income that qualifies for the exemption from tax.
5. Sufficient facts to justify the exemption from tax under the terms of the treaty article.

**Example.** Article 20 of the U.S.-China income tax treaty allows an exemption from tax for scholarship income received by a Chinese student temporarily present in the United States. Under U.S. law, this student will become a resident alien for tax purposes if his or her stay in the United States exceeds 5 calendar years. However, paragraph 2 of the first Protocol to the U.S.-China treaty (dated April 30, 1984) allows the provisions of Article 20 to continue to apply even after the Chinese student becomes a resident alien of the United States. A Chinese student who qualifies for this exception (under paragraph 2 of the first protocol) and is relying on this exception to claim an exemption from tax on his or her scholarship or fellowship income would attach to Form W-9 a statement that includes the information described above to support that exemption.

If you are a nonresident alien or a foreign entity, give the requester the appropriate completed Form W-8 or Form 8233.

## Backup Withholding

**What is backup withholding?** Persons making certain payments to you must under certain conditions withhold and pay to the IRS 28% of such payments. This is called "backup withholding." Payments that may be subject to backup withholding include interest, tax-exempt interest, dividends, broker and barter exchange transactions, rents, royalties, nonemployee pay, payments made in settlement of payment card and third party network transactions, and certain payments from fishing boat operators. Real estate transactions are not subject to backup withholding.

You will not be subject to backup withholding on payments you receive if you give the requester your correct TIN, make the proper certifications, and report all your taxable interest and dividends on your tax return.

**Payments you receive will be subject to backup withholding if:**

1. You do not furnish your TIN to the requester,
2. You do not certify your TIN when required (see the Part II instructions on page 3 for details),

3. The IRS tells the requester that you furnished an incorrect TIN,

4. The IRS tells you that you are subject to backup withholding because you did not report all your interest and dividends on your tax return (for reportable interest and dividends only), or

5. You do not certify to the requester that you are not subject to backup withholding under 4 above (for reportable interest and dividend accounts opened after 1983 only).

Certain payees and payments are exempt from backup withholding. See *Exempt payee code* on page 3 and the separate Instructions for the Requester of Form W-9 for more information.

Also see *Special rules for partnerships* above.

## What is FATCA reporting?

The Foreign Account Tax Compliance Act (FATCA) requires a participating foreign financial institution to report all United States account holders that are specified United States persons. Certain payees are exempt from FATCA reporting. See *Exemption from FATCA reporting code* on page 3 and the Instructions for the Requester of Form W-9 for more information.

## Updating Your Information

You must provide updated information to any person to whom you claimed to be an exempt payee if you are no longer an exempt payee and anticipate receiving reportable payments in the future from this person. For example, you may need to provide updated information if you are a C corporation that elects to be an S corporation, or if you no longer are tax exempt. In addition, you must furnish a new Form W-9 if the name or TIN changes for the account; for example, if the grantor of a grantor trust dies.

## Penalties

**Failure to furnish TIN.** If you fail to furnish your correct TIN to a requester, you are subject to a penalty of \$50 for each such failure unless your failure is due to reasonable cause and not to willful neglect.

**Civil penalty for false information with respect to withholding.** If you make a false statement with no reasonable basis that results in no backup withholding, you are subject to a \$500 penalty.

**Criminal penalty for falsifying information.** Willfully falsifying certifications or affirmations may subject you to criminal penalties including fines and/or imprisonment.

**Misuse of TINs.** If the requester discloses or uses TINs in violation of federal law, the requester may be subject to civil and criminal penalties.

## Specific Instructions

### Line 1

You must enter one of the following on this line; **do not** leave this line blank. The name should match the name on your tax return.

If this Form W-9 is for a joint account, list first, and then circle, the name of the person or entity whose number you entered in Part I of Form W-9.

a. **Individual.** Generally, enter the name shown on your tax return. If you have changed your last name without informing the Social Security Administration (SSA) of the name change, enter your first name, the last name as shown on your social security card, and your new last name.

**Note. ITIN applicant:** Enter your individual name as it was entered on your Form W-7 application, line 1a. This should also be the same as the name you entered on the Form 1040/1040A/1040EZ you filed with your application.

b. **Sole proprietor or single-member LLC.** Enter your individual name as shown on your 1040/1040A/1040EZ on line 1. You may enter your business, trade, or "doing business as" (DBA) name on line 2.

c. **Partnership, LLC that is not a single-member LLC, C Corporation, or S Corporation.** Enter the entity's name as shown on the entity's tax return on line 1 and any business, trade, or DBA name on line 2.

d. **Other entities.** Enter your name as shown on required U.S. federal tax documents on line 1. This name should match the name shown on the charter or other legal document creating the entity. You may enter any business, trade, or DBA name on line 2.

e. **Disregarded entity.** For U.S. federal tax purposes, an entity that is disregarded as an entity separate from its owner is treated as a "disregarded entity." See Regulations section 301.7701-2(c)(2)(iii). Enter the owner's name on line 1. The name of the entity entered on line 1 should never be a disregarded entity. The name on line 1 should be the name shown on the income tax return on which the income should be reported. For example, if a foreign LLC that is treated as a disregarded entity for U.S. federal tax purposes has a single owner that is a U.S. person, the U.S. owner's name is required to be provided on line 1. If the direct owner of the entity is also a disregarded entity, enter the first owner that is not disregarded for federal tax purposes. Enter the disregarded entity's name on line 2, "Business name/disregarded entity name." If the owner of the disregarded entity is a foreign person, the owner must complete an appropriate Form W-8 instead of a Form W-9. This is the case even if the foreign person has a U.S. TIN.

**Line 2**

If you have a business name, trade name, DBA name, or disregarded entity name, you may enter it on line 2.

**Line 3**

Check the appropriate box in line 3 for the U.S. federal tax classification of the person whose name is entered on line 1. Check only one box in line 3.

**Limited Liability Company (LLC).** If the name on line 1 is an LLC treated as a partnership for U.S. federal tax purposes, check the "Limited Liability Company" box and enter "P" in the space provided. If the LLC has filed Form 8832 or 2553 to be taxed as a corporation, check the "Limited Liability Company" box and in the space provided enter "C" for C corporation or "S" for S corporation. If it is a single-member LLC that is a disregarded entity, do not check the "Limited Liability Company" box; instead check the first box in line 3 "Individual/sole proprietor or single-member LLC."

**Line 4, Exemptions**

If you are exempt from backup withholding and/or FATCA reporting, enter in the appropriate space in line 4 any code(s) that may apply to you.

**Exempt payee code.**

- Generally, individuals (including sole proprietors) are not exempt from backup withholding.
- Except as provided below, corporations are exempt from backup withholding for certain payments, including interest and dividends.
- Corporations are not exempt from backup withholding for payments made in settlement of payment card or third party network transactions.
- Corporations are not exempt from backup withholding with respect to attorneys' fees or gross proceeds paid to attorneys, and corporations that provide medical or health care services are not exempt with respect to payments reportable on Form 1099-MISC.

The following codes identify payees that are exempt from backup withholding. Enter the appropriate code in the space in line 4.

- 1—An organization exempt from tax under section 501(a), any IRA, or a custodial account under section 403(b)(7) if the account satisfies the requirements of section 401(f)(2)
- 2—The United States or any of its agencies or instrumentalities
- 3—A state, the District of Columbia, a U.S. commonwealth or possession, or any of their political subdivisions or instrumentalities
- 4—A foreign government or any of its political subdivisions, agencies, or instrumentalities
- 5—A corporation
- 6—A dealer in securities or commodities required to register in the United States, the District of Columbia, or a U.S. commonwealth or possession
- 7—A futures commission merchant registered with the Commodity Futures Trading Commission
- 8—A real estate investment trust
- 9—An entity registered at all times during the tax year under the Investment Company Act of 1940
- 10—A common trust fund operated by a bank under section 584(a)
- 11—A financial institution
- 12—A middleman known in the investment community as a nominee or custodian
- 13—A trust exempt from tax under section 664 or described in section 4947

The following chart shows types of payments that may be exempt from backup withholding. The chart applies to the exempt payees listed above, 1 through 13.

IF the payment is for . . .	THEN the payment is exempt for . . .
Interest and dividend payments	All exempt payees except for 7
Broker transactions	Exempt payees 1 through 4 and 6 through 11 and all C corporations. S corporations must not enter an exempt payee code because they are exempt only for sales of noncovered securities acquired prior to 2012.
Barter exchange transactions and patronage dividends	Exempt payees 1 through 4
Payments over \$600 required to be reported and direct sales over \$5,000 <sup>1</sup>	Generally, exempt payees 1 through 5 <sup>2</sup>
Payments made in settlement of payment card or third party network transactions	Exempt payees 1 through 4

<sup>1</sup> See Form 1099-MISC, Miscellaneous Income, and its instructions.

<sup>2</sup> However, the following payments made to a corporation and reportable on Form 1099-MISC are not exempt from backup withholding: medical and health care payments, attorneys' fees, gross proceeds paid to an attorney reportable under section 6045(f), and payments for services paid by a federal executive agency.

**Exemption from FATCA reporting code.** The following codes identify payees that are exempt from reporting under FATCA. These codes apply to persons submitting this form for accounts maintained outside of the United States by certain foreign financial institutions. Therefore, if you are only submitting this form for an account you hold in the United States, you may leave this field blank. Consult with the person requesting this form if you are uncertain if the financial institution is subject to these requirements. A requester may indicate that a code is not required by providing you with a Form W-9 with "Not Applicable" (or any similar indication) written or printed on the line for a FATCA exemption code.

A—An organization exempt from tax under section 501(a) or any individual retirement plan as defined in section 7701(a)(37)

B—The United States or any of its agencies or instrumentalities

C—A state, the District of Columbia, a U.S. commonwealth or possession, or any of their political subdivisions or instrumentalities

D—A corporation the stock of which is regularly traded on one or more established securities markets, as described in Regulations section 1.1472-1(c)(1)(i)

E—A corporation that is a member of the same expanded affiliated group as a corporation described in Regulations section 1.1472-1(c)(1)(i)

F—A dealer in securities, commodities, or derivative financial instruments (including notional principal contracts, futures, forwards, and options) that is registered as such under the laws of the United States or any state

G—A real estate investment trust

H—A regulated investment company as defined in section 851 or an entity registered at all times during the tax year under the Investment Company Act of 1940

I—A common trust fund as defined in section 584(a)

J—A bank as defined in section 581

K—A broker

L—A trust exempt from tax under section 664 or described in section 4947(a)(1)

M—A tax exempt trust under a section 403(b) plan or section 457(g) plan

**Note.** You may wish to consult with the financial institution requesting this form to determine whether the FATCA code and/or exempt payee code should be completed.

**Line 5**

Enter your address (number, street, and apartment or suite number). This is where the requester of this Form W-9 will mail your information returns.

**Line 6**

Enter your city, state, and ZIP code.

**Part I. Taxpayer Identification Number (TIN)**

**Enter your TIN in the appropriate box.** If you are a resident alien and you do not have and are not eligible to get an SSN, your TIN is your IRS individual taxpayer identification number (ITIN). Enter it in the social security number box. If you do not have an ITIN, see *How to get a TIN* below.

If you are a sole proprietor and you have an EIN, you may enter either your SSN or EIN. However, the IRS prefers that you use your SSN.

If you are a single-member LLC that is disregarded as an entity separate from its owner (see *Limited Liability Company (LLC)* on this page), enter the owner's SSN (or EIN, if the owner has one). Do not enter the disregarded entity's EIN. If the LLC is classified as a corporation or partnership, enter the entity's EIN.

**Note.** See the chart on page 4 for further clarification of name and TIN combinations.

**How to get a TIN.** If you do not have a TIN, apply for one immediately. To apply for an SSN, get Form SS-5, Application for a Social Security Card, from your local SSA office or get this form online at [www.ssa.gov](http://www.ssa.gov). You may also get this form by calling 1-800-772-1213. Use Form W-7, Application for IRS Individual Taxpayer Identification Number, to apply for an ITIN, or Form SS-4, Application for Employer Identification Number, to apply for an EIN. You can apply for an EIN online by accessing the IRS website at [www.irs.gov/businesses](http://www.irs.gov/businesses) and clicking on Employer Identification Number (EIN) under Starting a Business. You can get Forms W-7 and SS-4 from the IRS by visiting [IRS.gov](http://IRS.gov) or by calling 1-800-TAX-FORM (1-800-829-3676).

If you are asked to complete Form W-9 but do not have a TIN, apply for a TIN and write "Applied For" in the space for the TIN, sign and date the form, and give it to the requester. For interest and dividend payments, and certain payments made with respect to readily tradable instruments, generally you will have 60 days to get a TIN and give it to the requester before you are subject to backup withholding on payments. The 60-day rule does not apply to other types of payments. You will be subject to backup withholding on all such payments until you provide your TIN to the requester.

**Note.** Entering "Applied For" means that you have already applied for a TIN or that you intend to apply for one soon.

**Caution:** A disregarded U.S. entity that has a foreign owner must use the appropriate Form W-8.

**Part II. Certification**

To establish to the withholding agent that you are a U.S. person, or resident alien, sign Form W-9. You may be requested to sign by the withholding agent even if items 1, 4, or 5 below indicate otherwise.

For a joint account, only the person whose TIN is shown in Part I should sign (when required). In the case of a disregarded entity, the person identified on line 1 must sign. Exempt payees, see *Exempt payee code* earlier.

**Signature requirements.** Complete the certification as indicated in items 1 through 5 below.

- 1. Interest, dividend, and barter exchange accounts opened before 1984 and broker accounts considered active during 1983.** You must give your correct TIN, but you do not have to sign the certification.
- 2. Interest, dividend, broker, and barter exchange accounts opened after 1983 and broker accounts considered inactive during 1983.** You must sign the certification or backup withholding will apply. If you are subject to backup withholding and you are merely providing your correct TIN to the requester, you must cross out item 2 in the certification before signing the form.
- 3. Real estate transactions.** You must sign the certification. You may cross out item 2 of the certification.
- 4. Other payments.** You must give your correct TIN, but you do not have to sign the certification unless you have been notified that you have previously given an incorrect TIN. "Other payments" include payments made in the course of the requester's trade or business for rents, royalties, goods (other than bills for merchandise), medical and health care services (including payments to corporations), payments to a nonemployee for services, payments made in settlement of payment card and third party network transactions, payments to certain fishing boat crew members and fishermen, and gross proceeds paid to attorneys (including payments to corporations).
- 5. Mortgage interest paid by you, acquisition or abandonment of secured property, cancellation of debt, qualified tuition program payments (under section 529), IRA, Coverdell ESA, Archer MSA or HSA contributions or distributions, and pension distributions.** You must give your correct TIN, but you do not have to sign the certification.

**What Name and Number To Give the Requester**

For this type of account:	Give name and SSN of:
1. Individual	The individual
2. Two or more individuals (joint account)	The actual owner of the account or, if combined funds, the first individual on the account <sup>1</sup>
3. Custodian account of a minor (Uniform Gift to Minors Act)	The minor <sup>2</sup>
4. a. The usual revocable savings trust (grantor is also trustee) b. So-called trust account that is not a legal or valid trust under state law	The grantor-trustee <sup>1</sup> The actual owner <sup>1</sup>
5. Sole proprietorship or disregarded entity owned by an individual	The owner <sup>3</sup>
6. Grantor trust filing under Optional Form 1099 Filing Method 1 (see Regulations section 1.671-4(b)(2)(i)(A))	The grantor*
For this type of account:	Give name and EIN of:
7. Disregarded entity not owned by an individual	The owner
8. A valid trust, estate, or pension trust	Legal entity <sup>4</sup>
9. Corporation or LLC electing corporate status on Form 8832 or Form 2553	The corporation
10. Association, club, religious, charitable, educational, or other tax-exempt organization	The organization
11. Partnership or multi-member LLC	The partnership
12. A broker or registered nominee	The broker or nominee
13. Account with the Department of Agriculture in the name of a public entity (such as a state or local government, school district, or prison) that receives agricultural program payments	The public entity
14. Grantor trust filing under the Form 1041 Filing Method or the Optional Form 1099 Filing Method 2 (see Regulations section 1.671-4(b)(2)(i)(B))	The trust

<sup>1</sup> List first and circle the name of the person whose number you furnish. If only one person on a joint account has an SSN, that person's number must be furnished.  
<sup>2</sup> Circle the minor's name and furnish the minor's SSN.

<sup>3</sup> You must show your individual name and you may also enter your business or DBA name on the "Business name/disregarded entity" name line. You may use either your SSN or EIN (if you have one), but the IRS encourages you to use your SSN.

<sup>4</sup> List first and circle the name of the trust, estate, or pension trust. (Do not furnish the TIN of the personal representative or trustee unless the legal entity itself is not designated in the account title.) Also see *Special rules for partnerships* on page 2.

\*Note. Grantor also must provide a Form W-9 to trustee of trust.

**Note.** If no name is circled when more than one name is listed, the number will be considered to be that of the first name listed.

**Secure Your Tax Records from Identity Theft**

Identity theft occurs when someone uses your personal information such as your name, SSN, or other identifying information, without your permission, to commit fraud or other crimes. An identity thief may use your SSN to get a job or may file a tax return using your SSN to receive a refund.

To reduce your risk:

- Protect your SSN,
- Ensure your employer is protecting your SSN, and
- Be careful when choosing a tax preparer.

If your tax records are affected by identity theft and you receive a notice from the IRS, respond right away to the name and phone number printed on the IRS notice or letter.

If your tax records are not currently affected by identity theft but you think you are at risk due to a lost or stolen purse or wallet, questionable credit card activity or credit report, contact the IRS Identity Theft Hotline at 1-800-908-4490 or submit Form 14039.

For more information, see Publication 4535, Identity Theft Prevention and Victim Assistance.

Victims of identity theft who are experiencing economic harm or a system problem, or are seeking help in resolving tax problems that have not been resolved through normal channels, may be eligible for Taxpayer Advocate Service (TAS) assistance. You can reach TAS by calling the TAS toll-free case intake line at 1-877-777-4778 or TTY/TDD 1-800-829-4059.

**Protect yourself from suspicious emails or phishing schemes.** Phishing is the creation and use of email and websites designed to mimic legitimate business emails and websites. The most common act is sending an email to a user falsely claiming to be an established legitimate enterprise in an attempt to scam the user into surrendering private information that will be used for identity theft.

The IRS does not initiate contacts with taxpayers via emails. Also, the IRS does not request personal detailed information through email or ask taxpayers for the PIN numbers, passwords, or similar secret access information for their credit card, bank, or other financial accounts.

If you receive an unsolicited email claiming to be from the IRS, forward this message to [phishing@irs.gov](mailto:phishing@irs.gov). You may also report misuse of the IRS name, logo, or other IRS property to the Treasury Inspector General for Tax Administration (TIGTA) at 1-800-366-4484. You can forward suspicious emails to the Federal Trade Commission at: [spam@uce.gov](mailto:spam@uce.gov) or contact them at [www.ftc.gov/idtheft](http://www.ftc.gov/idtheft) or 1-877-IDTHEFT (1-877-438-4338).

Visit [IRS.gov](http://IRS.gov) to learn more about identity theft and how to reduce your risk.

**Privacy Act Notice**

Section 6109 of the Internal Revenue Code requires you to provide your correct TIN to persons (including federal agencies) who are required to file information returns with the IRS to report interest, dividends, or certain other income paid to you; mortgage interest you paid; the acquisition or abandonment of secured property; the cancellation of debt; or contributions you made to an IRA, Archer MSA, or HSA. The person collecting this form uses the information on the form to file information returns with the IRS, reporting the above information. Routine uses of this information include giving it to the Department of Justice for civil and criminal litigation and to cities, states, the District of Columbia, and U.S. commonwealths and possessions for use in administering their laws. The information also may be disclosed to other countries under a treaty, to federal and state agencies to enforce civil and criminal laws, or to federal law enforcement and intelligence agencies to combat terrorism. You must provide your TIN whether or not you are required to file a tax return. Under section 3406, payers must generally withhold a percentage of taxable interest, dividend, and certain other payments to a payee who does not give a TIN to the payer. Certain penalties may also apply for providing false or fraudulent information.

**HOUSING AUTHORITY OF THE CITY OF PITTSBURGH**

**Request for Proposals**

**AUTHORITY WIDE SITE IMPROVEMENTS**

**ATTACHMENT L**

**Davis-Bacon Wage Determinations**



# Residential

"General Decision Number: PA20190012 06/07/2019

Superseded General Decision Number: PA20180033

State: Pennsylvania

Construction Type: Residential

County: Allegheny County in Pennsylvania.

RESIDENTIAL CONSTRUCTION PROJECTS (consisting of single family homes and apartments up to and including 4 stories)

Note: Under Executive Order (EO) 13658, an hourly minimum wage of \$10.60 for calendar year 2019 applies to all contracts subject to the Davis-Bacon Act for which the contract is awarded (and any solicitation was issued) on or after January 1, 2015. If this contract is covered by the EO, the contractor must pay all workers in any classification listed on this wage determination at least \$10.60 per hour (or the applicable wage rate listed on this wage determination, if it is higher) for all hours spent performing on the contract in calendar year 2019. If this contract is covered by the EO and a classification considered necessary for performance of work on the contract does not appear on this wage determination, the contractor must pay workers in that classification at least the wage rate determined through the conformance process set forth in 29 CFR 5.5(a)(1)(ii) (or the EO minimum wage rate, if it is higher than the conformed wage rate). The EO minimum wage rate will be adjusted annually. Please note that this EO applies to the above-mentioned types of contracts entered into by the federal government that are subject to the Davis-Bacon Act itself, but it does not apply to contracts subject only to the Davis-Bacon Related Acts, including those set forth at 29 CFR 5.1(a)(2)-(60). Additional information on contractor requirements and worker protections under the EO is available at [www.dol.gov/whd/govcontracts](http://www.dol.gov/whd/govcontracts).

Modification Number	Publication Date
0	01/04/2019
1	01/11/2019
2	04/12/2019
3	06/07/2019

BRPA0009-039 12/01/2018

	Rates	Fringes
BRICKLAYER.....	\$ 32.35	22.21

-----  
 CARP0142-004 06/01/2018

	Rates	Fringes
CARPENTER (cluding Drywall Hanging and Asphalt Roofing).....	\$ 28.02	12.59

-----  
 CARP1759-007 06/01/2017

	Rates	Fringes
SOFT FLOOR LAYER.....	\$ 33.01	16.45

-----  
 ELEC0005-013 12/21/2018

	Rates	Fringes
ELECTRICIAN.....	\$ 24.34	15.53

-----  
 ELEV0006-004 01/01/2019

	Rates	Fringes
ELEVATOR MECHANIC.....	\$ 48.73	33.705+A+B

FOOTNOTE:

A. Employer contributes 8% of regular hourly rate as vacation pay credit for employees with more than 5 years of service, and 6% for 6 months to 5 years of service.

B. Eight Paid Holidays (provided employee has worked 5 consecutive days before and the working day after the holiday): New Years's Day; Memorial Day; Independence Day; Labor Day; Veteran's Day; Thanksgiving Day and the Friday after Thanksgiving Day, and Christmas Day.

-----

\* IRON0003-006 06/01/2019

	Rates	Fringes
IRONWORKER, ORNAMENTAL.....	\$ 35.49	31.84

-----

\* PLUM0027-005 06/01/2019

	Rates	Fringes
PLUMBER.....	\$ 42.30	22.47

-----

SHEE0012-006 07/01/2018

	Rates	Fringes
Sheet metal worker		
Excluding HVAC Duct Work....	\$ 19.49	10.08

-----

SUPA2003-001 10/31/2003

	Rates	Fringes
Drywall Finishers.....	\$ 15.08	3.40
Laborers, Unskilled.....	\$ 12.70	2.12
PAINTER (Brush and Roller).....	\$ 15.90	4.35
PLASTERER.....	\$ 18.20	5.16

Power equipment operators:

(Backhoe).....\$ 17.34                    4.06

Roofer (Excluding Asphalt

Roofing).....\$ 18.70                    5.19

Sheet Metal Worker (HVAC Duct

Only).....\$ 16.00                    3.08

-----  
WELDERS - Receive rate prescribed for craft performing  
operation to which welding is incidental.

=====  
Note: Executive Order (EO) 13706, Establishing Paid Sick Leave  
for Federal Contractors applies to all contracts subject to the  
Davis-Bacon Act for which the contract is awarded (and any  
solicitation was issued) on or after January 1, 2017. If this  
contract is covered by the EO, the contractor must provide  
employees with 1 hour of paid sick leave for every 30 hours  
they work, up to 56 hours of paid sick leave each year.  
Employees must be permitted to use paid sick leave for their  
own illness, injury or other health-related needs, including  
preventive care; to assist a family member (or person who is  
like family to the employee) who is ill, injured, or has other  
health-related needs, including preventive care; or for reasons  
resulting from, or to assist a family member (or person who is  
like family to the employee) who is a victim of, domestic  
violence, sexual assault, or stalking. Additional information  
on contractor requirements and worker protections under the EO  
is available at [www.dol.gov/whd/govcontracts](http://www.dol.gov/whd/govcontracts).

Unlisted classifications needed for work not included within  
the scope of the classifications listed may be added after  
award only as provided in the labor standards contract clauses  
(29CFR 5.5 (a) (1) (ii)).

-----

The body of each wage determination lists the classification and wage rates that have been found to be prevailing for the cited type(s) of construction in the area covered by the wage determination. The classifications are listed in alphabetical order of ""identifiers"" that indicate whether the particular rate is a union rate (current union negotiated rate for local), a survey rate (weighted average rate) or a union average rate (weighted union average rate).

#### Union Rate Identifiers

A four letter classification abbreviation identifier enclosed in dotted lines beginning with characters other than ""SU"" or ""UAVG"" denotes that the union classification and rate were prevailing for that classification in the survey. Example: PLUM0198-005 07/01/2014. PLUM is an abbreviation identifier of the union which prevailed in the survey for this classification, which in this example would be Plumbers. 0198 indicates the local union number or district council number where applicable, i.e., Plumbers Local 0198. The next number, 005 in the example, is an internal number used in processing the wage determination. 07/01/2014 is the effective date of the most current negotiated rate, which in this example is July 1, 2014.

Union prevailing wage rates are updated to reflect all rate changes in the collective bargaining agreement (CBA) governing this classification and rate.

#### Survey Rate Identifiers

Classifications listed under the ""SU"" identifier indicate that no one rate prevailed for this classification in the survey and the published rate is derived by computing a weighted average rate based on all the rates reported in the survey for that classification. As this weighted average rate includes all rates reported in the survey, it may include both union and non-union rates. Example: SULA2012-007 5/13/2014. SU indicates the rates are survey rates based on a weighted average

calculation of rates and are not majority rates. LA indicates the State of Louisiana. 2012 is the year of survey on which these classifications and rates are based. The next number, 007 in the example, is an internal number used in producing the wage determination. 5/13/2014 indicates the survey completion date for the classifications and rates under that identifier.

Survey wage rates are not updated and remain in effect until a new survey is conducted.

#### Union Average Rate Identifiers

Classification(s) listed under the UAVG identifier indicate that no single majority rate prevailed for those classifications; however, 100% of the data reported for the classifications was union data. EXAMPLE: UAVG-OH-0010 08/29/2014. UAVG indicates that the rate is a weighted union average rate. OH indicates the state. The next number, 0010 in the example, is an internal number used in producing the wage determination. 08/29/2014 indicates the survey completion date for the classifications and rates under that identifier.

A UAVG rate will be updated once a year, usually in January of each year, to reflect a weighted average of the current negotiated/CBA rate of the union locals from which the rate is based.

---

#### WAGE DETERMINATION APPEALS PROCESS

1.) Has there been an initial decision in the matter? This can be:

- \* an existing published wage determination
- \* a survey underlying a wage determination
- \* a Wage and Hour Division letter setting forth a position on a wage determination matter
- \* a conformance (additional classification and rate) ruling

On survey related matters, initial contact, including requests for summaries of surveys, should be with the Wage and Hour Regional Office for the area in which the survey was conducted because those Regional Offices have responsibility for the Davis-Bacon survey program. If the response from this initial contact is not satisfactory, then the process described in 2.) and 3.) should be followed.

With regard to any other matter not yet ripe for the formal process described here, initial contact should be with the Branch of Construction Wage Determinations. Write to:

Branch of Construction Wage Determinations  
Wage and Hour Division  
U.S. Department of Labor  
200 Constitution Avenue, N.W.  
Washington, DC 20210

2.) If the answer to the question in 1.) is yes, then an interested party (those affected by the action) can request review and reconsideration from the Wage and Hour Administrator (See 29 CFR Part 1.8 and 29 CFR Part 7). Write to:

Wage and Hour Administrator  
U.S. Department of Labor  
200 Constitution Avenue, N.W.  
Washington, DC 20210

The request should be accompanied by a full statement of the interested party's position and by any information (wage payment data, project description, area practice material, etc.) that the requestor considers relevant to the issue.

3.) If the decision of the Administrator is not favorable, an interested party may appeal directly to the Administrative Review Board (formerly the Wage Appeals Board). Write to:

Administrative Review Board  
U.S. Department of Labor  
200 Constitution Avenue, N.W.



Washington, DC 20210

4.) All decisions by the Administrative Review Board are final.

=====

END OF GENERAL DECISION"

# Building

"General Decision Number: PA20190001 07/05/2019

Superseded General Decision Number: PA20180001

State: Pennsylvania

Construction Type: Building

County: Allegheny County in Pennsylvania.

BUILDING ERECTION AND FOUNDATION EXCAVATION PROJECTS (does not include residential construction consisting of single family homes and apartmentns up to and including 4 stories) EXCLUDING SEWAGE AND TREATMENT PLANT PROJECTS

Note: Under Executive Order (EO) 13658, an hourly minimum wage of \$10.60 for calendar year 2019 applies to all contracts subject to the Davis-Bacon Act for which the contract is awarded (and any solicitation was issued) on or after January 1, 2015. If this contract is covered by the EO, the contractor must pay all workers in any classification listed on this wage determination at least \$10.60 per hour (or the applicable wage rate listed on this wage determination, if it is higher) for all hours spent performing on the contract in calendar year 2019. If this contract is covered by the EO and a classification considered necessary for performance of work on the contract does not appear on this wage determination, the contractor must pay workers in that classification at least the wage rate determined through the conformance process set forth in 29 CFR 5.5(a)(1)(ii) (or the EO minimum wage rate, if it is higher than the conformed wage rate). The EO minimum wage rate will be adjusted annually. Please note that this EO applies to the above-mentioned types of contracts entered into by the federal government that are subject to the Davis-Bacon Act itself, but it does not apply to contracts subject only to the Davis-Bacon Related Acts, including those set forth at 29 CFR 5.1(a)(2)-(60). Additional information on contractor

requirements and worker protections under the EO is available  
 at [www.dol.gov/whd/govcontracts](http://www.dol.gov/whd/govcontracts).

Modification Number	Publication Date
0	01/04/2019
1	01/11/2019
2	02/22/2019
3	06/07/2019
4	06/28/2019
5	07/05/2019

ASBE0002-001 08/01/2018

	Rates	Fringes
Asbestos Workers/Insulator		
Includes the application of all insulating materials, protective coverings, coatings and finishings to all types of mechanical systems.....	\$ 40.21	24.72

BOIL0154-001 01/01/2017

	Rates	Fringes
BOILERMAKER.....	\$ 40.90	27.27

BRPA0009-029 12/01/2018

	Rates	Fringes
BRICKLAYER.....	\$ 32.35	22.21

BRPA0009-060 06/01/2019

	Rates	Fringes
MASON - STONE.....	\$ 33.72	21.80

-----  
BRPA0009-061 12/01/2018

	Rates	Fringes
TILE SETTER.....	\$ 31.30	19.42

-----

CARP0142-001 06/01/2018

	Rates	Fringes
Carpenter/Lather.....	\$ 33.75	17.03

-----

CARP1759-001 06/01/2018

	Rates	Fringes
FLOOR LAYER: Carpet.....	\$ 33.75	17.03

-----

CARP2235-001 06/01/2018

	Rates	Fringes
MILLWRIGHT.....	\$ 40.34	19.16

-----

CARP2235-007 01/01/2019

	Rates	Fringes
PILEDRIVERMAN.....	\$ 34.30	19.30

-----

ELEC0005-007 12/21/2018

	Rates	Fringes
ELECTRICIAN.....	\$ 40.76	26.34

-----

ELEC0126-006 05/24/2019

	Rates	Fringes
--	-------	---------

LINE CONSTRUCTION

Cable Splicer.....	\$ 47.38	30.25%+11.50
Groundmen.....	\$ 28.43	30.25%+11.50
Lineman.....	\$ 47.38	30.25%+11.50
Truck Driver.....	\$ 30.80	30.25%+11.50
Winch Truck Operator.....	\$ 33.17	30.25%+11.50

-----  
 ELEV0006-001 01/01/2019

	Rates	Fringes
ELEVATOR MECHANIC.....	\$ 48.73	33.705+A+B

FOOTNOTE: A. Employer contributes 8% of regular hourly rate as vacation pay credit for employees with more than 5 years of service, and 6% for 6 months to 5 years of service.

B. Eight Paid Holidays (provided employee has worked 5 consecutive days before and the working day after the holiday): New Years's Day; Memorial Day; Independence Day; Labor Day; Veteran's Day; Thanksgiving Day and the Friday after Thanksgiving Day, and Christmas Day.

-----  
 \* ENGI0066-001 06/01/2019

	Rates	Fringes
Power equipment operators:		
CLASS 1.....	\$ 35.69	21.75
CLASS 2.....	\$ 30.22	21.75
CLASS 3.....	\$ 27.67	21.75

POWER EQUIPMENT OPERATORS CLASSIFICATIONS

CLASS I

Asphalt Paver, Asphalt Roller, Asphalt Plant Operator, Athey Loader, Auger (Truck or Tractor Mounted), Auto Grader (C.M.I. and similar), Backhoe (180' and 360' swing), Back-Filling Machine, Batch Plant, Bulldozer, Cable Layer, Cableway, Caisson Drill, Central Mix Plant, Compactor with

Blade, Concrete Pump (all types), Over-Head Crane, Crane (Crawler or Truck Mounted)\*, Tower Crane (Stationary or Climbing Type), Rough Terrain Crane\*\*, Wagon Crane, Crushing and/or Screening Plant, Derrick Traveler, Derrick (all types)(when assistance is needed it will be an oiler or apprentice), Derrick Boats, Dragline, Drill (Davey or similar), Dredge, Drill (Well and Core)(Truck or Skid Mounted), Elevator, Excavating Equipment (all other), Fork Lift (Lull or similar), Franki Pile Machine (or similar), Guard Post Driver, Gradall (all types), Grader, Elevating Grader, Equipment Greaser, Helicopter, Helicopter Hoist Operators, Front End Loader, Hoist, Hydraulic Boom Truck, Jumbo Operator, Kocal, Koehring Scooper, Locomotive, Metro Chip Harvester (or similar), Mix Mobile, Mixer - Paver, Mucking Machine, Multiple Bowl Machines, Pile Driver (Sonic or similar), Scrapers, Shovels (powered), Slip Form Paver (C.M.I. and similar), Spreader (Concrete, Asphalt, or Stone), Tire Repairman (when assigned to a jobsite), Tower Mobile, Tractors (all types), Trencher, Tug Boat, Vermeer Saw, Welder (repairman), Whirley

\* Cranes with Boom or Mast length (including jib) 100 ft or over shall be paid an additional \$.50 per hour for each 50-foot increment of additional boom and/or jib length)

\*\* Rough Terrain Cranes with Boom or Mast length (including jib) 101 ft or over shall be paid an Additional \$.50 per hour for each 50-foot increment of additional boom and/or jib length)

Note: An additional \$1.25 per hour (not counting boom pay) shall be paid for any crane (excluding overhead cranes) rated 100 ton or over.

## CLASS II

Ballast Regulator, Boat (material or personnel)(powered), Boiler, Boring Machine, Compressor (combined with Air Tugger, Air Pump, Gunit Machine, or Sand Blaster), Concrete Belt Placer, Concrete Saw, Conveyor, Carry Crane, Crushing/Screening Plants, Curb Builder (self-propelled), Forklifts (ridden or self-propelled), Form Line Machine, Generator (over 5KW), Grout Pump, Heaters, Hoist (monorail,

roof, one drum-regardless of power used), Huck Machine (or similar), Hydraulic Jack (single or multiple)(power driven), Ladavator, Mortar Mixer, Mulching Machine, Pavement Breaker (self-propelled or ridden), Pin Puller (powered), Pipe Cleaning Machine, Pipe Dream, Power Broom (except push type), Pulverizer, Pumps (regardless of power used), Roller/Compactor (Dirt), Refrigeration Plant, Ross Carrier (or similar), Seeding Machine, Skid Steer Loader (or similar), Slab Lifting Machine (hydraulic), Soil Stabilizer (pump type), Spray Cure Machine (power driven), Side Delivery Shoulder Spreader (attachment), Steam Jenny (or similar), Stone Crusher, Stone Spreader (self-propelled), Siphon (steam or air), Tie Tamper (multiple heads), Tractor (when used for landscaping, snaking, or hauling), Truck (Winch)(when hoisting and placing), Tube Finisher (C.M.I. and similar), Tugger, Water Blaster, Welding Machine, Well Point System

CLASS III

Brakeman, Deck Hand, Helicopter Signalman, Oiler\*, Elevator (Alterations & Remodeling Commercial Buildings),

\* Oilers on Truck Cranes: less than 50 ton shall receive \$.10 over the Class III base rate; 50 ton up to 100 ton rated capacity shall be paid an additional \$.25 per hour over the Class III base rate; 100 ton and over shall be paid an additional \$1.00 per hour over the Class III base rate.

General Note: Hazardous Material Sites Level C & D receive \$1.00 per hour premium for all classifications and Levels A & B receive \$2.50 premium for all classifications

-----  
 IRON0003-002 06/01/2019

	Rates	Fringes
IRONWORKER.....	\$ 35.49	31.84

-----  
 LAB00613-002 01/01/2019



	Rates	Fringes
Laborers:		
GROUP 1.....	\$ 22.37	17.60
GROUP 2.....	\$ 22.52	17.60
GROUP 3.....	\$ 22.65	17.60
GROUP 4.....	\$ 23.12	17.60

LABORERS CLASSIFICATIONS

GROUP 1: COMMON LABORER - Building laborer; Brick removal for alterations; Carryable pumps; West brick buggy or similar; Walk behind forklift or similar (non self-propelled); Stripper and mover of forms; Toolroom man; all material conveyors (regardless of power used, including starting and stopping); Pouring of mortar or aggregate into blocks of voids

GROUP 2: SKILLED LABORER - West brick buggy or similar (self propelled); Power wheelbarrows and buggies; walk behind forklift or similar (self-propelled); Drill runner; All operators of compacting equipment; Pipe layer; Burner; Jackhammer man - concrete buster; Vibrator operator; Clay spade and/or similar; Gunnite nozzleman; Blaster; Concrete saw operator; Hod carrier; Scaffold builder; Air track operator; Bell and Bottom Man on furnace and stacks; Grout machine feeder and pump operator; Gunnite machine operator or similar; Gunnite machine potman or similar; Mortar Mixer; Mortar mixer machine (regardless of power used, including starting and stopping); Wagon drill operator; Laser cleaner; Lancer

GROUP 3: Asbestos removal or abatement laborer

GROUP 4: Toxic or Hazardous waste handling laborer

-----  
LAB00952-004 01/01/2019

Rates Fringes

Landscaping

GROUP 1.....	\$ 21.02	16.08
GROUP 2.....	\$ 21.44	16.08
GROUP 3.....	\$ 21.74	16.08

LANDSCAPING CLASSIFICATIONS

GROUP 1: Landscape laborer to include general landscaping work and the driving of trucks for the distribution of materials on the job site but not to include trucks used to transport supplies to the job

GROUP 2: Skilled Landscape Laborer to plant all types of trees and shrubs without direct supervision.

GROUP 3 - Landscape tractor operator to operate small industrial rubber tire tractor equipped with front end loader and backhoe attachment or a skid loader with landscape attachments used for the sole purpose of landscape work including soil spreading, unloading and loading of materials and such other landscaping work but not for heavy and highway construction work

-----  
\* PAIN057-003 06/01/2019

Rates Fringes

PAINTER

Brush & Roller.....	\$ 28.50	19.82
---------------------	----------	-------

-----  
\* PAIN057-005 06/01/2019

Rates Fringes

DRYWALL FINISHER/TAPER.....	\$ 29.10	20.10
-----------------------------	----------	-------

-----  
PAIN0751-001 09/01/2018

Rates Fringes



SHEET METAL WORKER.....\$ 34.47                    27.54

-----  
TEAM0040-002 01/01/2017

	Rates	Fringes
Truck drivers:		
GROUP 1.....	\$ 28.10	17.42
GROUP 2.....	\$ 28.24	17.50
GROUP 3.....	\$ 28.71	17.80

FOOTNOTES:

A. Hazardous/toxic waste material/work level A & B receive additional \$2.50 per hour above classification rate

B. Hazardous/toxic waste materials/Work level C & D receive \$1.00 per hour above classification

TRUCK DRIVERS CLASSIFICATIONS

GROUP 1 - Single Axle (2 axles including steering axle);  
Includes partsman and warehoueman

GROUP 2 - Tandem - Tri-Axle - Semi-Tractor Trailer  
(combination) (3 axles or more including steering axle)

GROUP 3 - Specialty Vehicles; Heavy equipment whose capacity exceeds that for which state licenses are issued specifically refers to units in excess of eight (8) feet width (such as Euclids, Atley Wagon, Payloader, Tournawagons, and similar equipment when not self loaded); Tar and Asphalt Distributors Trucks, Heavy Duty Trailer, such as Low Boy, High Boy

-----  
WELDERS - Receive rate prescribed for craft performing operation to which welding is incidental.

=====

Note: Executive Order (EO) 13706, Establishing Paid Sick Leave for Federal Contractors applies to all contracts subject to the Davis-Bacon Act for which the contract is awarded (and any solicitation was issued) on or after January 1, 2017. If this contract is covered by the EO, the contractor must provide employees with 1 hour of paid sick leave for every 30 hours they work, up to 56 hours of paid sick leave each year. Employees must be permitted to use paid sick leave for their own illness, injury or other health-related needs, including preventive care; to assist a family member (or person who is like family to the employee) who is ill, injured, or has other health-related needs, including preventive care; or for reasons resulting from, or to assist a family member (or person who is like family to the employee) who is a victim of, domestic violence, sexual assault, or stalking. Additional information on contractor requirements and worker protections under the EO is available at [www.dol.gov/whd/govcontracts](http://www.dol.gov/whd/govcontracts).

Unlisted classifications needed for work not included within the scope of the classifications listed may be added after award only as provided in the labor standards contract clauses (29CFR 5.5 (a) (1) (ii)).

-----

The body of each wage determination lists the classification and wage rates that have been found to be prevailing for the cited type(s) of construction in the area covered by the wage determination. The classifications are listed in alphabetical order of "identifiers" that indicate whether the particular rate is a union rate (current union negotiated rate for local), a survey rate (weighted average rate) or a union average rate (weighted union average rate).

Union Rate Identifiers

A four letter classification abbreviation identifier enclosed

in dotted lines beginning with characters other than "SU" or "UAVG" denotes that the union classification and rate were prevailing for that classification in the survey. Example: PLUM0198-005 07/01/2014. PLUM is an abbreviation identifier of the union which prevailed in the survey for this classification, which in this example would be Plumbers. 0198 indicates the local union number or district council number where applicable, i.e., Plumbers Local 0198. The next number, 005 in the example, is an internal number used in processing the wage determination. 07/01/2014 is the effective date of the most current negotiated rate, which in this example is July 1, 2014.

Union prevailing wage rates are updated to reflect all rate changes in the collective bargaining agreement (CBA) governing this classification and rate.

#### Survey Rate Identifiers

Classifications listed under the "SU" identifier indicate that no one rate prevailed for this classification in the survey and the published rate is derived by computing a weighted average rate based on all the rates reported in the survey for that classification. As this weighted average rate includes all rates reported in the survey, it may include both union and non-union rates. Example: SULA2012-007 5/13/2014. SU indicates the rates are survey rates based on a weighted average calculation of rates and are not majority rates. LA indicates the State of Louisiana. 2012 is the year of survey on which these classifications and rates are based. The next number, 007 in the example, is an internal number used in producing the wage determination. 5/13/2014 indicates the survey completion date for the classifications and rates under that identifier.

Survey wage rates are not updated and remain in effect until a new survey is conducted.

#### Union Average Rate Identifiers

Classification(s) listed under the UAVG identifier indicate that no single majority rate prevailed for those

classifications; however, 100% of the data reported for the classifications was union data. EXAMPLE: UAVG-OH-0010 08/29/2014. UAVG indicates that the rate is a weighted union average rate. OH indicates the state. The next number, 0010 in the example, is an internal number used in producing the wage determination. 08/29/2014 indicates the survey completion date for the classifications and rates under that identifier.

A UAVG rate will be updated once a year, usually in January of each year, to reflect a weighted average of the current negotiated/CBA rate of the union locals from which the rate is based.

---

#### WAGE DETERMINATION APPEALS PROCESS

1.) Has there been an initial decision in the matter? This can be:

- \* an existing published wage determination
- \* a survey underlying a wage determination
- \* a Wage and Hour Division letter setting forth a position on a wage determination matter
- \* a conformance (additional classification and rate) ruling

On survey related matters, initial contact, including requests for summaries of surveys, should be with the Wage and Hour Regional Office for the area in which the survey was conducted because those Regional Offices have responsibility for the Davis-Bacon survey program. If the response from this initial contact is not satisfactory, then the process described in 2.) and 3.) should be followed.

With regard to any other matter not yet ripe for the formal process described here, initial contact should be with the Branch of Construction Wage Determinations. Write to:

Branch of Construction Wage Determinations

Wage and Hour Division  
U.S. Department of Labor  
200 Constitution Avenue, N.W.  
Washington, DC 20210

2.) If the answer to the question in 1.) is yes, then an interested party (those affected by the action) can request review and reconsideration from the Wage and Hour Administrator (See 29 CFR Part 1.8 and 29 CFR Part 7). Write to:

Wage and Hour Administrator  
U.S. Department of Labor  
200 Constitution Avenue, N.W.  
Washington, DC 20210

The request should be accompanied by a full statement of the interested party's position and by any information (wage payment data, project description, area practice material, etc.) that the requestor considers relevant to the issue.

3.) If the decision of the Administrator is not favorable, an interested party may appeal directly to the Administrative Review Board (formerly the Wage Appeals Board). Write to:

Administrative Review Board  
U.S. Department of Labor  
200 Constitution Avenue, N.W.  
Washington, DC 20210

4.) All decisions by the Administrative Review Board are final.

=====

END OF GENERAL DECISION"



# **Heavy & Highway**

"General Decision Number: PA20190002 07/05/2019

Superseded General Decision Number: PA20180004

State: Pennsylvania

Construction Types: Heavy and Highway

Counties: Allegheny, Armstrong, Beaver, Bedford, Blair, Butler, Cambria, Cameron, Centre, Clarion, Clearfield, Clinton, Crawford, Elk, Erie, Fayette, Forest, Franklin, Fulton, Greene, Huntingdon, Indiana, Jefferson, Lawrence, McKean, Mercer, Mifflin, Potter, Somerset, Venango, Warren, Washington and Westmoreland Counties in Pennsylvania.

HEAVY AND HIGHWAY CONSTRUCTION PROJECTS (excluding sewer grouting projects and excluding sewage and water treatment plant projects)

Note: Under Executive Order (EO) 13658, an hourly minimum wage of \$10.60 for calendar year 2019 applies to all contracts subject to the Davis-Bacon Act for which the contract is awarded (and any solicitation was issued) on or after January 1, 2015. If this contract is covered by the EO, the contractor must pay all workers in any classification listed on this wage determination at least \$10.60 per hour (or the applicable wage rate listed on this wage determination, if it is higher) for all hours spent performing on the contract in calendar year 2019. If this contract is covered by the EO and a classification considered necessary for performance of work on the contract does not appear on this wage determination, the contractor must pay workers in that classification at least the wage rate determined through the conformance process set forth in 29 CFR 5.5(a)(1)(ii) (or the EO minimum wage rate, if it is higher than the conformed wage rate). The EO minimum wage rate will be adjusted annually. Please note that this EO applies to

the above-mentioned types of contracts entered into by the federal government that are subject to the Davis-Bacon Act itself, but it does not apply to contracts subject only to the Davis-Bacon Related Acts, including those set forth at 29 CFR 5.1(a)(2)-(60). Additional information on contractor requirements and worker protections under the EO is available at [www.dol.gov/whd/govcontracts](http://www.dol.gov/whd/govcontracts).

Modification Number	Publication Date
0	01/04/2019
1	01/11/2019
2	02/15/2019
3	05/17/2019
4	06/07/2019
5	06/14/2019
6	07/05/2019

BOIL0013-005 03/01/2018

CENTRE, FRANKLIN, POTTER, CLINTON, FULTON, HUNTINDON AND MIFFLIN COUNTIES

	Rates	Fringes
BOILERMAKER.....	\$ 45.89	33.39

---

BOIL0154-004 01/01/2017

ALLEGHENY, ARMSTRONG, BEAVER, BEDFORD, BLAIR, BUTLER, CAMBRIA, CAMERON, CLARION, CLEARFIELD, CRAWFORD, ELK, FAYETTE, FOREST, GREENE, INDIANA, JEFFERSON, LAWRENCE, MCKEAN, MERCER, SOMERSET, VENANGO, WARREN, WASHINGTON AND WESTMORELAND COUNTIES

	Rates	Fringes
BOILERMAKER.....	\$ 40.90	27.27

---

BOIL0744-003 07/01/2008

ERIE COUNTY

	Rates	Fringes
BOILERMAKER.....	\$ 35.34	18.48

-----  
BRPA0005-033 05/01/2018

MIFFLIN COUNTY

	Rates	Fringes
Bricklayer, Stonemason.....	\$ 31.36	17.73

-----  
BRPA0005-046 05/01/2016

FRANKLIN COUNTY

	Rates	Fringes
Bricklayer, Stonemason.....	\$ 32.21	14.18

-----  
BRPA0005-071 05/01/2018

CLINTON COUNTY

	Rates	Fringes
BRICKLAYER.....	\$ 33.16	16.31

-----  
BRPA0009-004 12/01/2018

BEDFORD, BLAIR, CAMBRIA, CENTRE COUNTY (Halfmoon, Houston, Patton, Rush, Taylor and Worth Townships), FULTON, HUNTINGDON, and SOMERSET COUNTIES

	Rates	Fringes
--	-------	---------

Bricklayer, Stonemason &

Marble Setter.....\$ 29.46                   19.58

-----  
BRPA0009-006 12/01/2018

CLEARFIELD, FOREST, JEFFERSON, VENANGO, AND CLARION (Except  
Brady, Madison, Perry, Porter, Redbank, and Toby Townships)  
COUNTIES

	Rates	Fringes
Bricklayer, Stonemason.....	\$ 29.90	19.91
Marble mason.....	\$ 29.90	19.91

-----  
BRPA0009-023 06/01/2018

BEAVER COUNTY

	Rates	Fringes
BRICKLAYER.....	\$ 30.16	21.41

-----  
BRPA0009-025 12/01/2018

BUTLER, LAWRENCE, AND MERCER COUNTIES

	Rates	Fringes
BRICKLAYER.....	\$ 30.11	21.64

-----  
BRPA0009-032 06/01/2017

FAYETTE (Jefferson & Washington Twps), GREENE (Except  
Cumberland, Dunkirk, Greene, Monongahelia Twps), INDIANA, AND  
WESTMORELAND (Rostraver Twp) COUNTIES

	Rates	Fringes
BRICKLAYER.....	\$ 31.00	20.66

BRPA0009-033 12/01/2018

ARMSTRONG, CLARION (Brady, Madison, Perry, Tobe, Porter, Redbank Twps), FAYETTE (Except Jefferson & Washington Twps), GREENE (Cumberland, Dunkirk, Greene, Monongahelia Twps), INDIANA, AND WESTMORELAND (Except Rostrave Twp) COUNTIES

	Rates	Fringes
BRICKLAYER.....	\$ 31.95	21.96

-----  
BRPA0009-034 11/01/2017

ERIE COUNTY

	Rates	Fringes
BRICKLAYER.....	\$ 27.55	19.76

-----  
BRPA0009-058 12/01/2017

ALLEGHENY, WASHINGTON (Cross Creek, Hanover, Jefferson, Mt Pleasant, Nottingham, Peters, Robinson, Smith, Union Twps) COUNTIES

	Rates	Fringes
BRICKLAYER.....	\$ 31.69	21.27

-----  
BRPA0009-059 12/01/2018

CAMERON, ELK, MCKEAN, POTTER AND WARREN COUNTIES

	Rates	Fringes
BRICKLAYER.....	\$ 27.66	19.67

-----  
CARP2235-005 01/01/2019

Rates Fringes

PILEDRIVERMAN

Piledriverman (welder).....	\$ 35.25	19.30
Piledriverman.....	\$ 34.30	19.30

-----  
CARP2235-006 01/01/2019

Rates Fringes

Diver.....	\$ 51.45	19.30
Tender.....	\$ 34.30	19.30

-----  
CARP2274-001 01/01/2019

Rates Fringes

CARPENTER (ALLEGHENY,  
ARMSTRONG, BEAVER, BUTLER,  
ERIE, FAYETTE, GREENE,  
LAWRENCE, MERCER, WASHINGTON,  
AND WESTMORELAND COUNTIES)

Carpenters (Welders).....	\$ 34.97	18.42
Carpenters.....	\$ 34.02	18.42

CARPENTER (BEDFORD, BLAIR,  
CAMBRIA, CAMERON, CENTRE,  
CLARION, CLINTON, CLEARFIELD,  
CRAWFORD, ELK, FOREST,  
FRANKLIN, FULTON, HUNTINGDON,  
INDIANA, JEFFERSON, MCKEAN,  
MIFFLIN, POTTER, SOMERSET,  
VENANGO, AND WARREN COUNTIES)

Carpenters (Welders).....	\$ 34.72	18.42
Carpenters.....	\$ 33.77	18.42

-----  
ELEC0005-006 12/21/2018

ALLEGHENY, ARMSTRONG, BEDFORD, BLAIR, BUTLER CAMBRIA, CAMERON,  
CENTRE (Remainder), CLARION, CLEARFIELD, ELK, FAYETTE, FULTON,  
GREENE, HUNTINGDON, INDIANA, JEFFERSON, MCKEAN, SOMERSET,  
VENANGO, WASHINGTON, AND WESTMORELAND COUNTIES

Rates Fringes

ELECTRICIAN.....\$ 40.76 26.34

ELEC0056-004 06/03/2019

ERIE, FOREST AND WARREN COUNTIES

Rates Fringes

ELECTRICIAN.....\$ 34.34 22.27

ELEC0126-005 05/24/2019

ALLEGHENY, ARMSTRONG, BEAVER, BEDFORD, BLAIR, CAMBRIA, CENTRE, CLARION, CLEARFIELD, FAYETTE, FULTON, GREENE, HUNTINGDON, INDIANA, JEFFERSON, SOMERSET, WASHINGTON AND WESTMORELAND

Rates Fringes

Line Construction:

Cable Splicer.....\$ 47.38 30.25%+11.50
Groundman.....\$ 28.43 30.25%+11.50
Lineman.....\$ 47.38 30.25%+11.50
Truck Driver.....\$ 30.80 30.25%+11.50
Winch Truck Operator.....\$ 33.17 30.25%+11.50

ELEC0126-007 05/28/2018

FRANKLIN AND MIFFLIN COUNTIES

Rates Fringes

Line Construction:

Cable Splicer.....\$ 45.25 29.25%+11.25
Groundman.....\$ 27.15 29.25%+11.25
Lineman.....\$ 45.25 29.25%+11.25
Truck Driver.....\$ 29.41 29.25%+11.25



Winch Truck Operator.....\$ 31.68 29.25%+11.25

-----  
ELEC0143-007 06/01/2019

FRANKLIN and MIFFLIN COUNTIES

	Rates	Fringes
ELECTRICIAN.....	\$ 31.60	24.07

-----  
ELEC0712-003 12/31/2018

CRAWFORD, BEAVER, LAWRENCE AND MERCER COUNTIES

	Rates	Fringes
ELECTRICIAN.....	\$ 38.55	23.49

-----  
ELEC0812-008 06/01/2017

CLINTON COUNTY

	Rates	Fringes
ELECTRICIAN.....	\$ 33.59	18.61

-----  
ELEC0812-009 06/01/2017

POTTER COUNTY

	Rates	Fringes
ELECTRICIAN.....	\$ 34.60	18.64

-----  
ELEC0812-011 06/01/2017

CENTRE COUNTY (Burnside, Curtin, Liberty, Howard, Marion,  
Walker, Miles, Haines Townships)

	Rates	Fringes
--	-------	---------

ELECTRICIAN.....\$ 33.59 18.61

-----  
ELEC1319-004 09/02/2018

BUTLER, CAMERON, CLINTON, CRAWFORD, ELK, ERIE, FOREST,  
LAWRENCE, MCKEAN, MERCER, VENANGO, WARREN AND POTTER COUNTIES

Rates Fringes

Line Construction:

Equipment Operator.....\$ 56.43 19.84  
Groundmen.....\$ 34.99 11.28  
Linemen.....\$ 56.43 22.84  
Truck Driver.....\$ 36.68 11.41

-----  
ENGI0066-016 01/01/2019

Rates Fringes

Power equipment operators:

(ALLEGHENY, ARMSTRONG,  
BEAVER, BLAIR, BUTLER,  
CAMBRIA, CENTRE, CLARION,  
CLEARFIELD, CRAWFORD, ERIE,  
ELK, FAYETTE, GREENE,  
INDIANA, JEFFERSON, LAWRENCE,  
MCKEAN, MERCER, SOMERSET,  
VENANGO, WARREN, WASHINGTON,  
AND WESTMORELAND COUNTIES)

GROUP 1.....\$ 31.89 21.68  
GROUP 2.....\$ 31.63 21.68  
GROUP 3.....\$ 27.98 21.68  
GROUP 4.....\$ 27.52 21.68  
GROUP 5.....\$ 27.27 21.68

Power equipment operators:

(BEDFORD, CAMERON, CLINTON,  
FOREST, FRANKLIN, FULTON,  
HUNTINGDON, MIFFLIN, AND  
POTTER COUNTIES)

GROUP 1.....	\$ 31.60	21.68
GROUP 2.....	\$ 31.32	21.68
GROUP 3.....	\$ 27.68	21.68
GROUP 4.....	\$ 27.19	21.68
GROUP 5.....	\$ 26.98	21.68

POWER EQUIPMENT OPERATORS CLASSIFICATIONS

GROUP 1 - Asphalt Paving Machine (Spreader), Autograde (C.M.I. and similar); Backfiller, Compactor with Blade, Backhoe - 360 and 180 degree Swing; Cableway; Caisson Drill (similar to Hugh Williams), Central Mix Plant; Cooling Plant; Concrete Paving Mixer, Concrete Pump (self-propelled); Cranes; Cranes (boom or mast over 101ft.\$50 per each additional 50 feet inclusive of jib), Cranes (Tower Stationary- Climbing Tower Crane); Derrick; Derrick Boat; Dozer(greater than 25,000 lbs.); Dragline; Dredge; Dredge Hydraulic; Elevating Grader; Franki Pile Machine; Gradall (remote control or otherwise),Grader (power-fine grade); Hllift (4 cy. and over); Hoist 2 Drums or more (in one unit); Hydraulic Boom Truck with pivotal cab (single motor-Pitman or similar), (Boom and Mast over 101 feet will be paid an additional 50 feet inclusive of jib if used;) Kocal; Mechanic, Locomotive (std. Gauge); Metro-chip Harvester or similar; Milling Machine (Roto Mill or similar); Mix Mobile; Mix Mobile (with Self Loading Attachment), Mucking Machine (tunnel); Pile Driver Machine; Pipe Extrusion Machine; Presplitter Drill (self contained); Refrigeration Plant (soil Stablization) Rough Terrain Crane (25 ton over) (Boom and Mast over 101 feet will be paid an additional 50 feet inclusive of jib if used); Rough Terrain Crane (under 25 ton), Scrapers; Shovel-Power; Slip form Paver (C.M.I. and similar); Trenching Machine (30,000 lbs. and over), Trenching Machine (under 30,000 lb.), Tunnell Machine (Mark XXI Jarva or similar), Vermeer Saw, Whirley, Mechanic, Compactor with blade

GROUP 2: Asphalt plant operator; auger (tractor mtd.); auger (truck mtd.); belt loader (euclid or similar); boring machine; cable placer or layer; Directional drill over 3,000 lbs thrust; concrete batch plant (electronically

synchronized); concrete belt placer (C.M.I. and similar); concrete finishing machine and spreader, concrete mixer (over 1 cy.) concrete pump (stationary); core drill (truck or skid mtd. - similar to penn drill), dozer (25,000 lbs or less); Ditch Witch Saw, force feed loader; fork lift (lull or similar); grader - power; grease unit operator (head); guard rail post driver (truck mounted) guard rail post driver (skid type); hiliift (under 4 cy.); skid steer loader; hydraulic boom truck (non-pivotal cab); job work boat (powered), jumbo operator; locomotive (narrow guage); minor equipment operator (accumulative four units); mucking machine; multi-head saw (groover); overhead crane; roller -power- asphalt; ross carrier; side boom or tractor mounted boom; shuttle buggy (asphalt), stone crusher (screening-washing plants); stone spreader (self propelled) truck mounted drill (davey or similar); welder and repairman; well point pump operator; bidwell concrete finishing machine (or similar).

GROUP 3: Broom Finisher (C.M.I. or similar); Compactors/Rollers (static or vibratory (Self-propelled) on dirt or stone; Curb Builder; Minor Equipment Operator (two or three units); Multi-head Tie Tamper; Pavement Breaker (self-propelled or ridden); Soil Stabilizer Machine; Tire Repairman; Tractor (snaking and hauling); Well Driller and Horizontal; Winch or "A" Frame Truck (when hoisting and lowering).

GROUP 4: Ballast Regulator; Compressor; Concrete Mixer (1 cy. & under with skip); Concrete Saw (Ridden or self-propelled); Conveyor; Elevator (Material hauling only); Fork-lift (Ridden or self-propelled); Form Line Machine; Generator; Groute Pump; Heater (Machinical); Hoist (single Drum); Ladavator, Light Plant; Mulching Machine; Personnel Boat (Powered), Pulverizer, Pumps, Seeding Machine, spray Cure Machine (powered Driven); Subgrader; Tie Puller; Tugger; Welding Machine (Gas or Diesel).

GROUP 5: Deck Hand; Farm Tractor; Fireman on Boiler; Oiler; Power Broom; Side Delivery Shoulder Spreader (attachment);

-----  
IRON0003-001 06/01/2019

ALLEGHENY, FAYETTE, WESTMORELAND, CAMBRIA, INDIANA, ARMSTRONG,  
BUTLER, BEAVER, CLARION, AND WASHINGTON COUNTIES

	Rates	Fringes
IRONWORKER.....	\$ 35.49	31.84

-----

IRON0003-007 06/01/2019

BLAIR, CAMERON, CENTRE, CLEARFIELD, CLINTON, ELK, JEFFERSON,  
MCKEAN, AND POTTER COUNTIES

	Rates	Fringes
IRONWORKER.....	\$ 29.58	29.92

-----

IRON0003-011 06/01/2019

CRAWFORD, ERIE, FOREST, AND WARREN COUNTIES

	Rates	Fringes
IRONWORKER.....	\$ 30.75	29.70

-----

IRON0207-002 06/01/2018

LAWRENCE, MERCER, AND VENANGO COUNTIES

	Rates	Fringes
IRONWORKER.....	\$ 28.92	24.90

-----

\* IRON0404-008 07/01/2019

FRANKLIN (Remainder), HUNTINGDON (Remainder), AND MIFFLIN  
COUNTIES

	Rates	Fringes
IRONWORKER, STRUCTURAL.....	\$ 32.76	29.88

-----  
 IRON0549-002 12/01/2012

GREENE COUNTY

	Rates	Fringes
IRONWORKER.....	\$ 30.45	16.04

-----  
 IRON0568-004 05/01/2018

BEDFORD, FRANKLIN (Southwest 1/3), FULTON, HUNTINGDON (Western  
 2/3), AND SOMERSET COUNTIES

	Rates	Fringes
IRONWORKER Structural, Ornamental, Reinforcing, Machinery Mover, Rigger & Machinery Erector, Welder, Fence Erector.....	\$ 28.56	20.61

-----  
 LAB01058-001 01/01/2019

	Rates	Fringes
LABORER (BEDFORD, CAMERON, CENTRE, CLINTON, CRAWFORD, FOREST, FRANKLIN, FULTON, HUNTINGDON, JEFFERSON, MIFFLIN, AND POTTER COUNTIES)		
GROUP 1.....	\$ 25.35	23.25
GROUP 2.....	\$ 25.51	23.25
GROUP 3.....	\$ 26.00	23.25

GROUP 4.....	\$ 26.45	23.25
GROUP 5.....	\$ 26.86	23.25
GROUP 6.....	\$ 23.70	23.25
GROUP 7.....	\$ 26.35	23.25
GROUP 8.....	\$ 27.85	23.25

Laborers: (ALLEGHENY,  
 ARMSTRONG, BEAVER, BLAIR,  
 BUTLER, CAMBRIA, CLARION,  
 CLEARFIELD, ELK, ERIE,  
 FAYETTE, GREENE, INDIANA,  
 LAWRENCE, MCKEAN, MERCER,  
 SOMERSET, VENANGO, WARREN,  
 WASHINGTON, AND WESTMORELAND  
 COUNTIES)

GROUP 1.....	\$ 25.45	23.25
GROUP 2.....	\$ 25.61	23.25
GROUP 3.....	\$ 26.00	23.25
GROUP 4.....	\$ 26.45	23.25
GROUP 5.....	\$ 26.86	23.25
GROUP 6.....	\$ 23.70	23.25
GROUP 7.....	\$ 26.45	23.25
GROUP 8.....	\$ 27.95	23.25

LABORERS CLASSIFICATIONS

GROUP 1: Asphalt curb sealer; Asphalt tamper; Batcherman  
 (weigh) Blaster, Boatman, Brakeman, Change house attendant,  
 Cofferdam, Concrete curing pitman, Puddler, Drill Runner's  
 helper (Includes Drill Mounted on Truck, Track, or similar  
 and Davey Drill Spots, Clean up, helps to maintain),  
 Electric Brush and or Grinder, Fence Construction  
 (Including Fence Machine Operator) Form stripper and Mover,  
 Gabion (Erectors and Placers) Hydro jet blaster nozzleman;  
 Landscape laborer, Manually moved emulsion sprayer, Radio  
 actuated traffic control operator Rip rap work, scaffolds  
 and Runways, Sheeters and Shorers (includes lagging)  
 structural concrete Top Surfacers, Walk Behind Street  
 Sweeper, and Wood Chipper; water boy

GROUP 2: Air tool operator (all types); Asphalt, batch &  
 concrete plant operator (manually operated) Burner,

Caisson; men (open air); Carryable pumps; Chain saw operator including attachments, Cribbing, (concrete or steel); Curb machine operator (asphalt or concrete walk behind); Diamond head Core Driller, Drill runner's helper (tunnel) Fork Lift, (walk behind), Form Setter (Road Forms Line man) Highway Slab reinforcement placers (including joint and Basket Setters) Hydraulic pipe pusher; Liner plates (Tile or Vitrified Clay) Mechanical compacting equipment operators, Mechanical joint sealer, Dope pot and Tar Kettle, Mortar mixer (hand or machine) Muckers, Brakemen & all other Labor, (Includes installation of utility lines) Pipe Layers /Fusion /Heating Iron (Regardless of materials) Portable Single Unit Conveyor, Post Hole Auger, (2 or 4 cycle hand operated) Power wheelbarrows and buggies, Rail porter or similar; Sand blaster;Signal Man,Vibrator operator, All RAILROAD TRACK WORK TO INCLUDE THE FOLLOWING: adzing machine, ballast Router, Bolting Machine, Power Jacks, Rail Drills, Railroad Brakeman,Rail Saws, Spike Drivers (Manually or hand held tool) Spike Pullers Tamping Machine, Thermitweld

GROUP 3: Asphalt Luteman/Raker,Blacksmith, Blaster, Brick, stone and block pavers and block cutters (wood, belgian and asphalt); Cement mortar lining car pusher; Cement mortar mixer (pipe relining); Cement mortar pipe reliners; concrete saw operator (walk behind); Curb cutters and setters; Elevated roadway drainage construction; erector of overhead signs, Form setter (road forms-lead man); Grout machine operator; Gunite or dry pack gun (nozzle and machine man); Manhole or catch basin builder (Brick block concrete or any prefabrication) Miners and drillers (including lining, supporting and form workmen, setting of shields, miscellaneous equipment and jumbos); Multi-plate pipe (aligning and securing); Placing wire mesh on gunite projects; Wagon drill operators (air track or similar); Walk behind ditching machine (trencher or similar);crown screed adjuster and welder

GROUP 4: Reinforcing Steel Placer (Bending, aligning, and securing, Cadweld)



GROUP 5:High Burner, (Any burning not done from deck), Welder  
(Pipeline)

GROUP 6: Uniformed Flagperson, Watchman

GROUP 7: Toxic/Hazardous Waste Removal Laborer Levels C & D

GROUP 8: Toxic/Hazardous Waste Removal Laborer Levels A & B

-----  
PAIN0021-019 05/01/2018

CLINTON COUNTY

	Rates	Fringes
Painters:		
Bridge.....	\$ 36.67	18.80
Brush & Roller.....	\$ 27.67	18.80
Spray.....	\$ 28.67	18.80

-----  
PAIN0021-024 05/01/2018

FRANKLIN COUNTY

	Rates	Fringes
PAINTER		
Brush.....	\$ 23.92	14.23

-----  
\* PAIN0057-014 06/01/2019

ALLEGHENY, FAYETTE, GREENE, WASHINGTON COUNTIES

	Rates	Fringes
Painters:		
Bridge.....	\$ 35.25	19.82
Brush & Roller.....	\$ 28.50	19.82
Spray.....	\$ 28.50	19.82

-----

\* PAIN0057-015 06/01/2019

ARMSTRONG, BEAVER, BEDFORD, BLAIR, BUTLER, CAMBRIA, CENTRE,  
CLARION, CLEARFIELD, ELK, FULTON, HUNTINGTON, INDIANA,  
JEFFERSON, LAWRENCE, MERCER, MIFFLIN, SOMERSET, VENANGO AND  
WESTMORELAND COUNTIES

	Rates	Fringes
Painters:		
Bridge.....	\$ 35.25	19.82
Brush and Roller.....	\$ 28.50	19.82
Spray.....	\$ 28.50	19.82

-----  
PAIN0057-022 05/01/2019

	Rates	Fringes
Painters: (ERIE, MCKEAN, AND WARREN (Including Columbus and Freehold twps) COUNTIES)		
Bridges, Stacks, Towers.....	\$ 25.37	18.71
Brush and Roller.....	\$ 22.87	18.71
Spray and Sandblasting.....	\$ 23.62	18.71

-----  
\* PAIN0057-027 06/01/2019

CAMERON, CRAWFORD, POTTER, WARREN, (Excluding Columbus and  
Freehold twps)

	Rates	Fringes
PAINTER		
Brush and Roller.....	\$ 25.11	19.14

-----  
PLAS0526-002 01/01/2019

	Rates	Fringes
--	-------	---------

CEMENT MASON/CONCRETE FINISHER...\$ 31.94 20.50

-----  
PLUM0027-001 06/01/2019

ALLEGHENY, ARMSTRONG, GREENE (Except extreme Eastern portion),  
WASHINGTON (Except extreme Eastern portion) and WESTMORELAND  
(City of Arnold and City of New Kensington Only) COUNTIES

Rates Fringes

Plumbers and Pipefitters  
(Bridge Drain Pipe).....\$ 42.30 22.47

-----  
PLUM0047-005 05/01/2013

BEAVER, BUTLER, MCKEAN, MERCER, VENANGO, CLARION, LAWRENCE,  
FOREST, WARREN, CRAWFORD, AND ERIE COUNTIES

Rates Fringes

Plumbers and Pipefitters  
(Bridge Drain Pipe).....\$ 38.52 20.11

-----  
PLUM0354-005 06/01/2012

BEDFORD, BLAIR, CAMBRIA, CAMERON, CLEARFIELD, ELK, FAYETTE,  
GREENE (Extreme Eastern portion), HUNTINGDON, INDIANA,  
JEFFERSON, SOMERSE, WASHINGTON (Extreme Eastern portion), AND  
WESTMORELAND COUNTIES

Rates Fringes

Plumbers and Pipefitters  
(Bridge Drain Pipe).....\$ 35.54 19.97

-----  
TEAM0040-001 01/01/2019

Rates Fringes

TRUCK DRIVER (ALLEGHENY,  
 ARMSTRONG, BEAVER, BLAIR,  
 BUTLER, CAMBRIA, CENTRE,  
 CLARFIELD, CRAWFORD, ERIE,  
 FAYETTE, GREENE, INDIANA,  
 JEFFERSON, LAWRENCE, MCKEAN,  
 MERCER, SOMERSET, VENANGO,  
 WARREN, WASHINGTON, AND  
 WESTMORELAND)

GROUP 1.....	\$ 28.99	19.43
GROUP 2.....	\$ 29.13	19.51
GROUP 3.....	\$ 29.59	19.82

Truck drivers: (BEDFORD,  
 CAMERON, CLAIRON, CLINTON,  
 ELK, FOREST, FRANKLIN,  
 FULTON, HUNTINGDON, MIFFLIN,  
 AND POTTER COUNTIES)

GROUP 1.....	\$ 28.83	19.32
GROUP 2.....	\$ 28.99	19.43
GROUP 3.....	\$ 29.45	19.73

FOOTNOTES: A. Hazardous/toxic waste material/work level A  
 & B receive additional \$2.50 per hour above classification  
 rate

B. Hazardous/toxic waste materials/Work level C & D receive  
 \$1.00 per hour above classification

TRUCK DRIVERS CLASSIFICATIONS

GROUP 1 - Single Axle (2 axles including steering axle);  
 Includes partsman and warehoueman

GROUP 2 - Tandem - Tri-Axle - Semi-Tractor Trailer  
 (combination) (3 axles or more including steering axle)

GROUP 3 - Specialty Vehicles; Heavy equipment whose capacity  
 exceeds that for which state licenses are issued  
 specifically refers to units in excess of eight (8) feet  
 width (such as Euclids, Atley Wagon, Payloader,

Tournawagons, and similar equipment when not self loaded);  
Tar and Asphalt Distributors Trucks, Heavy Duty Trailer,  
such as Low Boy, High Boy

-----  
WELDERS - Receive rate prescribed for craft performing  
operation to which welding is incidental.

=====  
Note: Executive Order (EO) 13706, Establishing Paid Sick Leave  
for Federal Contractors applies to all contracts subject to the  
Davis-Bacon Act for which the contract is awarded (and any  
solicitation was issued) on or after January 1, 2017. If this  
contract is covered by the EO, the contractor must provide  
employees with 1 hour of paid sick leave for every 30 hours  
they work, up to 56 hours of paid sick leave each year.  
Employees must be permitted to use paid sick leave for their  
own illness, injury or other health-related needs, including  
preventive care; to assist a family member (or person who is  
like family to the employee) who is ill, injured, or has other  
health-related needs, including preventive care; or for reasons  
resulting from, or to assist a family member (or person who is  
like family to the employee) who is a victim of, domestic  
violence, sexual assault, or stalking. Additional information  
on contractor requirements and worker protections under the EO  
is available at [www.dol.gov/whd/govcontracts](http://www.dol.gov/whd/govcontracts).

Unlisted classifications needed for work not included within  
the scope of the classifications listed may be added after  
award only as provided in the labor standards contract clauses  
(29CFR 5.5 (a) (1) (ii)).

-----  
The body of each wage determination lists the classification  
and wage rates that have been found to be prevailing for the  
cited type(s) of construction in the area covered by the wage

determination. The classifications are listed in alphabetical order of ""identifiers"" that indicate whether the particular rate is a union rate (current union negotiated rate for local), a survey rate (weighted average rate) or a union average rate (weighted union average rate).

#### Union Rate Identifiers

A four letter classification abbreviation identifier enclosed in dotted lines beginning with characters other than ""SU"" or ""UAVG"" denotes that the union classification and rate were prevailing for that classification in the survey. Example:

PLUM0198-005 07/01/2014. PLUM is an abbreviation identifier of the union which prevailed in the survey for this classification, which in this example would be Plumbers. 0198 indicates the local union number or district council number where applicable, i.e., Plumbers Local 0198. The next number, 005 in the example, is an internal number used in processing the wage determination. 07/01/2014 is the effective date of the most current negotiated rate, which in this example is July 1, 2014.

Union prevailing wage rates are updated to reflect all rate changes in the collective bargaining agreement (CBA) governing this classification and rate.

#### Survey Rate Identifiers

Classifications listed under the ""SU"" identifier indicate that no one rate prevailed for this classification in the survey and the published rate is derived by computing a weighted average rate based on all the rates reported in the survey for that classification. As this weighted average rate includes all rates reported in the survey, it may include both union and non-union rates. Example: SULA2012-007 5/13/2014. SU indicates the rates are survey rates based on a weighted average calculation of rates and are not majority rates. LA indicates the State of Louisiana. 2012 is the year of survey on which these classifications and rates are based. The next number, 007 in the example, is an internal number used in producing the wage determination. 5/13/2014 indicates the survey completion

date for the classifications and rates under that identifier.

Survey wage rates are not updated and remain in effect until a new survey is conducted.

#### Union Average Rate Identifiers

Classification(s) listed under the UAVG identifier indicate that no single majority rate prevailed for those classifications; however, 100% of the data reported for the classifications was union data. EXAMPLE: UAVG-OH-0010 08/29/2014. UAVG indicates that the rate is a weighted union average rate. OH indicates the state. The next number, 0010 in the example, is an internal number used in producing the wage determination. 08/29/2014 indicates the survey completion date for the classifications and rates under that identifier.

A UAVG rate will be updated once a year, usually in January of each year, to reflect a weighted average of the current negotiated/CBA rate of the union locals from which the rate is based.

---

#### WAGE DETERMINATION APPEALS PROCESS

1.) Has there been an initial decision in the matter? This can be:

- \* an existing published wage determination
- \* a survey underlying a wage determination
- \* a Wage and Hour Division letter setting forth a position on a wage determination matter
- \* a conformance (additional classification and rate) ruling

On survey related matters, initial contact, including requests for summaries of surveys, should be with the Wage and Hour Regional Office for the area in which the survey was conducted because those Regional Offices have responsibility for the

Davis-Bacon survey program. If the response from this initial contact is not satisfactory, then the process described in 2.) and 3.) should be followed.

With regard to any other matter not yet ripe for the formal process described here, initial contact should be with the Branch of Construction Wage Determinations. Write to:

Branch of Construction Wage Determinations  
Wage and Hour Division  
U.S. Department of Labor  
200 Constitution Avenue, N.W.  
Washington, DC 20210

2.) If the answer to the question in 1.) is yes, then an interested party (those affected by the action) can request review and reconsideration from the Wage and Hour Administrator (See 29 CFR Part 1.8 and 29 CFR Part 7). Write to:

Wage and Hour Administrator  
U.S. Department of Labor  
200 Constitution Avenue, N.W.  
Washington, DC 20210

The request should be accompanied by a full statement of the interested party's position and by any information (wage payment data, project description, area practice material, etc.) that the requestor considers relevant to the issue.

3.) If the decision of the Administrator is not favorable, an interested party may appeal directly to the Administrative Review Board (formerly the Wage Appeals Board). Write to:

Administrative Review Board  
U.S. Department of Labor  
200 Constitution Avenue, N.W.  
Washington, DC 20210

4.) All decisions by the Administrative Review Board are final.

=====



END OF GENERAL DECISION"

**HOUSING AUTHORITY OF THE CITY OF PITTSBURGH**

**Request for Proposals**

**AUTHORITY WIDE SITE IMPROVEMENTS**

**ATTACHMENT M**

**Specifications**

## TABLE OF CONTENTS

<b>DIVISION</b>	<b>SECTION</b>
-----------------	----------------

---

<b>DIVISION 00</b>	<b>PROCUREMENT AND CONTRACTING REQUIREMENTS</b>
--------------------	---

00 00 00	Special Provisions
----------	--------------------

<b>DIVISION 02</b>	<b>EXISTING CONDITIONS</b>
--------------------	----------------------------

02 41 12	Selective Site Demolition - Sawcutting
----------	--

02 41 13	Selective Site Demolition
----------	---------------------------

<b>DIVISION 05</b>	<b>METALS</b>
--------------------	---------------

05 50 00	Metal Fabrications
----------	--------------------

<b>DIVISION 06</b>	<b>WOOD, PLASTICS, AND COMPOSITES</b>
--------------------	---------------------------------------

06 61 00	Fiberglass Reinforced Plastics (FRP) Fabrications
----------	---

<b>DIVISION 09</b>	<b>FINISHES</b>
--------------------	-----------------

09 96 00	High-Performance Coatings
----------	---------------------------

<b>DIVISION 10</b>	<b>SPECIALTIES</b>
--------------------	--------------------

10 14 26	Post and Panel Signage
----------	------------------------

10 75 00	Flagpoles
----------	-----------

<b>DIVISION 31</b>	<b>EARTHWORK</b>
--------------------	------------------

31 11 00	Clearing and Grubbing
----------	-----------------------

31 12 00	Selective Clearing
----------	--------------------

31 13 13	Selective Tree and Shrub Removal
----------	----------------------------------

31 13 16	Selective Tree and Shrub Trimming
----------	-----------------------------------

31 22 16	Fine Grading
----------	--------------

31 23 13	Subgrade Preparation
----------	----------------------

31 23 16	Excavation
----------	------------

31 23 23	Fill
----------	------

31 23 33	Trenching and Backfilling
----------	---------------------------

<b>DIVISION 32</b>	<b>EXTERIOR IMPROVEMENTS</b>
--------------------	------------------------------

32 01 16	Flexible Paving Rehabilitation
----------	--------------------------------

32 01 17	Flexible paving Repair
----------	------------------------

32 01 26	Rigid Paving Rehabilitation
----------	-----------------------------

32 05 16	Aggregates for Exterior Improvements
----------	--------------------------------------

32 11 23	Aggregate Base Courses
----------	------------------------

32 12 19	Asphalt Paving Wearing Courses
----------	--------------------------------

32 13 13	Concrete Paving
----------	-----------------

32 14 16	Brick Unit Paving
----------	-------------------

32 14 40	Stone Paving
----------	--------------

32 16 13	Curbs and Gutters
----------	-------------------

32 16 23	Sidewalks
----------	-----------

32 16 33	Driveways
----------	-----------

32 17 13	Parking Bumpers
----------	-----------------

32 17 23	Pavement Markings
----------	-------------------

32 17 26	Tactile Warning Surfacing
----------	---------------------------

32 31 13	Chain Link Fences and Gates
----------	-----------------------------

32 32 13	Cast-in-Place Concrete Retaining Walls
----------	--

32 32 23	Segmental Retaining Walls
----------	---------------------------

32 91 19	Landscape Grading
----------	-------------------

32 92 00	Turf and Grasses
----------	------------------

Housing Authority of the City of Pittsburgh  
Authority-wide Site Improvements

32 92 13 Hydro-Mulching  
32 94 43 Tree Grates

**DIVISION 33 UTILITIES**

33 12 13 Water Service Connections  
33 33 13 Sanitary Utility Sewerage  
33 41 13 Public Storm Utility Drainage Piping  
33 46 16 Subdrainage Piping  
33 49 13 Storm Drainage Manholes, Frames, and Covers

**DIVISION 34 TRANSPORTATION**

34 71 13 Vehicle Barriers

END OF TABLE OF CONTENTS

## **SPECIAL PROVISIONS**

### **THE RENOVATION AND REPLACEMENT OF SITE CIVIL AND ARCHITECTURAL ITEMS FOR THE HOUSING AUTHORITY OF THE CITY OF PITTSBURGH**

#### **ITEM DESCRIPTIONS**

The descriptions of items that follow are those that deviate from and/or supplement the item description in the Standard Specifications.

In making the Proposal, it is understood that all quantities shown in the Proposal may be increased without limitations to the extent ordered by the Director; and payment for those items, in any quantity, will be made at unit prices bid thereof.

END OF SECTION 00 00 00

[THIS PAGE BLANK]

**SECTION 02 41 12 – SELECTIVE SITE DEMOLITION – SAWCUTTING**

**ITEM 02 41 12.0010 SAW CUTTING: BITUMINOUS PAVEMENT**

**ITEM 02 41 12.0011 SAW CUTTING: CONCRETE PAVEMENT**

**ITEM 02 41 12.0012 SAW CUTTING: MISCELLANEOUS CONCRETE STRUCTURES**

**PART I: DESCRIPTION**

- A. 0010 – Full depth saw cut of existing bituminous pavement including removal and disposal of waste material resulting from saw cutting operations.
- B. 0011 – Full depth saw cut of existing concrete pavement including removal and disposal of waste material resulting from saw cutting operations.
- C. 0012 – Saw cut at variable depth of existing concrete structures for the purpose of rehabilitation or removal including removal and disposal of waste material resulting from saw cutting operations.

**PART II: GENERAL**

- A. When ordered by Director, saw cut surface, in accordance with Director's instructions as determined in the field and the applicable Sections of City of Pittsburgh Specifications.
- B. Location and extent of saw cutting is to conform to the orders of the Director given in the field.

**PART III: PRODUCTS AND MATERIALS [NOT USED]**

**PART IV: CONSTRUCTION AND EXECUTION**

- A. In all areas where proposed construction matches existing conditions full depth saw cutting shall be required to provide a separation of work.
- B. Unless otherwise specified all pavement edges will require saw cutting as necessary to deter pavement damage and subsequent repair. Saw cut to provide a smooth transition between the existing pavement and the restored pavement.

**PART V: MEASUREMENT AND PAYMENT**

**A. SAW CUTTING: BITUMINOUS PAVEMENT. Linear Foot.**

**SAW CUTTING: CONCRETE PAVEMENT. Linear Foot.**

**SAW CUTTING: MISCELLANEOUS CONCRETE STRUCTURES. Linear Foot.**

- 1. Payment will be made at the Unit Price Bid per linear foot of saw cutting.
- 2. Payment is full compensation for the work described for the item, including all necessary labor, tools, machinery, and incidentals required to complete the work.

END OF SECTION 02 41 12

[THIS PAGE BLANK]



**SECTION 02 41 13 – SELECTIVE SITE DEMOLITION**

**ITEM 02 41 13.0011 REMOVE BITUMINOUS SURFACE: LESS THAN OR EQUAL TO 6" DEPTH**

**ITEM 02 41 13.0012 REMOVE BITUMINOUS SURFACE: GREATER THAN 6" DEPTH**

**PART I: DESCRIPTION**

- A. 0001 – Removal of bituminous surface, full depth less than or equal to 6".
- B. 0002 – Removal of bituminous surface, full depth greater than 6".

**PART II: GENERAL**

- A. When ordered by Director, remove bituminous pavement, in accordance with Director's instructions as determined in the field and the applicable Sections of City of Pittsburgh Specifications. The extent of removal is to conform to the orders of the Director given in the field.

**PART III: PRODUCTS AND MATERIALS [NOT USED]**

**PART IV: CONSTRUCTION AND EXECUTION**

- A. Protect existing structures and other elements that are not to be removed.
  - 1. Provide bracing and shoring.
  - 2. Prevent movement or settlement of adjacent structures.
  - 3. Stop work immediately if adjacent structures appear to be in danger.
- B. Remove existing pavement as directed and as required to accomplish new work.
  - 1. Use an acceptable removal method.
  - 2. Neatly trim edges of remaining material.
  - 3. Repair subbase as required to accomplish new work.
- C. Protect existing work to remain.
  - 1. Prevent movement of structure; provide shoring and bracing if necessary.
  - 2. Perform cutting to accomplish removals neatly and as specified for cutting new work.
  - 3. Repair adjacent construction and finishes damaged during removal work.
  - 4. Patch as specified for patching new work.
- D. Debris and waste removal
  - 1. Remove debris, junk, and trash from site.

**PART V: MEASUREMENT AND PAYMENT**

- A. **REMOVE BITUMINOUS SURFACE: LESS THEN OR EQUAL TO 6" DEPTH. Square Yard.**

**REMOVE BITUMINOUS SURFACE: GREATER THAN 6" DEPTH. Square Yard.**

- 1. Payment will be made at the Unit Price Bid per square yard of bituminous pavement removed.
- 2. Payment is full compensation for the work described for the item, including all necessary labor, tools, machinery, and materials required to complete the work.

**ITEM 02 41 13.0021 REMOVE CONCRETE PAVEMENT: LESS THAN OR EQUAL TO 6" DEPTH**

**ITEM 02 41 13.0022 REMOVE CONCRETE PAVEMENT: GREATER THAN 6" DEPTH**

**PART I: DESCRIPTION**

- A. 0021 – Removal of concrete pavement, full depth less than or equal to 6”.
- B. 0022 – Removal of concrete pavement, full depth greater than 6”.

**PART II: GENERAL**

- A. When ordered by Director, remove concrete pavement, in accordance with Director’s instructions as determined in the field and the applicable Sections of City of Pittsburgh Specifications. The extent of removal is to conform to the orders of the Director given in the field.

**PART III: PRODUCTS AND MATERIALS [NOT USED]**

**PART IV: CONSTRUCTION AND EXECUTION**

- A. Protect existing structures and other elements that are not to be removed.
  - 1. Provide bracing and shoring.
  - 2. Prevent movement or settlement of adjacent structures.
  - 3. Stop work immediately if adjacent structures appear to be in danger.
- B. Remove existing pavement as directed and as required to accomplish new work.
  - 1. Use an acceptable removal method.
  - 2. Neatly trim edges of remaining material.
  - 3. Repair subbase as required to accomplish new work.
- C. Protect existing work to remain.
  - 1. Prevent movement of structure; provide shoring and bracing if necessary.
  - 2. Perform cutting to accomplish removals neatly and as specified for cutting new work.
  - 3. Repair adjacent construction and finishes damaged during removal work.
  - 4. Patch as specified for patching new work.
- D. Debris and waste removal
  - 1. Remove debris, junk, and trash from site.

**PART V: MEASUREMENT AND PAYMENT**

- A. **REMOVE CONCRETE PAVEMENT: LESS THEN OR EQUAL TO 6" DEPTH. Square Yard.**

**REMOVE CONCRETE PAVEMENT: GREATER THAN 6" DEPTH. Square Yard.**

- 1. Payment will be made at the Unit Price Bid per square yard of pavement removed.
- 2. Payment is full compensation for the work described for the item, including all necessary labor, tools, machinery, and materials required to complete the work.

**ITEM 02 41 13.0030 REMOVE SUBBASE**

**PART I: DESCRIPTION**

- A. 0030 – Removal of subbase material to subgrade.

**PART II: GENERAL**

- A. When ordered by Director, remove subbase, in accordance with Director's instructions as determined in the field and the applicable Sections of City of Pittsburgh Specifications.  
The extent subbase removal is to conform to the orders of the Director given in the field.

**PART III: PRODUCTS AND MATERIALS [NOT USED]**

**PART IV: CONSTRUCTION AND EXECUTION**

- A. Remove existing subbase course as directed.
- B. Use an acceptable removal method.
- C. Neatly trim edges of remaining material.
- D. Repair subgrade as required to accomplish new work.

**PART V: MEASUREMENT AND PAYMENT**

- A. **REMOVE SUBBASE. Cubic Yard.**
  - 1. Payment will be made at the Unit Price Bid per cubic yard of subbase removed.
  - 2. Payment is full compensation for the work described for the item, including all necessary labor, tools, machinery, and materials required to complete the work.

**ITEM 02 41 13.0040 REMOVE CURB**

**ITEM 02 41 13.0050 REMOVE CONCRETE OR BRICK GUTTERS**

**ITEM 02 41 13.0060 REMOVE MISCELLANEOUS CONCRETE STRUCTURES**

**PART I: DESCRIPTION**

- A. 0040 – Removal of curb.
- B. 0050 – Removal of gutters.
- C. 0060 – Removal of concrete structures.

**PART II: GENERAL**

- A. When ordered by Director, remove curb, gutter and concrete structures, in accordance with Director's instructions as determined in the field and the applicable Sections of City of Pittsburgh Specifications. The extent demolition is to conform to the orders of the Director given in the field.

**PART III: PRODUCTS AND MATERIALS [NOT USED]**

**PART IV: CONSTRUCTION AND EXECUTION**

- A. General Procedures and Project Conditions
  - 1. Comply with applicable codes and regulations for demolition operations and safety of adjacent structures and the public.
    - a. Take precautions to prevent catastrophic or uncontrolled collapse of structures to be removed; do not allow worker or public access within range of potential collapse of unstable structures.
    - b. Provide, erect, and maintain temporary barriers and security devices.
    - c. Use physical barriers to prevent access to areas that could be hazardous to workers or the public.
    - d. Conduct operations to minimize effects on and interference with adjacent structures and occupants.
    - e. Do not close or obstruct roadways or sidewalks without permit.
    - f. Conduct operations to minimize obstruction of public and private entrances and exits; do not obstruct required exits at any time; protect persons using entrances and exits from removal operations.
- B. Do not begin removal until built elements to be salvaged or relocated have been removed.
- C. Protect existing structures and other elements that are not to be removed.
  - 1. Provide bracing and shoring.
  - 2. Prevent movement or settlement of adjacent structures.
  - 3. Stop work immediately if adjacent structures appear to be in danger.
- D. Partial Removal of Curbs and Gutter: Neatly saw cut at right angle to surface.
- E. Remove existing work as indicated and as required to accomplish new work.
- F. Protect existing work to remain.
  - 1. Prevent movement of structure; provide shoring and bracing if necessary.
  - 2. Perform cutting to accomplish removals neatly and as specified for cutting new work.
  - 3. Repair adjacent construction and finishes damaged during removal work.
  - 4. Patch as specified for patching new work.
- G. Debris and Waste Removal
  - 1. Remove debris, junk, and trash from site.

2. Leave site in clean condition, ready for subsequent work.

**PART V: MEASUREMENT AND PAYMENT**

**A. REMOVE CURB. Linear Foot.**

1. Payment will be made at the Unit Price Bid per linear foot of curb removed.
2. Payment is full compensation for the work described for the item, including all necessary labor, tools, machinery, and materials required to complete the work.

**B. REMOVE CONCRETE OR BRICK GUTTERS. Square Yard.**

1. Payment will be made at the Unit Price Bid per square yard of gutters removed.
2. Payment is full compensation for the work described for the item, including all necessary labor, tools, machinery, and materials required to complete the work.

**C. REMOVE MISCELLANEOUS CONCRETE STRUCTURES. Cubic Yard.**

1. Payment will be made at the Unit Price Bid per cubic yard of material removed from a miscellaneous concrete structure.
2. Payment is full compensation for the work described for the item, including all necessary labor, tools, machinery, and materials required to complete the work.

END OF SECTION 02 41 13

[THIS PAGE BLANK]

SECTION 05 50 00 – METAL FABRICATIONS

**PART I: GENERAL**

1. RELATED DOCUMENTS
  - A. Drawings and general provisions of the Contract, including General and Supplementary Conditions and Division 01 Specification Sections, apply to this Section.
2. SUMMARY
  - A. Section includes:
    1. Pipe railings.
    2. Steel Bollards.
    3. Loose steel angles for other assemblies.
  - B. Related Sections:
    1. “Cast-in-Place Concrete” for installing bolts, steel pipe sleeves, and other items cast into concrete.
3. PERFORMANCE REQUIREMENTS
  - A. Thermal Movements: Allow for thermal movements from ambient and surface temperature changes acting on exterior metal fabrications by preventing buckling, opening of joints, overstressing of components, failure of connections, and other detrimental effects.
    1. Temperature Change: 120 deg F, ambient; 180 deg F, material surfaces.
4. ACTION SUBMITTALS
  - A. Shop Drawings: Show fabrication and installation details for metal fabrications.
    1. Include plans, elevations, sections, and details of metal fabrications and their connections. Show anchorage and accessory items.
5. QUALITY ASSURANCE
  - A. Welding Qualifications: Qualify procedures and personnel according to the following:
    1. AWS D1.1/D1.1M, “Structural Welding Code- Steel.”
    2. AWS D1.6, “Structural Welding Code-Stainless Steel.”
6. PROJECT CONDITIONS
  - A. Field Measurements: Verify actual locations of foundations and other construction contiguous with metal fabrications by field measurements before fabrication.
7. COORDINATION
  - A. Coordinate installation of anchorages. Furnish setting drawings, templates, and directions for installing anchorages, including sleeves, concrete inserts, anchor bolts, and items with integral anchors, that are to be embedded in concrete or masonry. Deliver such items to Project site in time for installation.

**PART II: PRODUCTS**

1. METALS, GENERAL
  - A. Metal Surfaces, General: Provide materials with smooth, flat surfaces unless otherwise indicated. For metal fabrications exposed to view in the completed Work, provide materials without seam marks, roller marks, rolled trade names, or blemishes.
2. METALS
  - A. Steel Plates, Shapes, and Bars: ASTM A 36/A 36M.
3. FASTENERS
  - A. General: Unless otherwise indicated, provide Type 316 stainless-steel fasteners for exterior use.
  - B. Stainless-Steel Bolts and Nuts: Regular hexagon-head annealed stainless-steel bolts, ASTM F 593; with hex nuts, ASTM F 594; and, where indicated, flat washers and retaining washers.
  - C. Anchor Bolts: As indicated, or if not, use ASTM F 1554, Grade 36, of dimensions indicated; with nuts, ASTM A 563; and, where indicated, flat washers.

1. Hot-dip galvanize or provide mechanically deposited, zinc coating where item being fastened is indicated to be galvanized.
4. MISCELLANEOUS MATERIALS
  - A. Welding Rods and Bare Electrodes: Select according to AWS specifications for metal alloy welded.
  - B. Galvanizing Repair Paint: High-zinc-dust-content paint complying with SSPC-Paint 20 and compatible with paints specified to be used over it.
  - C. Bituminous Paint: Cold-applied asphalt emulsion complying with ASTM D 1187.
  - D. Nonshrink, Nonmetallic Grout: Factory-packaged, nonstaining, noncorrosive, nongaseous grout complying with ASTM C 1107. Provide grout specifically recommended by manufacturer for exterior applications.
5. FABRICATION, GENERAL
  - A. Shop Assembly: Preassemble items in the shop to greatest extent possible. Disassemble units only as necessary for shipping and handling limitations. Use connections that maintain structural value of joined pieces. Clearly mark units for reassembly and coordinated installation.
  - B. Cut, drill, and punch metals cleanly and accurately. Remove burrs and ease edges to a radius of approximately 1/32 inch unless otherwise indicated. Remove sharp or rough areas on exposed surfaces.
  - C. Form bent-metal corners to smallest radius possible without causing grain separation or otherwise impairing work.
  - D. Form exposed work with accurate angles and surfaces and straight edges.
  - E. Weld corners and seams continuously to comply with the following:
    1. Use of materials and methods that minimize distortion and develop strength and corrosion resistance of base metals.
    2. Obtain fusion without undercut or overlap.
    3. Remove welding flux immediately.
    4. At exposed connections, finish exposed welds and surfaces smooth and blended so no roughness shows after finishing and contour of welded surface matches that of adjacent surface.
  - F. Form exposed connections with hairline joints, flush and smooth, using concealed fasteners or welds where possible. Where exposed fasteners are required, use tamper-resistant flat-head (countersunk) fasteners unless otherwise indicated. Locate joints where least conspicuous.
  - G. Fabricate seams and other connections that will be exposed to weather in a manner to exclude water. Provide weep holes where water may accumulate.
  - H. Cut, reinforce, drill, and tap metal fabrications as indicated to receive finish hardware, screws, and similar items.
  - I. Provide for anchorage of type indicated; coordinate with supporting structure. Space anchoring devices to secure metal fabrications rigidly in place and to support indicated loads.
6. FINISHES, GENERAL
  - A. Comply with NAAMM's "Metal Finishes Manual for Architectural and Metal Products" for recommendations for applying and designating finishes.
  - B. Finish metal fabrications after assembly.
  - C. Finish exposed surfaces to remove tool and die marks and stretch lines, and to blend into surrounding surface.
7. STEEL FINISHES
  - A. Galvanizing: Hot-dip galvanize items as indicated to comply with ASTM A 153/A 153M for steel and iron hardware and with ASTM A 123/A 123M for other steel and iron products.



1. Do not quench or apply post galvanizing treatments that might interfere with sealant adhesion.

**PART III: EXECUTION**

1. INSTALLATION, GENERAL

- A. Cutting, Fitting, and Placement: Perform cutting, drilling, and fitting required for installing metal fabrications. Set metal fabrications accurately in location, alignment, and elevation; with edges and surfaces level, plumb, true, and free of rack; and measured from established lines and levels.
- B. Fit exposed connections accurately together to form hairline joints. Weld connections that are not to be left as exposed joints but cannot be shop welded because of shipping size limitations. Do not weld, cut, or abrade surfaces of exterior units that have been hot-dip galvanized after fabrication and are for bolted or screwed field connections.
- C. Field Welding: Comply with the following requirements:
  1. Use materials and methods that minimize distortion and develop strength and corrosion resistance of base materials.
  2. Obtain fusion without undercut or overlap.
  3. Remove welding flux immediately.
  4. At exposed connections, finish exposed welds and surfaces smooth and blended so no roughness shows after finishing and contour of welded surface matches that of adjacent surface.
- D. Fastening to In-Place Construction: Provide anchorage devices and fasteners where metal fabrications are required to be fastened to in-place construction. Provide threaded fasteners for use with concrete and masonry inserts, toggle bolts, through bolts, lag screws, and other connectors.
- E. Provide temporary bracing or anchors in formwork for items that are to be built into concrete, masonry, or similar construction.

2. ADJUSTING AND CLEANING

- A. Galvanized Surfaces: Clean field welds, bolted connections, and abraded areas and repair galvanizing to comply with ASTM A 780.

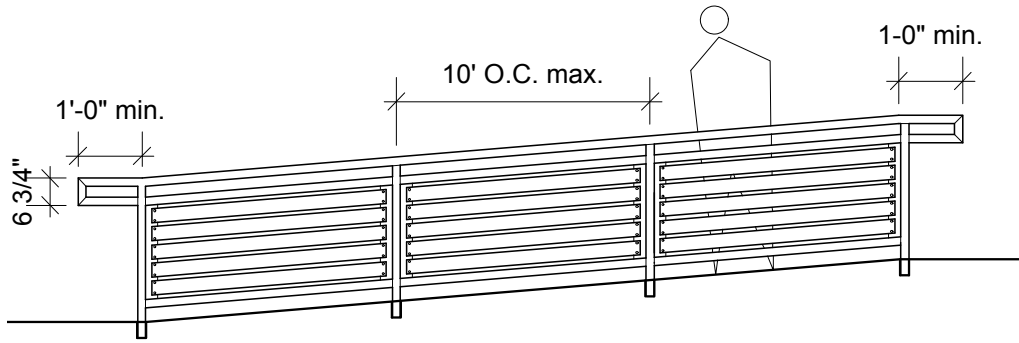

1 ADA Ramp Railing Elevation  
 Scale: 1/4" = 1'-0"

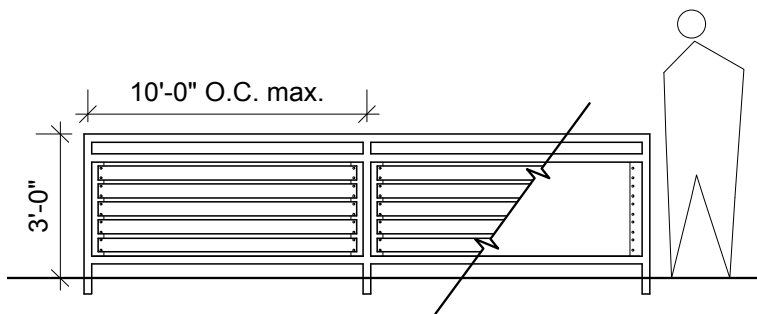

2 Railing Elevation  
 Scale: 1/4" = 1'-0"

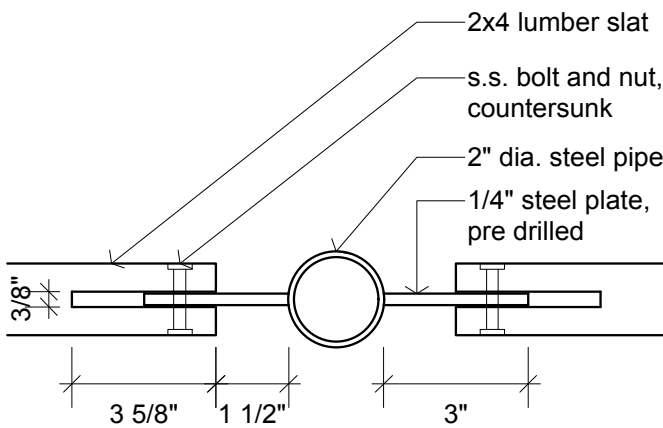

3 Plan Detail  
 Scale: 3" = 1'-0"

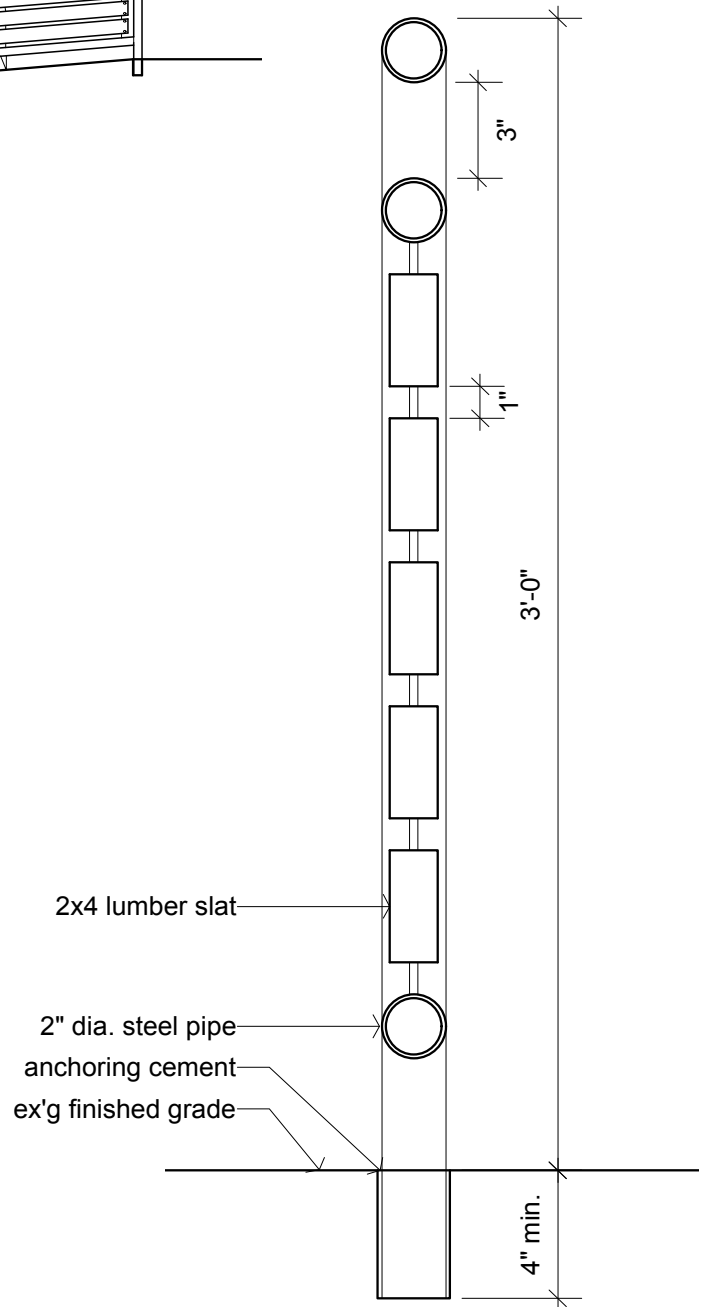

4 Railing Cross-section  
 Scale: 2" = 1'-0"

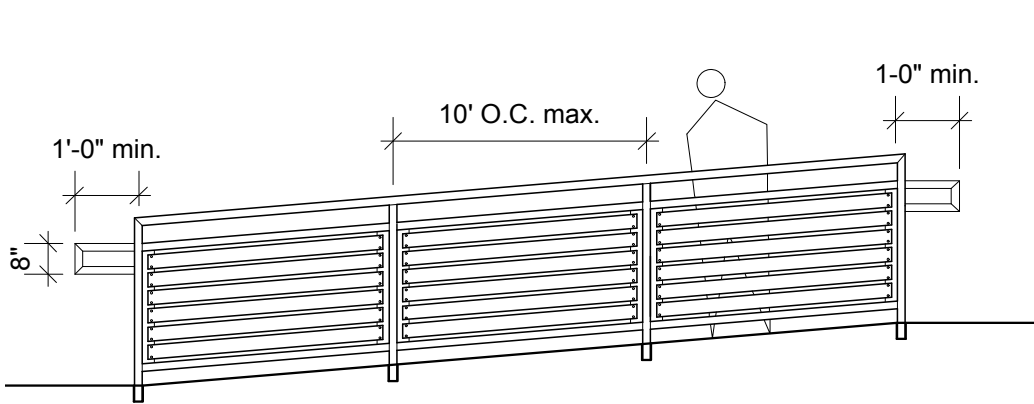

1 ADA Ramp Guard/Railing Elevation  
 Scale: 1/4" = 1'-0"

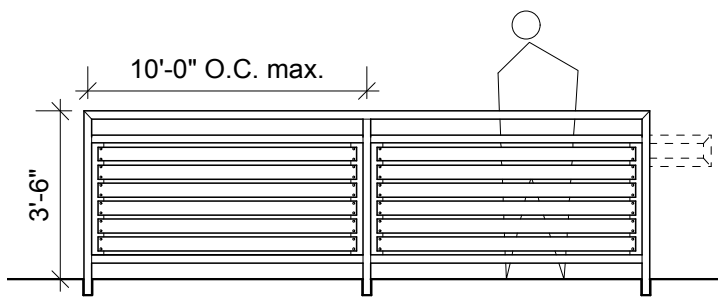

2 Guard Elevation  
 Scale: 1/4" = 1'-0"

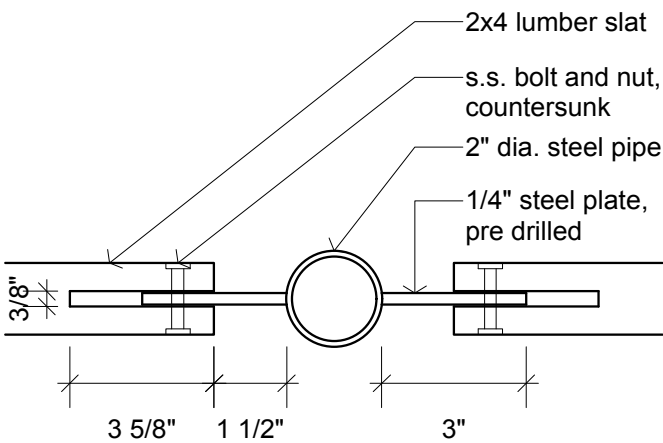

3 Plan Detail  
 Scale: 3" = 1'-0"

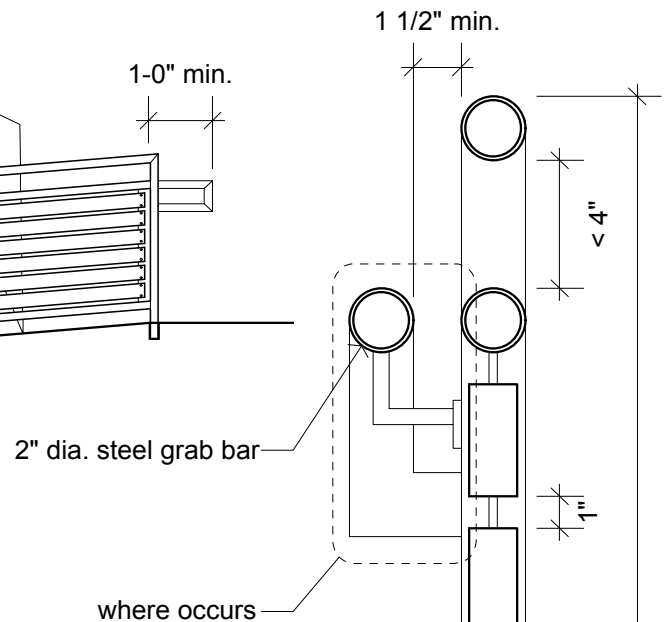

4 Railing Cross-section  
 Scale: 2" = 1'-0"

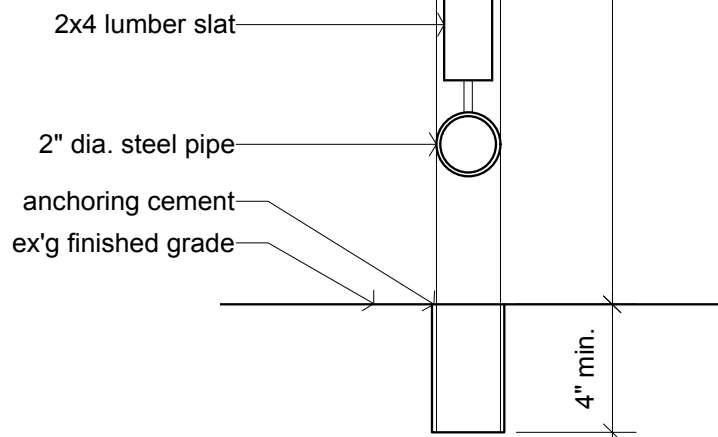

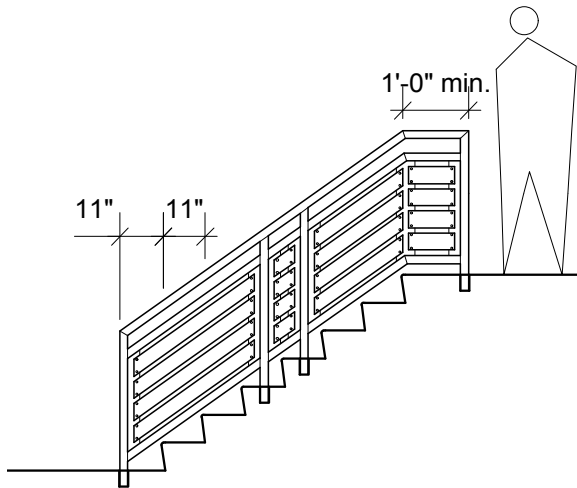

1 Stair Railing Elevation  
 Scale: 1/4" = 1'-0"

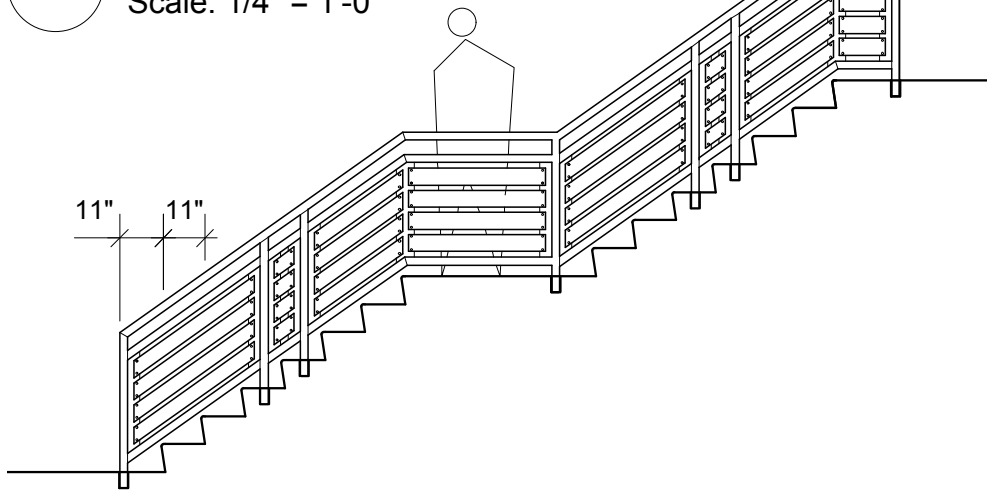

2 Stair Railing Elevation  
 Scale: 1/4" = 1'-0"

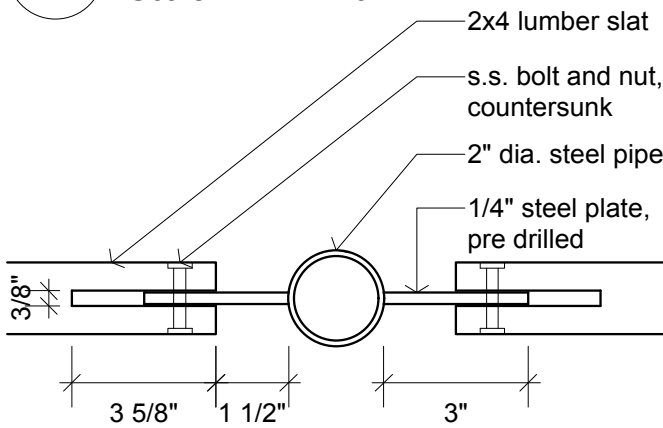

3 Plan Detail  
 Scale: 3" = 1'-0"

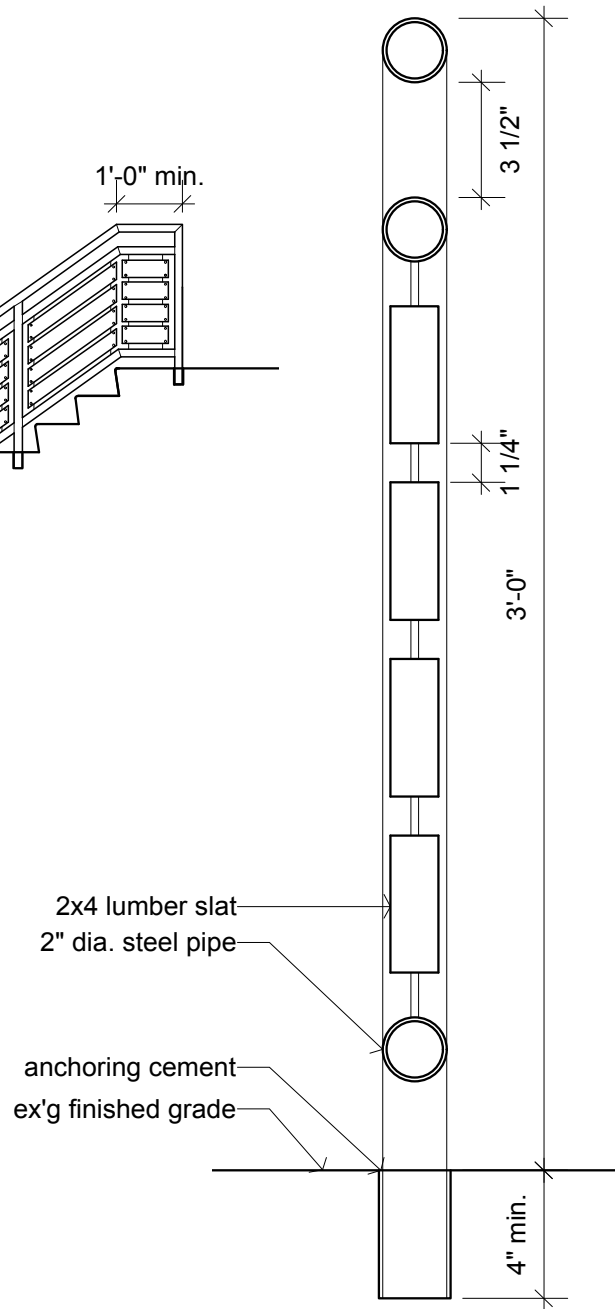

4 Railing Cross-section  
 Scale: 2" = 1'-0"

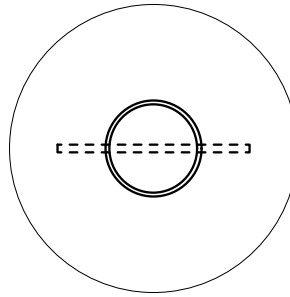

1 **Bollard Plan**  
Scale: 1" = 1'-0"

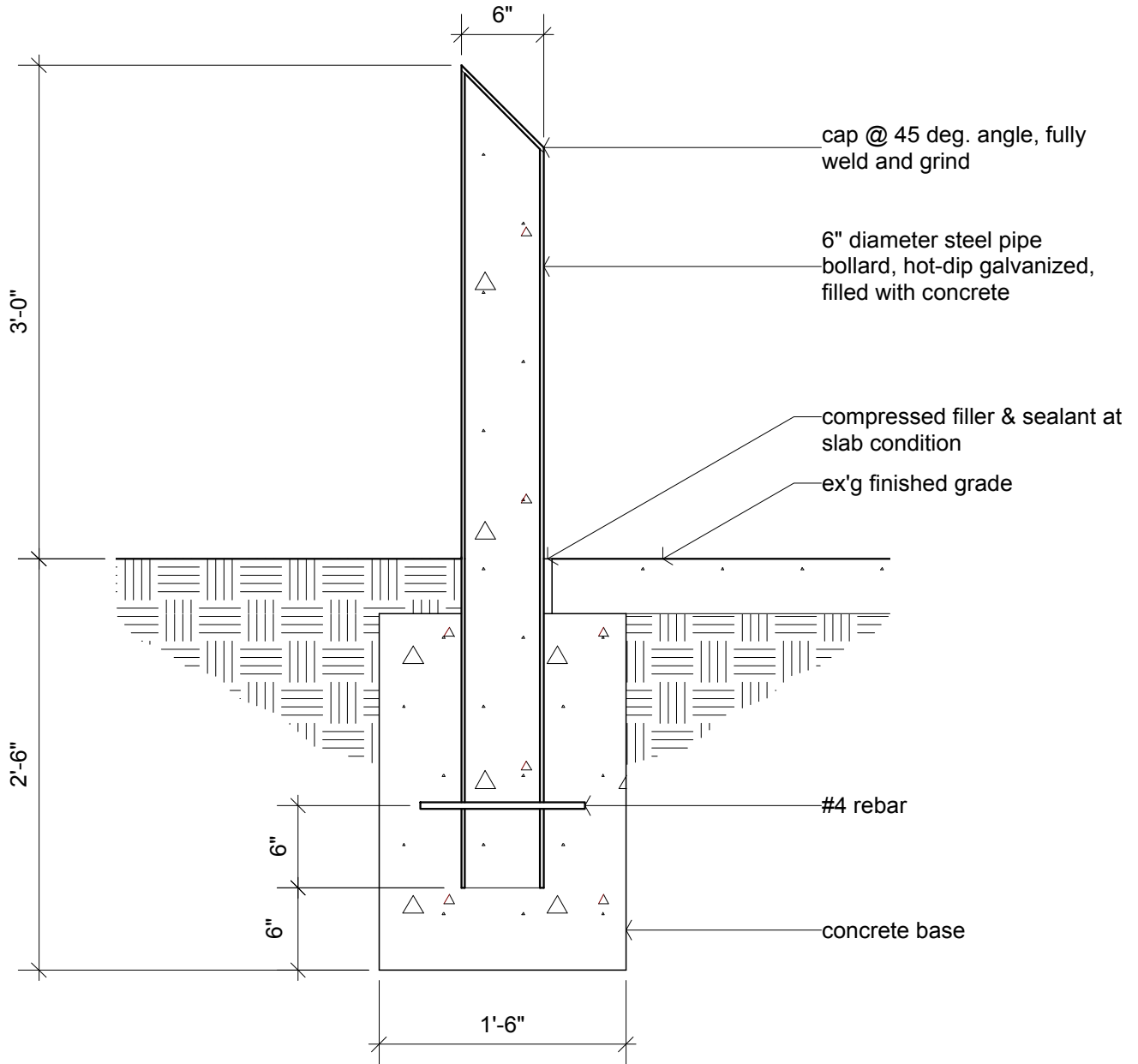

2 **Steel Pipe Bollard**  
Scale: 1" = 1'-0"

END OF SECTION 05 50 00

SECTION 06 61 00 – FIBERGLASS REINFORCED PLASTICS (FRP) FABRICATIONS

**PART I: GENERAL**

1. RELATED DOCUMENTS
  - A. Drawings and general provisions of the Contract, including General and Supplementary Conditions and Division 01 Specification Sections, apply to this Section.
2. SUMMARY
  - A. Section includes:
    1. Shop fabricated fiberglass reinforced plastic (FRP) pultruded gratings.
  - B. Related Sections:
    1. “Metal Fabrications” for installing loose steel angles.
3. SCOPE OF WORK
  - A. Furnish, fabricate (where necessary), and install all fiberglass reinforced plastic (FRP) gratings with all appurtenances, accessories and incidentals necessary to produce a complete, operable and serviceable installation as specified herein.
4. ACTION SUBMITTALS
  - A. Submit manufacturer’s shop drawings of all fabricated gratings clearly showing material sizes, types, styles, part or catalog numbers, complete details for the fabrication of and erection of components including, but not limited to, location, lengths, type and sizes of fasteners, clip angles, member sizes, and connection details.
  - B. Submit the manufacturer’s published literature including structural design data, structural properties data, grating load/deflection tables, corrosion resistance tables, certificates of compliance, test reports as applicable and design calculations for systems not sized or designed in the contract documents.
  - C. Submit sample pieces of each item specified herein, manufactured by the method used in the Work and as to quality and color.
5. DESIGN CRITERIA
  - A. The design criteria of the FRP products including connections shall be in accordance with the governing building codes and generally accepted standards in the FRP industry.
  - B. Gratings: Design live loads of the FRP gratings for walkway applications shall be 50psf uniformly distributed load (or as required by the governing building code) with a maximum deflection of 3/8” or L/120 at the center of a simple span or a concentrated load of 250 pounds with a maximum deflection of 1/4” at the center of a simple span.
6. PRODUCT DELIVERY AND STORAGE
  - A. All gratings and components shall be shop fabricated. Piece match marked to assembly or erection drawings.
  - B. Delivery of Materials: All manufactured materials shall be delivered in original, unbroken pallets, packages, containers, or bundles bearing the label of the manufacturer. Adhesives, resins, and their catalysts and their hardeners shall be crated or boxed separately and noted as such to facilitate their movement to a dry indoor storage facility.
  - C. Storage of Products: All materials - before, during, and after shipment – shall be carefully handled to prevent them from abrasion, cracking, chipping, twisting, other deformations, and other types of damage. Store items in an enclosed area and free from contact with soil and water. Store adhesives, resins, and their catalysts and hardeners in dry indoor facilities between 70 and 85 degrees Fahrenheit until they are required.

**PART II: PRODUCTS**

1. MANUFACTURERS
  - A. McNichols
  - B. Fibergrate Composite Structures Inc.
  - C. AMD, Inc.
2. GENERAL

- A. All FRP items furnished under this Section shall be composed of fiberglass reinforcement and resin in qualities, quantities, properties, arrangements, and dimensions as necessary to meet the design requirements and dimensions as specified in the Contract Documents.
  - B. Fiberglass reinforcement for pultruded grating shall be continuous roving. Additionally for pultruded gratings, reinforcements shall include a combination of continuous strand mat and surfacing veils. All reinforcements shall be in sufficient quantities as needed by the application and/or physical properties required.
  - C. Resins shall be Vinyl Ester or Polyester with chemical formulations as necessary to provide the corrosion resistance, strength, and other physical properties as required.
  - D. All finished surfaces of FRP items and fabrications shall be smooth, resin-rich, free of voids and without dry spots, cracks, crazes, or unreinforced areas. All glass fibers shall be well covered with resin to protect against their exposure due to wear or weathering.
  - E. All pultruded components shall be further protected from ultraviolet (UV) light with 1) integral UV inhibitors in the resin and 2) a synthetic surfacing veil to help produce a resin rich surface.
  - F. All FRP products shall have a tested flame spread rating of 25 or less per ASTM E84 test.
  - G. All grating clips shall be manufactured of type 316SS (stainless steel).
  - H. After fabrication, all cut ends, holes, and abrasions of FRP grating shall be sealed with a resin comparable to the grating panel.
3. PULTRUDED GRATING
- A. Manufacture: Grating components shall be manufactured by the pultusion process, shall be of high strength and high stiffness elements having a maximum of 70% and a minimum of 60% glass content (by weight) of continuous roving and continuous strand mat fiberglass reinforcements. The finished surface of the product shall be provided with a surfacing veil to provide a resin rich surface which improves corrosion resistance and resistance to ultraviolet degradation.
  - B. Grating bearing bars shall be joined into panels, interlocked and epoxied into the proper spacing by passing a continuous, notched cross rod or cross rods through the web of each bearing bar. The notches shall be spaced on centers to match the distance between the load bars. A continuous keeper shall be driven behind the notched cross rod to affix it into place. Chemically bonding shall complete the assembly of the cross bar system to ensure both a mechanical and chemical lock.
  - C. Non-slip surfacing: Grating shall be provided with a grit bonded to the top surface of the finished grating product.
  - D. Color: Gray
  - E. Grating configuration shall be 1" deep (Wide T bar) T 1210 bearing bar; 1.85" load bar spacing, 12% open area, 6" tie bar spacing on centers.
  - F. Substitutions: other products of equal strength, stiffness, corrosion resistance, and overall quality may be submitted with the proper supporting data for approval.
4. GRATING FABRICATION
- A. Measurements: Grating supplied shall meet the minimum dimensional requirements or specified. The contractor shall provide and/or verify measurements in field for work fabricated to fit field conditions as required by grating manufacturer to complete the work. Determine correct size and locations of required holes or cutouts from field dimensions before grating fabrication.
  - B. Layout: Each grating section shall be securely fastened to substrate. Manufacturer to provide opening and holes where located on the contract drawings. Gratings shall be fabricated free from wraps, twists, or other defects which affect appearance and serviceability.
  - C. Sealing: All shop fabricated grating cuts shall be coated with a resin comparable to grating resin to provide maximum corrosion resistance. All field fabricated grating cuts



shall be coated similarly by the contractor in accordance with the manufacturer's instructions.

- D. Hardware: Type 316SS Hold-down clips shall be provided and spaced at a maximum of four feet apart with a minimum of four per piece of grating, or as recommended by the manufacturer. Tamper-resistant anchor bolts shall be type 316SS.

**PART III: EXECUTION**

1. INSPECTION

- A. Shop inspection is authorized as required by the owner and shall be at Owner's expense. The fabricator shall give ample notice to the Contractor prior to the beginning of any fabrication work so that inspection may be provided.
- B. The grating shall be as free, as commercially possible, from visual defects such as foreign inclusions, delamination, blisters, resin burns, air bubbles, and pits.

2. INSTALLATION

- A. Contractor shall install gratings in accordance with manufacturer's assembly drawings. Lock grating panels securely in place with hold-down fasteners as specified herein.
- B. Field cut and drill fiberglass reinforced plastic products with carbide or diamond tipped bits and blades. Seal cut or drilled surfaces in accordance with manufacturer's instructions. Follow manufacturer's instructions when cutting or drilling fiberglass products or using resin products; provide adequate ventilation.
- C. Install items specified as indicated and in accordance with manufacturer's instructions.

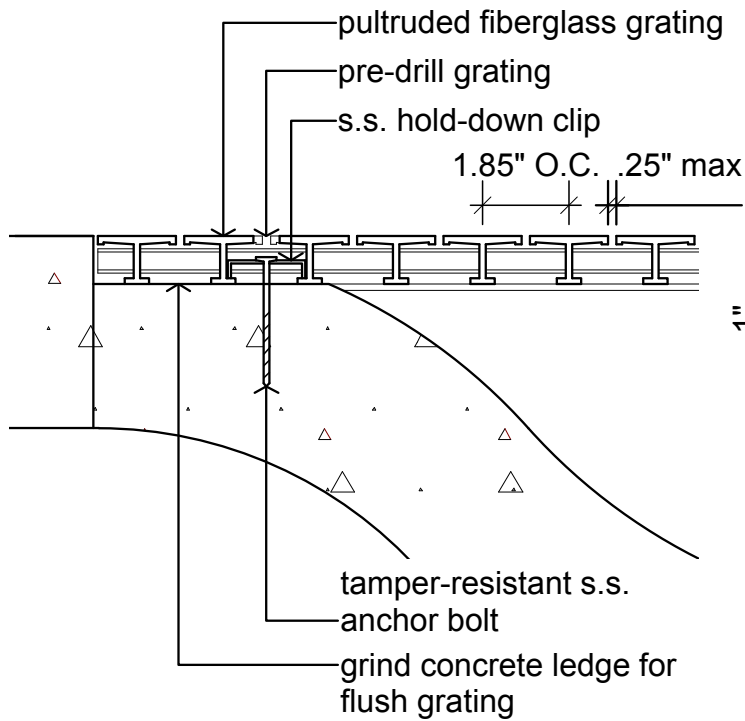
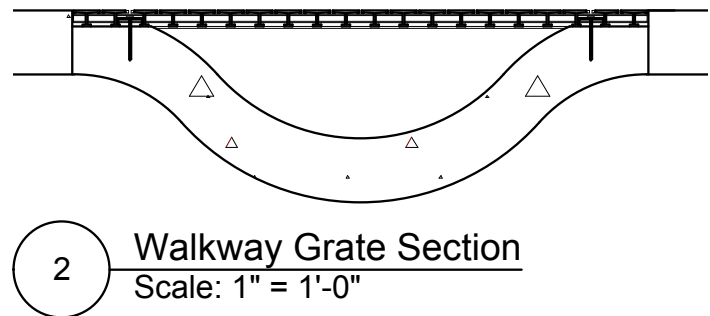
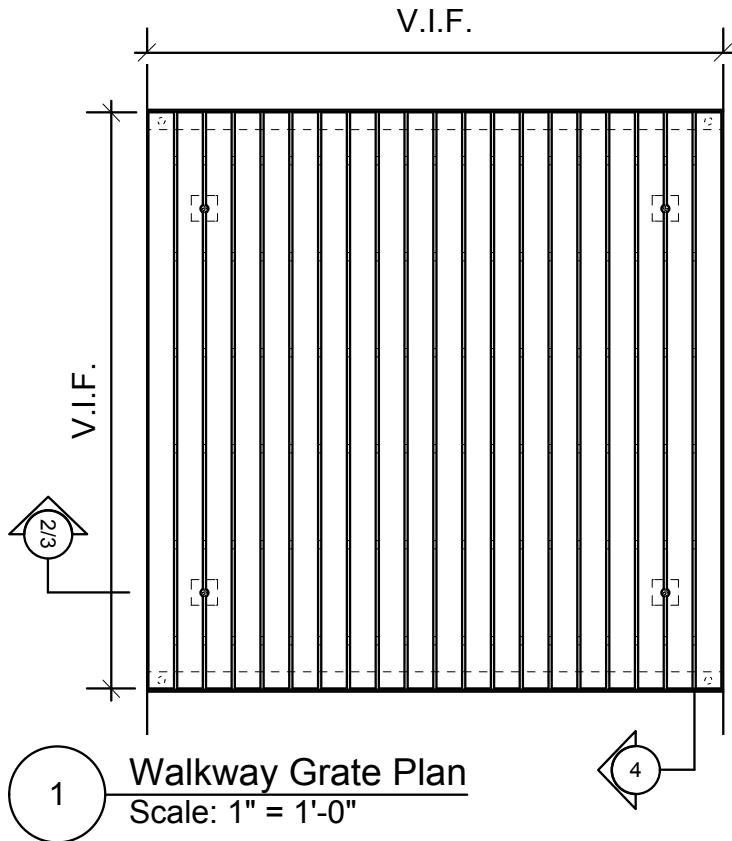

3 Walkway Grate Attachment Detail  
 Scale: 3" = 1'-0"

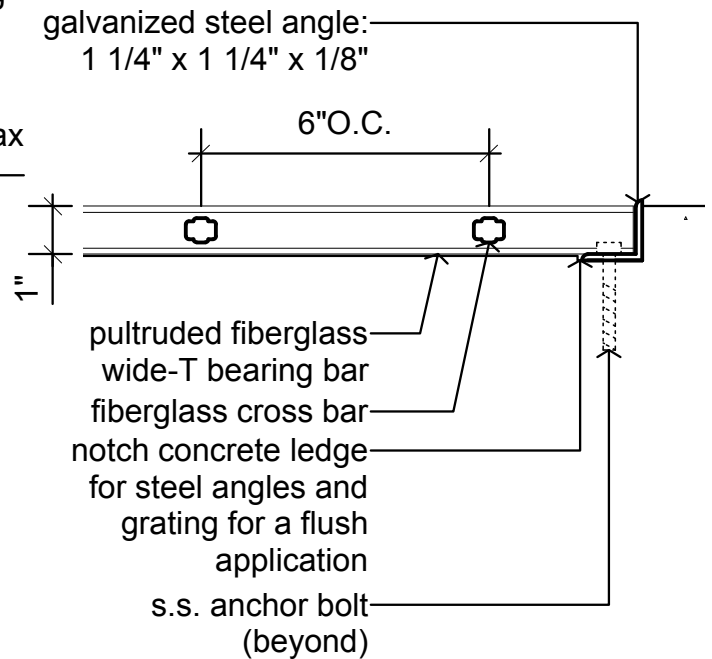

4 Attach to Conc. Grate Detail  
 Scale: 3" = 1'-0"

END OF SECTION 06 61 00

SECTION 09 96 00 – HIGH-PERFORMANCE COATINGS

**PART I: GENERAL**

1. RELATED DOCUMENTS
  - A. Drawings and general provisions of the Contract, including General and Supplementary Conditions and Division 01 Specification Sections, apply to this Section.
1. SUMMARY
  - A. This Section includes surface preparation and the application of paint systems on the following exterior substrate:
    1. Ferrous Metals.
  - B. Related Sections include the following:
    1. Division 5 Sections for shop priming of metal substrates with primers specified in this Section.
3. SUBMITTALS
  - A. Product Data: For each type of product indicated.
  - B. Samples for Initial Selection: For each type of topcoat product indicated.
  - C. Samples for Verification: For each type of paint system and each color and gloss of topcoat indicated.
    1. Submit Samples on rigid backing, 8 inches square.
    2. Step coats on Samples to show each coat required for system.
    3. Label each coat of each Sample.
    4. Label each Sample for location and application area.
4. QUALITY ASSURANCE
  - A. MPI Standards:
    1. Products: Complying with MPI standards indicated and listed in "MPI Approved Products List."
    2. Preparation and Workmanship: Comply with requirements in "MPI Architectural Painting Specification Manual" for products and paint systems indicated.
5. DELIVERY, STORAGE, AND HANDLING
  - A. Store materials not in use in tightly covered containers in well-ventilated areas with ambient temperatures continuously maintained at not less than 45 deg F.
    1. Maintain containers in clean condition, free of foreign materials and residue.
    2. Remove rags and waste from storage areas daily.
6. PROJECT CONDITIONS
  - A. Apply paints only when temperature of surfaces to be painted and ambient air temperatures are between 50 and 95 deg F.
  - B. Do not apply paints in snow, rain, fog, or mist; when relative humidity exceeds 85 percent; at temperatures less than 5 deg F above the dew point; or to damp or wet surfaces
7. EXTRA MATERIALS
  - A. Furnish extra materials described below that are from same production run (batch mix) as materials applied and that are packaged for storage and identified with labels describing contents.
    1. Quantity: Furnish an additional 5 percent, but not less than 1 gal. of each material and color applied.

**PART II: PRODUCTS**

1. MANUFACTURERS
  - A. Manufacturers, Paint for Ferrous Metal Substrates: Subject to compliance with requirements, provide products by the following:
    1. Tnemec or approved equivalent
2. PAINT, GENERAL

- A. Material Compatibility:
    - 1. Provide materials for use within each paint system that are compatible with one another and substrates indicated, under conditions of service and application as demonstrated by manufacturer, based on testing and field experience.
  - B. Colors: Match Architect's samples
3. METAL COATING SYSTEM
- A. Surface Preparation: SSPC SP 6 Commercial Blast Cleaning.
  - B. Basis of design product. Provide the following system or approved equivalent:
    - 1. Primer: Tnemec Series 90-97 Tnemec-Zinc @ 2.5 to 3.5 mils DFT.
    - 2. Intermediate Coat: Tnemec Series N69 Hi-Build Epoxoline II @3.0 to 4.0 mils DFT.
    - 3. Top Coat: Tnemec Series \*1075 Endura-Shield II @ 2.0 to 3.0 mils DFT.

**PART III: EXECUTION**

- 1. EXAMINATION
  - A. Examine substrates and conditions, with Applicator present, for compliance with requirements for maximum moisture content and other conditions affecting performance of work.
  - B. Verify suitability of substrates, including surface conditions and compatibility with existing finishes and primers.
  - C. Begin coating application only after unsatisfactory conditions have been corrected and surfaces are dry.
    - 1. Beginning coating application constitutes Contractor's acceptance of substrates and conditions.
- 2. PREPARATION
  - A. Comply with manufacturer's written instructions and recommendations in "MPI Architectural Painting Specification Manual" applicable to substrates and paint systems indicated.
  - B. Remove plates, machined surfaces, and similar items already in place that are not to be painted. If removal is impractical or impossible because of size and weight of item, provide surface-applied protection before surface preparation and painting.
    - 1. After completing painting operations, use workers skilled in the trades involved to reinstall items that were removed. Remove surface-applied protection if any.
    - 2. Do not paint over labels of independent testing agencies or equipment name, identification, performance rating, or nomenclature plates.
  - C. Clean substrates of substances that could impair bond of paints, including dirt, oil, grease, and incompatible paints and encapsulants.
    - 1. Remove incompatible primers and reprime substrates with compatible primers as required to produce paint systems indicated.
  - D. Ferrous Metal Substrates: Remove rust and loose mill scale. Cleaning using methods recommended in writing by paint manufacturer.
- 3. APPLICATION
  - A. Apply paints according to manufacturer's written instructions.
    - 1. Use applicators and techniques suited for paint and substrate indicated.
    - 2. Paint surfaces behind movable items same as similar exposed surfaces. Before final installation, paint surfaces behind permanently fixed items with prime coats only.
  - B. Tint each undercoat a lighter shade to facilitate identification of each coat if multiple coats of same material are to be applied. Tint undercoats to match color of topcoat, but provide sufficient difference in shade of undercoats to distinguish each separate coat.
  - C. If undercoats or other conditions show through topcoat, apply additional coats until cured film has a uniform paint finish, color, and appearance.

- D. Apply paints to produce surface films without cloudiness, spotting, holidays, laps, brush marks, roller tracking, runs, sags, ropiness, or other surface imperfections. Cut in sharp lines and color breaks.
- 4. FIELD QUALITY CONTROL
  - A. Testing of Paint Materials: Owner reserves the right to invoke the following procedure at any time and as often as Owner deems necessary during the period when paints are being applied:
    - 1. Owner will engage the services of a qualified testing agency to sample paint materials being used. Samples of material delivered to Project site will be taken, identified, sealed, and certified in presence of Contractor.
    - 2. Testing agency will perform tests for compliance of paint materials with product requirements.
    - 3. Owner may direct Contractor to stop applying paints if test results show materials being used do not comply with product requirements. Contractor shall remove noncomplying-paint materials from Project site, pay for testing, and repaint surfaces painted with rejected materials. Contractor will be required to remove rejected materials from previously painted surfaces if, on repainting with complying materials, the two paints are incompatible.
- 5. CLEANING AND PROTECTION
  - A. At end of each workday, remove rubbish, empty can, rags, and other discarded materials from Project site.
  - B. After completing paint application, clean spattered surfaces. Remove spattered paints by washing, scraping, or other methods. Do not scratch or damage adjacent finished surfaces.
  - C. Protect work of other trades against damage from paint application. Correct damage to work of other trades by cleaning, repairing, replacing, and refinishing, as approved by Architect, and leave in an undamaged condition.
  - D. At completion of construction activities of other trades, touch up and restore damaged or defaced painted surfaces.
- 6. HIGH-PERFORMANCE COATING SCHEDULE
  - A. Ferrous Metal Substrates:
    - 1. Tnemec Proprietary System.

END OF SECTION 09 96 00

THIS PAGE BLANK

SECTION 10 14 26 - POST AND PANEL SIGNAGE

**PART I: GENERAL**

1. RELATED DOCUMENTS
  - A. Drawings and general provisions of the Contract, including General and Supplementary Conditions and Division 01 Specification Sections, apply to this Section.
2. SUMMARY
  - A. Section Includes:
    1. Nonilluminated post and panel signs.
  - B. Related Requirements:
    1. Section 01 50 00 "Temporary Facilities and Controls" for temporary Project identification signs and for temporary informational and directional signs.
    2. Section 03 30 00 "Cast-in-Place Concrete" for concrete foundations and concrete fill in postholes.
3. ACTION SUBMITALS
  - A. Contractor to provide signage schedule.
4. COORDINATION
  - A. Furnish templates and tolerance information for placement of sign-anchorage devices embedded in permanent construction by other installers.
5. QUALITY ASSURANCE
  - A. Installer Qualifications: Manufacturer of products or an entity that employs installers and supervisors who are trained and approved by manufacturer.
6. FIELD CONDITIONS
  - A. Field Measurements: Verify locations of anchorage devices embedded in permanent construction by other installers by field measurements before fabrication, and indicate measurements on Shop Drawings.

**PART II: PRODUCTS**

1. PERFORMANCE REQUIREMENTS
  - A. Thermal Movements: For exterior signs, allow for thermal movements from ambient and surface temperature changes.
    1. Temperature Change: 120 deg F, ambient; 180 deg F, material surfaces
  - B. Accessibility Standard: Comply with applicable provisions in the U.S. Architectural & Transportation Barriers Compliance Board's ADA-ABA Accessibility Guidelines for Buildings and Facilities and ICC A117.1 for signs.
  - C. Traffic Control Signage Standards:
    - a. Comply with applicable provisions in the current edition of the U.S. Department of Transportation, Federal Highway Administration's Manual on Uniform Traffic Control Devices, (MUTCD).
    - b. Comply with applicable provisions of the Commonwealth of Pennsylvania Department of Transportation's Bureau of Highway Safety and Traffic Engineering.
2. POST AND PANEL SIGNS
  - A. Post and Panel Signs for traffic control as indicated: Sign with smooth, uniform surfaces; with message and characters having uniform faces, sharp corners, and precisely formed lines and profiles; and as follows:
    1. Solid-Sheet Sign Panels: Aluminum sheet with finish specified in "Sign-Panel-Face Finish and Applied Graphics" Subparagraph below and as follows:

Housing Authority of the City of Pittsburgh  
Authority-wide Site Improvements

- a. Thickness: Manufacturer's standard for size of sign.
    - b. Graphics: 3M Diamond Grade retroreflective graphics complying with MUTCD standards.
  2. Posts: Steel.
    - a. Shape: Round.
    - b. Size: 2 1/2-inch diameter, nominal.
    - c. Top: Fabricate as indicated on drawings.
    - d. Finish and Color: Hot-dip galvanized, acid etched to minimize gloss.
3. MATERIALS
  - A. Aluminum Sheet and Plate: ASTM B 209 , alloy and temper recommended by aluminum producer and finisher for type of use and finish indicated.
  - B. Steel Materials:
    1. Bolts for Steel Framing: ASTM A 307 or ASTM A 325 as necessary for design loads and connection details.
  - C. Paints and Coatings for Sheet Materials: Inks, dyes, and paints that are recommended by manufacturer for optimum adherence to surface and are UV and water resistant for colors and exposure indicated.
4. ACCESSORIES
  - A. Fasteners as indicated on drawings.
5. FABRICATION
  - A. General: Provide manufacturer's standard sign assemblies according to requirements indicated.
    1. Preassemble signs in the shop to greatest extent possible. Disassemble signs only as necessary for shipping and handling limitations. Clearly mark units for reassembly and installation, in locations concealed from view after final assembly.
    2. Mill joints to tight, hairline fit. Form joints exposed to weather to resist water penetration and retention.
    3. Comply with AWS for recommended practices in welding and brazing. Provide welds and brazes behind finished surfaces without distorting or discoloring exposed side. Clean exposed welded and brazed joints of flux, and dress exposed and contact surfaces.
    4. Internally brace signs for stability and for securing fasteners.
  - B. Sign Message Panels: Construct sign-panel surfaces to be smooth and to remain flat under installed conditions within a tolerance of plus or minus 1/16 inch measured diagonally from corner to corner.
    1. Coordinate dimensions and attachment methods to produce message panels with closely fitting joints.
    2. Increase panel thickness or reinforce with concealed stiffeners or backing materials as needed to produce surfaces without distortion, buckles, warp, or other surface deformations.
    3. Continuously weld joints and seams unless other methods are indicated; grind, fill, and dress welds to produce smooth, flush, exposed surfaces with welds invisible after final finishing.



- C. Post Fabrication: Fabricate posts designed to withstand wind pressure indicated for Project location and of lengths required for installation method indicated for each sign.
    - 1. Steel Posts: Fabricate from minimum 0.120-inch-thick steel tubing unless otherwise indicated. Include post caps, fillers, spacers, access panels, reinforcement where required for loading conditions, and related accessories required for complete installation.
      - a. Hot-dip galvanize post assemblies after fabrication according to ASTM A 123/A 123M.
6. GENERAL FINISH REQUIREMENTS
- A. Protect mechanical finishes on exposed surfaces from damage by applying a strippable, temporary protective covering before shipping.
  - B. Appearance of Finished Work: Noticeable variations in same piece are not acceptable. Variations in appearance of adjoining components are acceptable if they are within the range of approved Samples and are assembled or installed to minimize contrast.

**PART III: EXECUTION**

- 1. EXAMINATION
  - A. Examine substrates, areas, and conditions, with Installer present, for compliance with requirements for installation tolerances and other conditions affecting performance of signage work.
  - B. Verify that sign-support surfaces are within tolerances to accommodate signs.
  - C. Verify that anchor inserts are correctly sized and located to accommodate signs.
  - D. Proceed with installation only after unsatisfactory conditions have been corrected.
- 2. INSTALLATION
  - A. General: Install signs using installation methods indicated and according to manufacturer's written instructions.
    - 1. Install signs level, plumb, and at locations and heights indicated, with sign surfaces free of distortion and other defects in appearance.
    - 2. Install signs so they do not protrude or obstruct according to accessibility and DOT standards.
    - 3. Before installation, verify that sign components are clean and free of materials or debris that would impair installation.
- 3. INSTALLING POSTS
  - A. Vertical Tolerance: Set posts plumb within a tolerance of 1/16 inch in 3 feet.
- 4. ADJUSTING AND CLEANING
  - A. Remove and replace damaged or deformed signs and signs that do not comply with specified requirements. Replace signs with damaged or deteriorated finishes or components that cannot be successfully repaired by finish touchup or similar minor repair procedures.
  - B. Remove temporary protective coverings and strippable films as signs are installed.
  - C. On completion of installation, clean exposed surfaces of signs according to manufacturer's written instructions, and touch up minor nicks and abrasions in finish. Maintain signs in a clean condition during construction and protect from damage until acceptance by Owner.

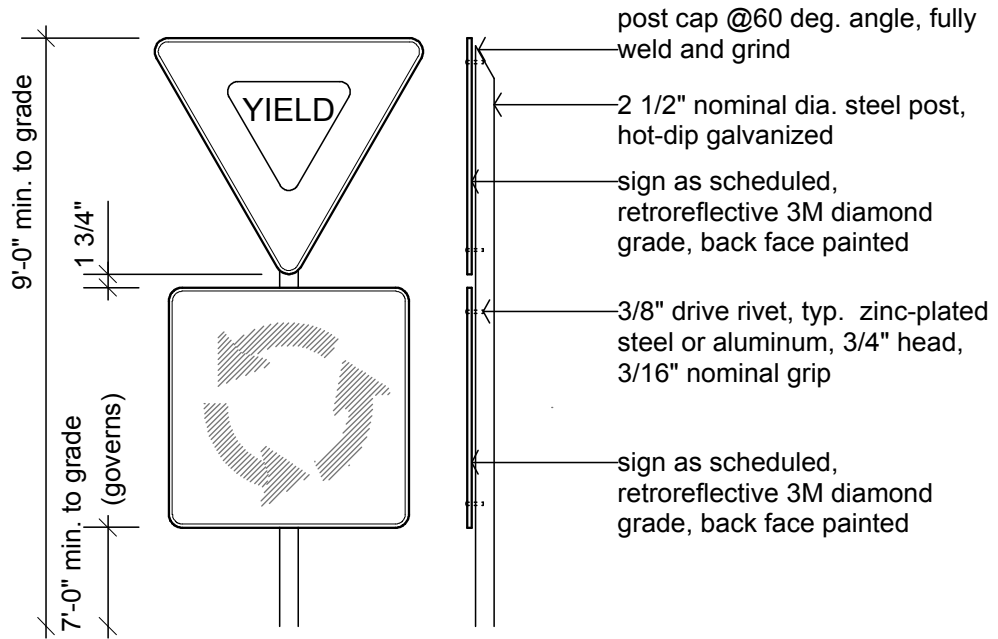

1 **Post and Panel Signs**  
 Scale: 1/2" = 1'-0"

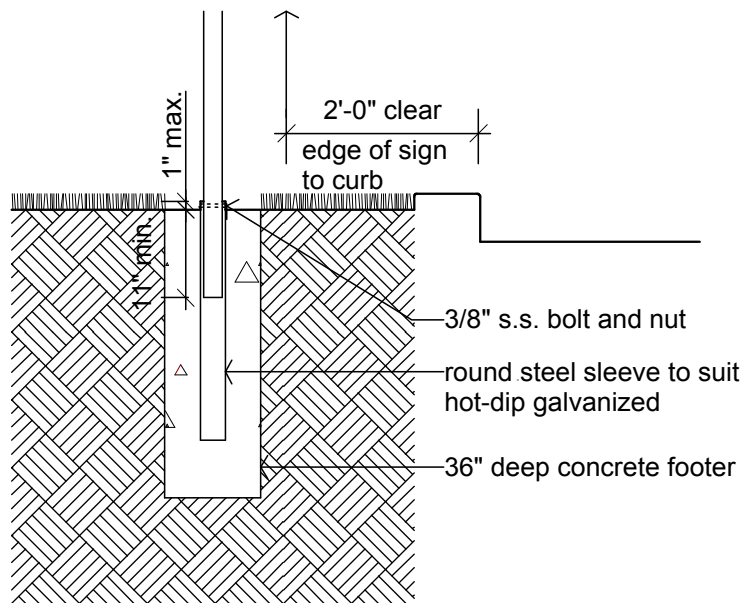

2 **Post and Panel Sign Base**  
 Scale: 1/2" = 1'-0"

END OF SECTION 10 14 26

SECTION 10 75 00 - FLAGPOLES

**PART I: GENERAL**

1. RELATED DOCUMENTS
  - A. Drawings and general provisions of the Contract, including General and Supplementary Conditions and Division 01 Specification Sections, apply to this Section.
2. SUMMARY
  - A. Section includes ground-mounted flagpoles made from aluminum or stainless steel, based on selected alternate.
  - B. Flags.
  - C. Related Sections:
    1. Section 03 30 00 "Cast-in-Place Concrete."
    2. Section 26 56 00 "Exterior Lighting" for site lighting fixtures.
3. PERFORMANCE REQUIREMENTS
  - A. Structural Performance: Flagpole assemblies, including anchorages and supports, shall withstand the effects of gravity loads, and the following loads and stresses within limits and under conditions indicated according to the following design criteria:
    1. Wind Loads: Wind speed and exposure factor according to NAAMM FP 1001, "Guide Specifications for Design of Metal Flagpoles."
    2. Base flagpole design on nylon flags of maximum standard size suitable for use with flagpole or flag size indicated, whichever is more stringent.
4. ACTION SUBMITTALS
  - A. Product Data: For each type of product indicated. Include construction details, material descriptions, dimensions of individual components and profiles, operating characteristics, fittings, accessories, and finishes for flagpoles.
  - B. Shop Drawings: For flagpoles. Include plans, elevations, details, and attachments to other work. Show general arrangement, jointing, fittings, accessories, grounding, anchoring, and support.
    1. Include section, and details of foundation system for ground-mounted flagpoles.
5. CLOSEOUT SUBMITTALS
  - A. Operation and Maintenance Data: For flagpoles to include in operation and maintenance manuals.
6. QUALITY ASSURANCE
  - A. Source Limitations: Obtain flagpole as complete unit, including fittings, accessories, bases, and anchorage devices, from single source from single manufacturer.
7. DELIVERY, STORAGE, AND HANDLING
  - A. General: Spiral wrap flagpoles with heavy paper and enclose in a hard fiber tube or other protective container.

**PART II: PRODUCTS**

1. FLAG MANUFACTURERS
  - A. Obtain flags from one of the following manufacturers:
    1. Annin and Co. Flagmakers.
    2. CF Flag Company.
    3. Valley Forge Flag Company, Inc.
2. FLAGPOLE MANUFACTURERS

Housing Authority of the City of Pittsburgh  
Authority-wide Site Improvements

- A. Manufacturers: Subject to compliance with requirements, available manufacturers offering products that may be incorporated into the Work include, but are not limited to, the following:
  1. American Flagpole; a Kearney-National Inc. company.
  2. Baartol Company.
  3. Concord Industries, Inc.
  4. Eder Flag Manufacturing Company, Inc.
  5. Ewing Flagpoles.
  6. Lingo Inc.; Acme Flagpole Company Division.
  7. Millerbernd Manufacturing Company.
  8. Morgan-Francis; Division of Original Tractor Cab Co., Inc.
  9. Pole-Tech Company Inc.
  10. U.S. Flag & Flagpole Supply, LP.
  11. USS Manufacturing Inc.
3. FLAGS
  - A. Flag of the United States of America: Nylon, canvas heading, brass grommets, long dimension of flag shall be at least  $\frac{1}{4}$  of height of flagpole above ground.
    1. Flag Etiquette: For information about rules on handling and displaying the U.S. flag, see <http://www.gpoaccess.gov/uscode/browse.html> and click on Title 4, Chapter 1.
4. FLAGPOLES
  - A. Flagpole Construction, General: Construct flagpoles in one piece if possible. If more than one piece is necessary, comply with the following:
    1. Fabricate shop and field joints without using fasteners, screw collars, or lead caulking.
    2. Provide flush hairline joints using self-aligning, snug-fitting, internal sleeves.
    3. Provide self-aligning, snug-fitting joints.
  - B. Exposed Height: As indicated.
  - C. Aluminum Flagpoles: Provide cone-tapered flagpoles fabricated from seamless extruded tubing complying with ASTM B 241/B 241M, Alloy 6063, with a minimum wall thickness of  $\frac{3}{16}$  inch.
  - D. Metal Foundation Tube: Manufacturer's standard corrugated-steel foundation tube, not less than 0.064-inch- nominal wall thickness. Provide with  $\frac{3}{16}$ -inch steel bottom plate and support plate;  $\frac{3}{4}$ -inch-diameter, steel ground spike; and steel centering wedges welded together. Galvanize steel after assembly. Provide loose hardwood wedges at top of foundation tube for plumbing pole.
    1. Provide flashing collar of same material and finish as flagpole.
5. FITTINGS
  - A. External Halyard: Ball-bearing, nonfouling, revolving truck assembly of cast metal with continuous  $\frac{5}{16}$ -inch- diameter, braided polypropylene halyard and 9-inch cast-metal cleats with fasteners. Finish exposed metal surfaces to match flagpole.
    1. Provide one halyard and one cleat at flagpole.
    2. Plastic Halyard Flag Clips: made from injection-molded, UV-stabilized, acetal resin (Delrin). Clips attached to flag and have two eyes for inserting halyard run. Provide flag clips in quantity required for flags indicated.

- a. Product: Subject to compliance with requirements, provide “Quiet Halyard” flag clasp by Lingo.
3. Provide a halyard lock per flagpole.
6. MISCELLANEOUS MATERIALS
  - A. Drainage Material: Crushed stone, or crushed or uncrushed gravel; coarse aggregate.
  - B. Sand: ASTM C 33, fine aggregate.
  - C. Elastomeric Joint Sealant: Multicomponent nonsag urethane, or Single-component nonsag urethane, or Single-component neutral- and basic-curing silicone, or Single-component neutral-curing silicone joint sealant complying with requirements in Section 07 92 00 “Joint Sealants” for Use NT (nontraffic) and for Use M, G, A, and, as applicable to joint substrates indicated, for use O.
  - D. Bituminous Paint: Cold-applied asphalt emulsion complying with ASTM D 1187.
7. GENERAL FINISH REQUIREMENTS
  - A. Comply with NAAMM’s “Metal Finishes Manual for Architectural and Metal products” for recommendations for applying and designating finishes.
  - B. Appearance of Finished Work: Noticeable variations in same piece are not acceptable. Variations in appearance of adjoining components are acceptable if they are within the range of approved Samples and are assembled or installed to minimize contrast.
8. ALUMIINUM FINISHES
  - A. Clear Anodic Finish: AAMA 611, AA-M12C22A41, Class I, 0.018 mm or thicker.

**PART III: EXECUTION**

1. EXAMINATION
  - A. Examine substrates, areas, and conditions, with Installer present, for compliance with requirements for installation tolerances, including foundation; accurate placement, pattern, orientation of anchor bolts, and other conditions affecting performance of the Work.
  - B. Proceed with installation only after unsatisfactory conditions have been corrected.
2. PREPARATION
  - A. Prepare uncoated metal flagpoles that are set in foundation tubes by painting below-grade portions with a heavy coat of bituminous paint.
  - B. Foundation Excavation: Excavate to neat clean lines in undisturbed soil. Remove loose soil and foreign matter from excavation and moisten earth before placing concrete. Place and compact drainage material at excavation bottom.
  - C. Provide forms where required due to unstable soil conditions and for perimeter of flagpole base at grade. Secure and brace forms to prevent displacement during concreting.
  - D. Place concrete, as specified in Section 03 30 00 “Cast-in-Place Concrete.” Compact concrete in place by using vibrators. Moist-cure exposed concrete for not less than seven days or use nonstaining curing compound.
  - E. Trowel exposed concrete surfaces to a smooth, dense finish, free of trowel marks, and uniform in texture and appearance. Provide positive slope for water runoff to perimeter of concrete base.
3. FLAGPOLE INSTALLATION
  - A. General: Install flagpole where shown and according to Shop Drawings and manufacturer’s written instructions.

Housing Authority of the City of Pittsburgh  
Authority-wide Site Improvements

- B. Ground Set: Place foundation tube, center, and brace to prevent displacement during concreting. Place concrete. Plumb and level foundation tube and allow concrete to cure. Install flagpole, plumb, in foundation tube.
  - 1. Foundation Tube: Place tube seated on bottom plate between steel centering wedges and install hardwood wedges to secure flagpole in place. Place and compact sand in foundation tube and remove hardwood wedges. Seal top of foundation tube with a 2-inch layer of elastomeric joint sealant and cover with flashing collar.
- 4. FLAG INSTALLATION
  - A. Deliver flags to Owner, unopened, in manufacturer's original packaging.

END OF SECTION 10 75 00

**SECTION 31 11 00 – CLEARING AND GRUBBING**

**ITEM 31 11 00.2011 CLEARING AND GRUBBING: TOPSOIL REMOVAL, STOCKPILE AND DISPOSAL**

**ITEM 31 11 00.2012 CLEARING AND GRUBBING: TOPSOIL AND ORGANIC MATTER REMOVAL, STOCKPILE AND DISPOSAL**

**ITEM 31 11 00.2013 CLEARING AND GRUBBING: OBJECTIONABLE MATERIAL REMOVAL AND DISPOSAL**

**PART I: DESCRIPTION**

- A. 2011 – Clearing and grubbing of the first 8” of topsoil and organic material, stockpiling of topsoil material, obtaining of waste areas for disposal of materials and disposal of removed material within the project limits as directed.
- B. 2012 – Clearing and grubbing of ground of obstructions including: removal of topsoil and organic matter such as trees, stumps, brush roots and other vegetation; chipping and stockpiling wood waste material, stockpiling of topsoil material, obtaining of waste areas for disposal of materials and disposal of removed material within the project limits as directed.
- C. 2013 – Clearing and grubbing of ground of obstructions including; removal of objectionable material, rubbish and junk, buildings and structures, fences, walls, guide rail posts, guide rails, signs, direction markers, and other obstructions interfering with the work, obtaining of waste areas for disposal of materials and disposal of removed material within the project limits as directed.

**PART II: GENERAL**

- A. When ordered by Director, clear and grub in accordance with Director’s instructions as determined in the field and the applicable Sections of City of Pittsburgh Specifications.
- B. Clear and grub per City of Pittsburgh Specification Section 404, and other applicable sections of City of Pittsburgh Specifications.
- C. Clearing and grubbing as specified in PADOT Publication 408, Section 201 – Clearing and Grubbing. Conform PADOT specifications to applicable sections of City of Pittsburgh Specifications.

**PART III: PRODUCTS AND MATERIALS [NOT USED]**

**PART IV: CONSTRUCTION AND EXECUTION**

- A. Execute work as specified in PADOT 408, Section 201.3 Construction .

**PART V: MEASUREMENT AND PAYMENT**

- A. **CLEARING AND GRUBBING: TOPSOIL REMOVAL, STOCKPILE AND DISPOSAL. Square Yard.**

**CLEARING AND GRUBBING: TOPSOIL AND ORGANIC MATTER REMOVAL, STOCKPILE AND DISPOSAL. Square Yard.**

**CLEARING AND GRUBBING: OBJECTIONABLE MATERIAL REMOVAL  
AND DISPOSAL. Square Yard.**

1. Payment will be made at the Unit Price Bid per square yard of clearing and grubbing.
2. Payment is full compensation for the work described for the item, including all necessary labor, tools, machinery, and materials required to complete the work.

END OF SECTION 31 11 00



**SECTION 31 12 00 – SELECTIVE CLEARING**

**ITEM 31 12 00.8101 REMOVE TREE STUMP, EQUAL TO OR LESS THAN 12"**

**ITEM 31 12 00.8102 REMOVE TREE STUMP, GREATER THAN 12" AND EQUAL TO OR LESS THAN 24"**

**ITEM 31 12 00.8103 GRIND TREE STUMP**

**PART I: DESCRIPTION**

- A. 8101 – Removal of select tree stump, equal to or less than 12" in diameter, placement of fill to grade and the removal of debris.
- B. 8102 – Removal of select tree stump, greater than 12" in diameter and less than or equal to 24" in diameter, placement of fill to grade and the removal of debris.
- C. 8103 – Grind tree stump to 9" below grade, placement of fill to grade and the removal of debris.

**PART II: GENERAL**

- A. When ordered by Director, trim tree, remove tree, remove stump or grind stump in accordance with Director's instructions as determined in the field and the applicable Sections of City of Pittsburgh Specifications.
- B. Trees per City of Pittsburgh Specification Section 552, and other applicable sections of City of Pittsburgh Specifications.
- C. Tree trimming and selective tree removal as specified in PADOT Publication 408, Section 810 – Tree Trimming and Selective Tree Removal. Conform PADOT specifications to applicable sections of City of Pittsburgh Specifications.

**PART III: PRODUCTS AND MATERIALS [NOT USED]**

**PART IV: CONSTRUCTION AND EXECUTION [NOT USED]**

**PART V: MEASUREMENT AND PAYMENT**

- A. REMOVE TREE STUMP, EQUAL TO OR LESS THAN 12". Each.**  
**REMOVE TREE STUMP, GREATER THAN 12" AND EQUAL TO OR LESS THAN 24". Each.**
  - 1. Payment will be made at the Unit Price Bid per each tree stump and root ball removed a minimum of 4' below grade and disposed.
  - 2. Payment is full compensation for the work described for the item, including all necessary labor, tools, machinery, and materials required to complete the work.
- B. GRIND TREE STUMP. Square Inch.**
  - 1. Payment will be made at the Unit Price Bid per square inch of stump diameter, ground from 4" above grade to 9" below grade.
  - 2. Payment is full compensation for the work described for the item, including all necessary labor, tools, machinery, and materials required to complete the work.

END OF SECTION 31 12 00

[THIS PAGE BLANK]

**SECTION 31 13 13 – SELECTIVE TREE AND SHRUB REMOVAL**

**ITEM 31 13 13.8120 REMOVE TREE, EQUAL TO OR LESS THAN 12"**

**ITEM 31 13 13.8121 REMOVE TREE, GREATER THAN 12" AND EQUAL TO OR LESS THAN 24"**

**ITEM 31 13 13.8122 REMOVE TREE, GREATER THAN 24"**

**PART I: DESCRIPTION**

- A. 8210 – Removal of select trees, equal to or less than 12" in diameter, and the removal of debris.
- B. 8221 – Removal of select trees, greater than 12" in diameter and equal to or less than 24" in diameter, and the removal of debris.
- C. 8232 – Removal of select trees, greater than 24" in diameter, and the removal of debris.

**PART II: GENERAL**

- A. When ordered by Director, trim tree, remove tree, remove stump or grind stump in accordance with Director's instructions as determined in the field and the applicable Sections of City of Pittsburgh Specifications.
- B. Trees per City of Pittsburgh Specification Section 552, and other applicable sections of City of Pittsburgh Specifications.
- C. Tree trimming and selective tree removal as specified in PADOT Publication 408, Section 810 – Tree Trimming and Selective Tree Removal. Conform PADOT specifications to applicable sections of City of Pittsburgh Specifications.

**PART III: PRODUCTS AND MATERIALS [NOT USED]**

**PART IV: CONSTRUCTION AND EXECUTION [NOT USED]**

**PART V: MEASUREMENT AND PAYMENT**

**A. REMOVE TREE, EQUAL TO OR LESS THAN 12". Each.**

**REMOVE TREE, GREATER THAN 12" AND EQUAL TO OR LESS THAN 24".**

**Each**

**REMOVE TREE, GREATER THAN 24". Each.**

1. Payment will be made at the Unit Price Bid per each tree removed to the ground line or a height not more than 4" above grade and disposed.
2. Payment is full compensation for the work described for the item, including all necessary labor, tools, machinery, and materials required to complete the work.

END OF SECTION 31 13 13

[THIS PAGE BLANK]

**SECTION 31 13 16 – SELECTIVE TREE AND SHRUB TRIMMING**

**ITEM 31 13 16.8110 TREE TRIMMING, LESS THAN 20'**

**ITEM 31 13 16.8111 TREE TRIMMING, GREATER THAN 20'**

**PART I: DESCRIPTION**

- A. 8110 – Select trimming of trees and shrubs, less than 20' in height, and the removal and disposal of debris.
- B. 8111 – Select trimming of trees, greater than 20' in height, and the removal of debris.

**PART II: GENERAL**

- A. When ordered by Director, trim tree, remove tree, remove stump or grind stump in accordance with Director's instructions as determined in the field and the applicable Sections of City of Pittsburgh Specifications.
- B. Trees per City of Pittsburgh Specification Section 552, and other applicable sections of City of Pittsburgh Specifications.
- C. Tree trimming and selective tree removal as specified in PADOT Publication 408, Section 810 – Tree Trimming and Selective Tree Removal. Conform PADOT specifications to applicable sections of City of Pittsburgh Specifications.

**PART III: PRODUCTS AND MATERIALS [NOT USED]**

**PART IV: CONSTRUCTION AND EXECUTION [NOT USED]**

**PART V: MEASUREMENT AND PAYMENT**

**A. TREE TRIMMING, LESS THAN 20'. Each.**

**TREE TRIMMING, GREATER THAN 20'. Each.**

- 1. Payment will be made at the Unit Price Bid per each tree trimmed and debris removed and disposed.
- 2. Payment is full compensation for the work described for the item, including all necessary labor, tools, machinery, and materials required to complete the work.

END OF SECTION 31 13 16

[THIS PAGE BLANK]

**SECTION 31 22 16 – FINE GRADING**

**ITEM 31 22 16.0203 GRADING, EMBANKMENT AND SPOIL**

**PART I: DESCRIPTION**

- A. 0203 – Formation for subgrade including; disposal of all material excavated from the site above finished subgrade elevation and the placement of material in embankments to finished subgrade for roadways, sidewalks and slopes.

**PART II: GENERAL**

- A. When ordered by Director, excavate, grade and dispose of material to form subgrade, in accordance with Director's instructions as determined in the field and the applicable Sections of City of Pittsburgh Specifications.
- B. Grading per City of Pittsburgh Specification Section 1204 including Sections 405, 408 and 409, and other applicable sections of City of Pittsburgh Specifications.

**PART III: PRODUCTS AND MATERIALS [NOT USED]**

**PART IV: CONSTRUCTION AND EXECUTION [NOT USED]**

**PART V: MEASUREMENT AND PAYMENT**

**A. GENERAL EXCAVATION AND SPOIL. Cubic Yard.**

- 1. Payment will be made at the Unit Price Bid per cubic yard of excavation for the formation of subgrade.
- 2. Payment is full compensation for the work described for the item, including all necessary labor, tools, machinery, and materials required to complete the work.

END OF SECTION 31 22 16

[THIS PAGE BLANK]



**SECTION 31 23 13 – SUBGRADE PREPARATION**

**ITEM 31 23 13.0414 SUBGRADE PREPARATION**

**PART I: DESCRIPTION**

- A. 0414 – Preparation of an existing subgrade after removal of subbase material.

**PART II: GENERAL**

- A. When ordered by Director, prepare subgrade, in accordance with Director's instructions as determined in the field and the applicable Sections of City of Pittsburgh Specifications. The extent of subgrade preparation is to conform to the orders of the Director given in the field.
- B. Preparation of subgrade per City of Pittsburgh Specification Sections 414 for subgrade preparation and other applicable sections of City of Pittsburgh Specifications.

**PART III: PRODUCTS AND MATERIALS [NOT USED]**

**PART IV: CONSTRUCTION AND EXECUTION [NOT USED]**

**PART V: MEASUREMENT AND PAYMENT**

**A. SUBGRADE PREPARATION. Square Yard.**

1. Payment will be made at the Unit Price Bid per square yard for subgrade preparation.
2. Payment is full compensation for the work described for the item, including all necessary labor, tools, machinery, and materials required to complete the work.

END OF SECTION 31 23 13

[THIS PAGE BLANK]

**SECTION 31 23 16 – EXCAVATION**

**ITEM 31 23 16.0403 GENERAL EXCAVATION AND SPOIL**

**PART I: DESCRIPTION**

- A. 0403 – No Classification for material to be excavated, regardless of the character and kind of materials encountered, or of the number, location and kind of structures or substructures encountered and the disposal of all material from excavation not required for subgrade and grade from the site.

**PART II: GENERAL**

- A. When ordered by Director, excavate and dispose of material, in accordance with Director's instructions as determined in the field and the applicable Sections of City of Pittsburgh Specifications.
- B. General excavation and spoil per City of Pittsburgh Specification Sections 403 and Sections 408 and other applicable sections of City of Pittsburgh Specifications.

**PART III: PRODUCTS AND MATERIALS [NOT USED]**

**PART IV: CONSTRUCTION AND EXECUTION [NOT USED]**

**PART V: MEASUREMENT AND PAYMENT**

**A. GENERAL EXCAVATION AND SPOIL. Cubic Yard.**

- 1. Payment will be made at the Unit Price Bid per cubic yard for excavation.
- 2. Payment is full compensation for the work described for the item, including all necessary labor, tools, machinery, and materials required to complete the work.

**ITEM 31 23 16.0456 DITCHING**

**PART I: DESCRIPTION**

- A. 0456 – Excavation for channels or modifications to channels to existing or proposed inlets and alongside of roadways including the disposal of all material from excavation not required for subgrade and grade from the site.

**PART II: GENERAL**

- A. When ordered by Director, excavate, in accordance with Director’s instructions as determined in the field and the applicable Sections of City of Pittsburgh Specifications.
- B. Ditching per City of Pittsburgh Specification Section 1221 and other applicable sections of City of Pittsburgh Specifications.

**PART III: PRODUCTS AND MATERIALS [NOT USED]**

**PART IV: CONSTRUCTION AND EXECUTION [NOT USED]**

**PART V: MEASUREMENT AND PAYMENT**

**A. DITCHING. Cubic Yard.**

- 1. Payment will be made at the Unit Price Bid per cubic yard for ditching excavation.
- 2. Payment is full compensation for the work described for the item, including all necessary labor, tools, machinery, and materials required to complete the work.

END OF SECTION 31 23 16

**SECTION 31 23 23 – FILL**

**ITEM 31 23 23.0407 BORROW**

**PART I: DESCRIPTION**

- A. 0407 – Additional material from external sources required for the purpose of fill or embankment from the ground surface or bottom of excavated unsuitable material to the finished subgrade.

**PART II: GENERAL**

- A. When ordered by Director, furnish and place borrow material, in accordance with Director's instructions as determined in the field and the applicable Sections of City of Pittsburgh Specifications.
- B. Borrow material per City of Pittsburgh Specification Sections 407 and other applicable sections of City of Pittsburgh Specifications.

**PART III: PRODUCTS AND MATERIALS [NOT USED]**

**PART IV: CONSTRUCTION AND EXECUTION [NOT USED]**

**PART V: MEASUREMENT AND PAYMENT**

**A. BORROW. Cubic Yard.**

1. Payment will be made at the Unit Price Bid per cubic yard of borrow material furnished and installed.
2. Payment is full compensation for the work described for the item, including all necessary labor, tools, machinery, and materials required to complete the work.

END OF SECTION 31 23 23

[THIS PAGE BLANK]

**SECTION 31 23 33 – TRENCHING AND BACKFILLING**

**ITEM 31 23 33.0425 TRENCH EXCAVATION**

**PART I: DESCRIPTION**

- A. 0425 – Excavation for structures including retaining walls, abutments and footings for a depth not to exceed ten (10') feet and the disposal of all material from excavation not required for subgrade and grade from the site.

**PART II: GENERAL**

- A. When ordered by Director, excavate, in accordance with Director's instructions as determined in the field and the applicable Sections of City of Pittsburgh Specifications.
- B. Trench Excavation per City of Pittsburgh Specification Sections 1209 and Sections 425 to 429, inclusive for Trench Excavation and other applicable sections of City of Pittsburgh Specifications.

**PART III: PRODUCTS AND MATERIALS [NOT USED]**

**PART IV: CONSTRUCTION AND EXECUTION [NOT USED]**

**PART V: MEASUREMENT AND PAYMENT**

**A. TRENCH EXCAVATION. Cubic Yard.**

- 1. Payment will be made at the Unit Price Bid per cubic yard for trench excavation.
- 2. Payment is full compensation for the work described for the item, including all necessary labor, tools, machinery, and materials required to complete the work.

**ITEM 31 23 33.0430 SEWER EXCAVATION**

**PART I: DESCRIPTION**

- A. 0430 – Excavation for storm and sanitary sewers, catch basins, inlets manholes and other associated structures and the disposal of all material from excavation not required for subgrade or grade from the site.

**PART II: GENERAL**

- A. When ordered by Director, excavate, in accordance with Director’s instructions as determined in the field and the applicable Sections of City of Pittsburgh Specifications.
- B. Sewer excavation per City of Pittsburgh Specification Sections 430 to 454 inclusive for Excavating, back filling and repaving for sewers and other applicable sections of City of Pittsburgh Specifications.

**PART III: PRODUCTS AND MATERIALS [NOT USED]**

**PART IV: CONSTRUCTION AND EXECUTION [NOT USED]**

**PART V: MEASUREMENT AND PAYMENT**

**A. SEWER EXCAVATION. Cubic Yard.**

- 1. Payment will be made at the Unit Price Bid per cubic yard for sewer excavation.
- 2. Payment is full compensation for the work described for the item, including all necessary labor, tools, machinery, and materials required to complete the work.

END OF SECTION 31 23 33



**SECTION 32 01 16 – FLEXIBLE PAVING REHABILITATION**

**ITEM 32 01 16.0491 MILL BITUMINOUS SURFACE**

**PART I: DESCRIPTION**

- A. 0491 – Milling of bituminous pavement surface, 1 1/2" Depth.

**PART II: GENERAL**

- A. When ordered by Director, mill existing bituminous pavement surface, in accordance with Director's instructions as determined in the field and the applicable Sections of City of Pittsburgh Specifications. The extent of milling is to conform to the orders of the Director given in the field.
- B. Mill Bituminous Surface as specified in PADOT Publication 408, Section 491 – Milling of Bituminous Pavement Surface. Conform PADOT specifications to applicable sections of City of Pittsburgh Specifications.

**PART III: PRODUCTS AND MATERIALS [NOT USED]**

**PART IV: CONSTRUCTION AND EXECUTION**

- A. Execute work as specified in PADOT 408, Section 491.3 Construction.

**PART V: MEASUREMENT AND PAYMENT**

**A. MILL BITUMINOUS SURFACE. Square Yard.**

1. Payment will be made at the Unit Price Bid per square yard bituminous material milled.
2. Payment is full compensation for the work described for the item, including all necessary labor, tools, machinery, and materials required to complete the work.

END OF SECTION 32 01 16

[THIS PAGE BLANK]

**SECTION 32 01 17 – FLEXIBLE PAVING REPAIR**

**ITEM 32 01 17.0324 MANUAL BITUMINOUS PATCHING, WEARING COURSE**

**ITEM 32 01 17.2300 MANUAL BITUMINOUS PATCHING, BINDER COURSE**

**PART I: DESCRIPTION**

- A. 0324 – Superpave Asphalt Mixture Design, HMA Wearing Course, Manual Patching, PG 64-22, <0.3 Million ESALS, 9.5 MM Mix, SRL-M, for preparing and patching of potholes, abrupt depressions, and deteriorated edges of pavement, and repatching temporarily patched potholes.
- B. 2300 – Superpave Asphalt Mixture Design, HMA Binder Course, Manual Patching, PG 64-22, <0.3 Million ESALS, 19 MM Mix, for preparing and patching of potholes, abrupt depressions, and deteriorated edges of pavement, and repatching temporarily patched potholes.

**PART II: GENERAL**

- A. When ordered by Director, furnish and install bituminous patching material, in accordance with Director's instructions as determined in the field and the applicable Sections of City of Pittsburgh Specifications.
- B. The extent and location of the patching is to conform to the orders of the Director given in the field.
- C. Manual Bituminous Patching as specified in PADOT Publication 408, Section 450 – Manual Bituminous Patching. Conform PADOT specifications to applicable sections of City of Pittsburgh Specifications.

**PART III: PRODUCTS AND MATERIALS**

- A. Provide products and materials specified in PADOT 408, Section 450.2 Material or approved type.

**PART IV: CONSTRUCTION AND EXECUTION**

- A. Execute work as specified in PADOT 408, Section 450.3 Construction.

**PART V: MEASUREMENT AND PAYMENT**

- A. **MANUAL BITUMINOUS PATCHING, WEARING COURSE. Ton.**
  - 1. Payment will be made at the Unit Price Bid per ton of bituminous material for preparing and patching furnished and installed.
  - 2. Payment is full compensation for the work described for the item, including all necessary labor, tools, machinery, and materials required to complete the work.
- B. **MANUAL BITUMINOUS PATCHING, BINDER COURSE. Ton.**
  - 1. Payment will be made at the Unit Price Bid per ton of bituminous material for preparing and patching furnished and installed.
  - 2. Payment is full compensation for the work described for the item, including all necessary labor, tools, machinery, and materials required to complete the work.

END OF SECTION 32 01 17

[THIS PAGE BLANK]

**SECTION 32 01 26 – RIGID PAVING REHABILITATION**

**ITEM 32 01 26.0514 GRINDING OF CONCRETE PAVEMENT, SIDEWALK**

**PART I: DESCRIPTION**

- A. 0514 – Diamond grinding of concrete pavement for compliance with Uniform Federal Accessibility Standards (UFAS) for residential facilities covered by HUD's standards and ADA and ABA Accessibility Guidelines.

**PART II: GENERAL**

- A. When ordered by Director, grind concrete pavement, in accordance with Director's instructions as determined in the field and the applicable Sections of City of Pittsburgh Specifications. The extent of grinding is to conform to the orders of the Director given in the field.
- B. Grinding of Concrete Pavement as specified in PADOT Publication 408, Section 514 – Diamond Grinding of Concrete Pavement. Conform PADOT specifications to applicable sections of City of Pittsburgh Specifications.

**PART III: PRODUCTS AND MATERIALS [NOT USED]**

**PART IV: CONSTRUCTION AND EXECUTION**

- A. Execute work as specified in PADOT 408, Section 514.3 Construction.

**PART V: MEASUREMENT AND PAYMENT**

- A. **GRINDING OF CONCRETE PAVEMENT, SIDEWALK. Square Yard.**
  - 1. Payment will be made at the Unit Price Bid per square yard of concrete pavement ground.
  - 2. Payment is full compensation for the work described for the item, including all necessary labor, tools, machinery, and materials required to complete the work.

END OF SECTION 32 01 26

[THIS PAGE BLANK]

**SECTION 32 05 16 – AGGREGATES FOR EXTERIOR IMPROVEMENTS**

**ITEM 32 05 16.7031 NO. 57 COARSE AGGREGATE**

**ITEM 32 05 16.7032 NO. 8 COARSE AGGREGATE**

**PART I: DESCRIPTION**

- A. 7031 – No. 57 Coarse Aggregate.
- B. 7032 – No. 8 Coarse Aggregate.

**PART II: GENERAL**

- A. When ordered by Director, furnish and install coarse aggregate, in accordance with Director's instructions as determined in the field and the applicable Sections of City of Pittsburgh Specifications. The extent and locations of the coarse aggregate is to conform to the orders of the Director given in the field.
- B. Aggregates as specified in PADOT Publication 408, Section 703 – Aggregate. Conform PADOT specifications to applicable sections of City of Pittsburgh Specifications.

**PART III: PRODUCTS AND MATERIALS**

- A. Provide products and materials specified in PADOT 408, Section 703.2 Coarse Aggregate, or approved type.

**PART IV: CONSTRUCTION AND EXECUTION [NOT USED]**

**PART V: MEASUREMENT AND PAYMENT**

- A. **NO. 57 COARSE AGGREGATE. Cubic Yard.**  
**NO. 8 COARSE AGGREGATE. Cubic Yard.**
  - 1. Payment will be made at the Unit Price Bid per cubic yard of coarse aggregate material furnished and installed.
  - 2. Payment is full compensation for the work described for the item, including all necessary labor, tools, machinery, and materials required to complete the work.

END OF SECTION 32 05 16

[THIS PAGE BLANK]



**SECTION 32 11 23 – AGGREGATE BASE COURSES**

- ITEM 32 11 23-0104 SUBBASE FOR PAVEMENT, NO. 2A, 4" DEPTH**
- ITEM 32 11 23-0106 SUBBASE FOR PAVEMENT, NO. 2A, 6" DEPTH**
- ITEM 32 11 23-0108 SUBBASE FOR PAVEMENT, NO. 2A, 8" DEPTH**
- ITEM 32 11 23-0110 SUBBASE FOR PAVEMENT, NO. 2A, 10" DEPTH**
- ITEM 32 11 23-0120 SUBBASE FOR PAVEMENT BY VOLUME, NO. 2A**
- ITEM 32 11 23-0121 SUBBASE FOR PAVEMENT BY WEIGHT, NO. 2A**

**PART I: DESCRIPTION**

- A. 0104 – Subbase for Pavement, No. 2A, 4" Depth.
- B. 0106 – Subbase for Pavement, No. 2A, 6" Depth.
- C. 0108 – Subbase for Pavement, No. 2A, 8" Depth.
- D. 0110 – Subbase for Pavement, No. 2A, 10" Depth.
- E. 0120 – Subbase for pavement by volume, No. 2A.
- F. 0121 – Subbase for pavement by weight, No. 2A.

**PART II: GENERAL**

- A. When ordered by Director, furnish and install subbase for pavement, in accordance with Director's instructions as determined in the field and the applicable Sections of City of Pittsburgh Specifications. The extent of the curb ramp is to conform to the orders of the Director given in the field.
- B. Subbase as specified in PADOT Publication 408, Section 350 – Subbase. Conform PADOT specifications to applicable sections of City of Pittsburgh Specifications.

**PART III: PRODUCTS AND MATERIALS**

- A. Provide products and materials specified in PADOT 408, Section 350.2 Material or approved type.

**PART IV: CONSTRUCTION AND EXECUTION**

- A. Execute work as specified in PADOT 408, Section 350.3 Construction.

**PART V: MEASUREMENT AND PAYMENT**

- A. SUBBASE FOR PAVEMENT, NO. 2A, 4" DEPTH. Square Yard.**
  - 1. Payment will be made at the Unit Price Bid per square yard furnished and installed.
  - 2. Payment is full compensation for the work described for the item, including all necessary labor, tools, machinery, and materials required to complete the work.
- B. SUBBASE FOR PAVEMENT, NO. 2A, 6" DEPTH. Square Yard.**
  - 1. Payment will be made at the Unit Price Bid per square yard furnished and installed.
  - 2. Payment is full compensation for the work described for the item, including all necessary labor, tools, machinery, and materials required to complete the work.
- C. SUBBASE FOR PAVEMENT, NO. 2A, 8" DEPTH. Square Yard.**
  - 1. Payment will be made at the Unit Price Bid per square yard furnished and installed.
  - 2. Payment is full compensation for the work described for the item, including all necessary labor, tools, machinery, and materials required to complete the work.

**D. SUBBASE FOR PAVEMENT, NO. 2A, 10" DEPTH. Square Yard.**

1. Payment will be made at the Unit Price Bid per square yard furnished and installed.
2. Payment is full compensation for the work described for the item, including all necessary labor, tools, machinery, and materials required to complete the work.

**E. SUBBASE FOR PAVEMENT BY VOLUME, NO. 2A. Cubic Yard.**

1. Payment will be made at the Unit Price Bid per cubic yard subbase material furnished and installed.
2. Payment is full compensation for the work described for the item, including all necessary labor, tools, machinery, and materials required to complete the work.

**F. SUBBASE FOR PAVEMENTBY WEIGHT, NO. 2A. Ton.**

1. Payment will be made at the Unit Price Bid per ton of subbase material furnished and installed.
2. Payment is full compensation for the work described for the item, including all necessary labor, tools, machinery, and materials required to complete the work.

END OF SECTION 32 11 23

**SECTION 32 12 19 – ASPHALT PAVING WEARING COURSES**

**ITEM 32 12 19-0384 1.5" WEARING COURSE, BITUMINOUS PAVEMENT**

**ITEM 32 12 19-6380 3.5" BINDER COURSE, BITUMINOUS PAVEMENT**

**PART I: DESCRIPTION**

- A. 0384 – Superpave Asphalt Mixture Design, HMA Wearing Course, PG 64-22, <0.3 Million ESALS, 9.5 MM Mix, 1 1/2" Depth, SRL-M, on a prepared surface.
- B. 6380 – Superpave Asphalt Mixture Design, HMA Binder Course, PG 64-22, <0.3 Million ESALS, 19 MM Mix, 3 1/2" Depth on a prepared surface.

**PART II: GENERAL**

- A. When ordered by Director, furnish and install bituminous pavement, in accordance with Director's instructions as determined in the field and the applicable Sections of City of Pittsburgh Specifications.
- B. The extent of the pavement is to conform to the orders of the Director given in the field.
- C. Bituminous pavement in PADOT Publication 408, Section 409 – Superpave Mixture Design, Standard and RPS Construction of Plant Mixed HMA Courses. Conform PADOT specifications to applicable sections of City of Pittsburgh Specifications.

**PART III: PRODUCTS AND MATERIALS**

- A. Provide products and materials specified in PADOT 408, Section 694.2 Material or approved type.

**PART IV: CONSTRUCTION AND EXECUTION**

- A. Execute work as specified in PADOT 408, Section 694.3 Construction.

**PART V: MEASUREMENT AND PAYMENT**

- A. **1.5" WEARING COURSE, BITUMINOUS PAVEMENT. Square Yard.**
  - 1. Payment will be made at the Unit Price Bid per ton of bituminous material furnished and installed.
  - 2. Payment is full compensation for the work described for the item, including all necessary labor, tools, machinery, and materials required to complete the work.
- B. **3.5" BINDER COURSE, BITUMINOUS PAVEMENT. Square Yard.**
  - 1. Payment will be made at the Unit Price Bid per ton of bituminous material furnished and installed.
  - 2. Payment is full compensation for the work described for the item, including all necessary labor, tools, machinery, and materials required to complete the work.

END OF SECTION 32 12 19

[THIS PAGE BLANK]

## SECTION 32 13 13 – CONCRETE PAVING

### ITEM 32 13 13.0200 8" REINFORCED CEMENT CONCRETE PAVEMENT

### ITEM 32 13 13.0202 10" REINFORCED CEMENT CONCRETE PAVEMENT

#### PART I: DESCRIPTION

- A. 0200 – Reinforced Concrete Pavement, Class P or PP Concrete, 8" Depth on a prepared base.
- B. 0202 – Reinforced Concrete Pavement, Class P or PP Concrete, 10" Depth on a prepared base.

#### PART II: GENERAL

- A. When ordered by Director, furnish and install reinforced cement concrete pavement, in accordance with Director's instructions as determined in the field and the applicable Sections of City of Pittsburgh Specifications.
- B. Reinforced concrete pavement per City of Pittsburgh Specification Section 1228 and other applicable sections of City of Pittsburgh Specifications.

#### PART III: PRODUCTS AND MATERIALS

- A. Concrete: 8" or 10" Cement Concrete Pavement meeting City of Pittsburgh, Class P or PP.
- B. Reinforcement: 6" x 6" – w2.9 x w2.9 WWF Deformed welded wire fabric meeting AASHTO M 221 (ASTM A 497).
- C. Expansion Joint Material: ½" Premolded Expansion Joint Filler: Fibrous or approved type.
  - 1. Provide expansion joint material meeting the requirement of PADOT 408 Section 705.1(c) from a manufacture listed in PADOT Bulleting 15 or approved equal.
- D. Joint Sealing Material: Silicone Joint Sealing Material or approved type.
  - 1. Provide joint sealing material meeting the requirement of PADOT 408 Section 705.4(a) from a manufacture listed in PADOT Bulleting 15 or approved equal.

#### PART IV: CONSTRUCTION AND EXECUTION

- A. Excavation as directed: Excavate as required or directed to total concrete pavement depth parallel with the finished surface of the pavement. Payment will be made under Excavation.
- B. Subgrade Preparation as directed: Thoroughly compact the subgrade, finish to a firm, even surface; moisten to nonmovement of material under compaction equipment. If directed, remove unsuitable material in the area to a depth that, when replaced and recompacted, the subgrade will meet nonmovement under compaction equipment. Payment will be made under Subbase Preparation.
- C. Place Aggregate for bed as directed: Spread aggregate on prepared subgrade, compact bed to 4" inch depth. Payment will be made under No. 2A Subbase, 4" Depth.
- D. Reinforced Concrete Pavement: Furnish and install 8-inch or 10-inch concrete pavement with steel reinforcement, in accordance with instructions issued in the field.
  - 1. Finish Surface: Broom finish, or as directed in the field.

**PART V: MEASUREMENT AND PAYMENT**

**A. 8" REINFORCED CEMENT CONCRETE PAVEMENT. Square Yard.**

1. Payment will be made at the Unit Price per square yard for reinforced cement concrete pavement furnished and installed.
2. Payment is full compensation for the work described for the item, including all necessary labor, tools, machinery, and materials required to complete the work.
3. Cost for demolition, excavation, base material and material removal is not included under this Item.

**B. 10" REINFORCED CEMENT CONCRETE PAVEMENT. Square Yard.**

1. Payment will be made at the Unit Price per square yard for reinforced cement concrete pavement furnished and installed.
2. Payment is full compensation for the work described for the item, including all necessary labor, tools, machinery, and materials required to complete the work.
3. Cost for demolition, excavation, base material and material removal is not included under this Item.

END OF SECTION 32 13 13

## SECTION 32 14 16 – BRICK UNIT PAVING

### ITEM 32 14 16.4130 UNIT PAVERS, BRICK SIDEWALK

#### PART I: DESCRIPTION

- A. 4130 – Brick surfacing with butt tight joints on  $\frac{3}{4}$ " latex mortar setting bed with four inch (4") thick concrete pavement, Class P or PP concrete on a prepared base.

#### PART II: GENERAL

- A. When ordered by Director, furnish and install sidewalk pavement, in accordance with Director's instructions as determined in the field and the applicable Sections of City of Pittsburgh Specifications. The extent of the sidewalk surfacing is to conform to the orders of the Director given in the field.
  - 1. New sidewalk pavement, that replaces existing sidewalk pavement, shall duplicate the paving type and pattern including all required scoring, expansion and construction joints, unless directed otherwise.
  - 2. Conform sidewalk pavement dimensions to a size which will correspond to those which exist in the immediate area.
- B. Perform all layout work as required or as directed. Provide notification to the Director to allow inspection and approval of layout prior to paving.
- C. Contractor shall utilize all existing base material and subgrade where appropriate:
  - 1. If upon removal of the existing pavement, additional base material is required to bring the base to the proper elevation, furnish and install No. 2A aggregate, payment per No. 2A Subbase.
  - 2. If upon removal of the existing concrete pavement, and base material, subbase does not meet compaction nonmovement of material under compaction equipment, excavate material in the area to a depth that, when replaced and recompacted, the subgrade will meet nonmovement under compaction equipment. Payment will be made under Subbase Preparation and Excavation.

#### PART III: PRODUCTS AND MATERIALS

- A. Concrete: 4" Cement Concrete Pavement meeting City of Pittsburgh, Class P or PP
- B. Brick Paving Unit: Per City of Pittsburgh Specification.
- C. Brick Setting Bed:  $\frac{3}{4}$ " latex mortar setting bed per City of Pittsburgh Specification.
- D. Expansion Joint Material:  $\frac{1}{2}$ " Premolded Expansion Joint Filler: Fibrous or approved type.
  - 1. Provide expansion joint material meeting the requirement of PADOT 408 Section 705.1(c) from a manufacture listed in PADOT Bulleting 15 or approved equal.
- E. Joint Sealing Material: Silicone Joint Sealing Material or approved type.
  - 1. Provide joint sealing material meeting the requirement of PADOT 408 Section 705.4(a) from a manufacture listed in PADOT Bulleting 15 or approved equal.

#### PART IV: CONSTRUCTION AND EXECUTION

- A. Excavation as directed: Excavate as required or directed to total sidewalk depth parallel with the finished surface of the sidewalk. Payment will be made under Excavation.

Housing Authority of the City of Pittsburgh  
Authority-wide Site Improvements

- B. Subgrade Preparation as directed: Thoroughly compact the subgrade, finish to a firm, even surface; moisten to nonmovement of material under compaction equipment. If directed, remove unsuitable material in the area to a depth that, when replaced and recompacted, the subgrade will meet nonmovement under compaction equipment. Payment will be made under Subbase Preparation.
- C. Place Aggregate for bed as directed: Spread aggregate on prepared subgrade, compact bed to 4" inch depth. Payment will be made under No. 2A Subbase, 4" Depth.
- D. Furnish and install four (4) inch thick concrete pavement, in accordance with instructions issued in the field. Payment incidental to sidewalk.
- E. Furnish and install brick pavers on  $\frac{3}{4}$ " latex mortar setting bed. Place paver to butt edges and ends to match existing pattern or as directed.
- F. Expansion Joints: Place 1/2 inch premolded expansion joint material at expansion joints in adjacent curb, between the sidewalk and curb, and between the sidewalk and rigid structures. Payment incidental to sidewalk.
- G. Seal Joints: Clean joints of all scale, dirt, curing compound, and other foreign material with a mechanized wire brush. All expansion joints shall be sealed with the specified sealant. Payment incidental to sidewalk.
- H. Backfilling: After curing, debris shall be removed and the areas adjoining shall be backfilled, graded and compacted to conform to the surrounding area in accordance with the lines and grades indicated. Payment incidental to sidewalk.

**PART V: MEASUREMENT AND PAYMENT**

**A. UNIT PAVERS, BRICK SIDEWALK. Square Yard.**

1. Payment will be made at the Unit Price Bid per square yard for the quantity brick surfacing with butt tight joints on a mortar setting bed with four (4) inch concrete pavement furnished and installed.
2. Payment is full compensation for the work described for the item, including all necessary labor, tools, machinery, and materials required to complete the work.
3. Cost for demolition, excavation, base material and material removal is not included under this Item.

END OF SECTION 32 14 16



## SECTION 32 14 40 – STONE PAVING

### ITEM 32 14 40.4140 UNIT PAVERS, BLOCK STONE SIDEWALK

#### PART I: DESCRIPTION

- A. 4140 – Block stone surfacing using Type 1 paving blocks with H.E.S. cement grouted joints on 1” cement and sand setting bed on a prepared base.

#### PART II: GENERAL

- A. When ordered by Director, furnish and install sidewalk pavement, in accordance with Director’s instructions as determined in the field and the applicable Sections of City of Pittsburgh Specifications. The extent of the sidewalk surfacing is to conform to the orders of the Director given in the field.
- B. Perform all layout work as required or as directed. Provide notification to the Director to allow inspection and approval of layout prior to paving.
- C. Contractor shall utilize all existing base material and subgrade where appropriate:
  - 1. If upon removal of the existing pavement, additional base material is required to bring the base to the proper elevation, furnish and install No. 2A aggregate, payment per No. 2A Subbase.
  - 2. If upon removal of the existing concrete pavement, and base material, subbase does not meet compaction nonmovement of material under compaction equipment, excavate material in the area to a depth that, when replaced and recompacted, the subgrade will meet nonmovement under compaction equipment. Payment will be made under Subbase Preparation and Excavation.

#### PART III: PRODUCTS AND MATERIALS

- A. High Early Strength (HES) concrete meeting City of Pittsburgh, Class PP
- B. Stone Paving Unit per City of Pittsburgh Specification.
- C. Expansion Joint Material: ½” Premolded Expansion Joint Filler: Fibrous or approved type.
  - 1. Provide expansion joint material meeting the requirement of PADOT 408 Section 705.1(c) from a manufacture listed in PADOT Bulleting 15 or approved equal.
- D. Joint Sealing Material: Silicone Joint Sealing Material or approved type.
  - 1. Provide joint sealing material meeting the requirement of PADOT 408 Section 705.4(a) from a manufacture listed in PADOT Bulleting 15 or approved equal.

#### PART IV: CONSTRUCTION AND EXECUTION

- A. Excavation as directed: Excavate as required or directed to total sidewalk depth parallel with the finished surface of the sidewalk. Payment will be made under Excavation.
- B. Subgrade Preparation as directed: Thoroughly compact the subgrade, finish to a firm, even surface; moisten to nonmovement of material under compaction equipment. If directed, remove unsuitable material in the area to a depth that, when replaced and recompacted, the subgrade will meet nonmovement under compaction equipment. Payment will be made under Subbase Preparation.
- C. Place Aggregate for bed as directed: Spread aggregate on prepared subgrade, compact bed to 4" inch depth. Payment will be made under No. 2A Subbase, 4” Depth.

Housing Authority of the City of Pittsburgh  
Authority-wide Site Improvements

- D. Place sand and cement mixture as directed on a compacted No. 2A subbase material in accordance with instructions issued in the field. Payment is incidental to the sidewalk.
- E. Expansion Joints: Place 1/2 inch premolded expansion joint material at expansion joints in adjacent curb, between the sidewalk and curb, and between the sidewalk and rigid structures. Payment incidental to sidewalk.
- F. Seal Joints: Clean joints of all scale, dirt, curing compound, and other foreign material with a mechanized wire brush. All expansion joints shall be sealed with the specified sealant. Payment incidental to sidewalk.
- G. Backfilling: After placement, debris shall be removed and the areas adjoining shall be backfilled, graded and compacted to conform to the surrounding area in accordance with the lines and grades indicated. Payment incidental to sidewalk.

**PART V: MEASUREMENT AND PAYMENT**

**A. UNIT PAVERS, BLOCK STONE SIDEWALK. Square Yard.**

- 1. Payment will be made at the Unit Price Bid per square yard for the block stone surfacing with grouted joint on a cement sand setting bed furnished and installed.
- 2. Payment is full compensation for the work described for the item, including all necessary labor, tools, machinery, and materials required to complete the work.
- 3. Cost for demolition, excavation, and material removal is not included under this Item.

END OF SECTION 32 14 40

## SECTION 32 16 13 – CURBS AND GUTTERS

### ITEM 32 16 13.4210 CONCRETE CURB, TANGENT

### ITEM 32 16 13.4220 CONCRETE CURB, RADIUS

### ITEM 32 16 13.4230 DEPRESSED CONCRETE CURB, TANGENT

### ITEM 32 16 13.4235 DEPRESSED CONCRETE CURB, RADIUS

#### PART I: DESCRIPTION

- A. 4210, 4220 – Concrete Curb, Class P or PP concrete, with battered face and seven inch reveal, reinforced with coated half inch (1/2") bars on the top and face of curb.
- B. 4230, 4235 – Depressed Concrete Curb, Class P or PP concrete, with battered top and 2 inch (2") to zero inch (0") reveal, reinforced with coated half inch (1/2") bars at the top of curb.

#### PART II: GENERAL

- A. When ordered by Director, furnish and install curb, in accordance with Director's instructions as determined in the field and the applicable Sections of City of Pittsburgh Specifications. The extent of the curb is to conform to the orders of the Director given in the field.

#### PART III: PRODUCTS AND MATERIALS

- A. Concrete: Cement Concrete Pavement meeting City of Pittsburgh, Class P or PP
- B. Reinforcement: Plain meeting AASHTO M 42 (ASTM A 616A), grades 350 or 400 (Grades 50 or 60).
- C. Expansion Joint Material: ½" Premolded Expansion Joint Filler: Fibrous or approved type.
  1. Provide expansion joint material meeting the requirement of PADOT 408 Section 705.1(c) from a manufacture listed in PADOT Bulleting 15 or approved equal.
- D. Joint Sealing Material: Silicone Joint Sealing Material or approved type.
  1. Provide joint sealing material meeting the requirement of PADOT 408 Section 705.4(a) from a manufacture listed in PADOT Bulleting 15 or approved equal.

#### PART IV: CONSTRUCTION AND EXECUTION

- A. Execute work as specified in PADOT 408, Section 630.3 Construction.

#### PART V: MEASUREMENT AND PAYMENT

##### A. CONCRETE CURB, TANGENT. Linear Foot.

1. Payment will be made at the Unit Price Bid per linear foot of tangent concrete curb with reinforcement furnished and installed.
2. Payment is full compensation for the work described for the item, including all necessary labor, tools, machinery, and materials required to complete the work.
3. Cost for demolition, excavation, and material removal is not included under this Item.

##### B. CONCRETE CURB, RADIUS. Linear Foot.

1. Payment will be made at the Unit Price Bid per linear foot of radial concrete curb with reinforcement furnished and installed.
2. Payment is full compensation for the work described for the item, including all necessary labor, tools, machinery, and materials required to complete the work.
3. Cost for demolition, excavation, and material removal is not included under this Item.

**C. DEPRESSED CONCRETE CURB, TANGENT. Linear Foot.**

1. Payment will be made at the Unit Price Bid per linear foot of tangent depressed concrete curb with reinforcement furnished and installed.
2. Payment is full compensation for the work described for the item, including all necessary labor, tools, machinery, and materials required to complete the work.
3. Cost for demolition, excavation, and material removal is not included under this Item.

**D. DEPRESSED CONCRETE CURB, RADIUS. Linear Foot.**

1. Payment will be made at the Unit Price Bid per linear foot of radial depressed concrete curb with reinforcement furnished and installed.
2. Payment is full compensation for the work described for the item, including all necessary labor, tools, machinery, and materials required to complete the work.
3. Cost for demolition, excavation, base material and material removal is not included under this Item.
  - a. Excavation as directed: Payment will be made under Excavation.
  - b. Subgrade Preparation as directed: Payment will be made under Subbase Preparation.
  - c. Aggregate subbase as directed: Payment will be made under No. 2A Subbase, 8" Depth.

**ITEM 32 16 13.5001 BITUMINOUS CONCRETE CURB**

**PART I: DESCRIPTION**

- A. 5001 – Twelve inch (12”) bituminous concrete wedge curb with six inch (6”) reveal at a 2:1 slope on a completed bituminous surface.

**PART II: GENERAL**

- A. When ordered by Director, furnish and install curb, in accordance with Director’s instructions as determined in the field and the applicable Sections of City of Pittsburgh Specifications. The extent of the curb is to conform to the orders of the Director given in the field.
- B. Bituminous concrete curb as specified in PADOT Publication 408, Section 636 – Bituminous Concrete Curb. Conform PADOT specifications to applicable sections of City of Pittsburgh Specifications.

**PART III: PRODUCTS AND MATERIALS**

- A. Provide products and materials specified in PADOT 408, Section 636.2 Material.

**PART IV: CONSTRUCTION AND EXECUTION**

- A. Execute work as specified in PADOT 408, Section 636.3 Construction.

**PART V: MEASUREMENT AND PAYMENT**

- A. **BITUMINOUS CONCRETE CURB. Linear foot.**
  - 1. Payment will be made at the Unit Price Bid per linear foot for the bituminous concrete curb furnished and installed.
  - 2. Payment is full compensation for the work described for the item, including all necessary labor, tools, machinery, and materials required to complete the work.

**ITEM 32 16 13.6005 CONCRETE GUTTER**

**PART I: DESCRIPTION**

- A. 6005 – Six inch (6”) cement concrete gutter, Class P or PP concrete, three feet (3’) wide with a nine inch (9”) concave depth on a prepared surface.

**PART II: GENERAL**

- A. When ordered by Director, furnish and install gutter, in accordance with Director’s instructions as determined in the field and the applicable Sections of City of Pittsburgh Specifications. The extent of the gutter is to conform to the orders of the Director given in the field.
- B. Concrete Gutter as specified in PADOT Publication 408, Section 640 – Plain Cement Concrete Gutter and as shown on Standard Drawing RC 64M – Curbs and Gutters. Conform PADOT specifications to applicable sections of City of Pittsburgh Specifications.

**PART III: PRODUCTS AND MATERIALS**

- A. Provide products and materials specified in PADOT 408, Section 640.2 Material.
- B. Concrete: 6” Cement Concrete Pavement meeting City of Pittsburgh, Class P or PP.

**PART IV: CONSTRUCTION AND EXECUTION**

- A. Execute work as specified in PADOT 408, Section 640.3 Construction.

**PART V: MEASUREMENT AND PAYMENT**

**A. CONCRETE GUTTER. Square Yard.**

1. Payment will be made at the Unit Price Bid per square yard for the concrete gutter furnished and installed.
2. Payment is full compensation for the work described for the item, including all necessary labor, tools, machinery, and materials required to complete the work.
3. Cost for excavation, subbase preparation and material removal is not included under this Item.

**ITEM 32 16 13.7350 CONCRETE CURB AND GUTTER**

**PART I: DESCRIPTION**

- A. 7350 – Concrete Curb and Gutter, Class P or PP concrete, with battered face and seven inch curb reveal and integral eighteen inch (18”) gutter, reinforced with coated half inch (1/2”) bars in curb and gutter.

**PART II: GENERAL**

- A. When ordered by Director, furnish and install curb and gutter, in accordance with Director’s instructions as determined in the field and the applicable Sections of City of Pittsburgh Specifications. The extent of the curb and gutter is to conform to the orders of the Director given in the field.

**PART III: PRODUCTS AND MATERIALS**

- A. Expansion Joint Material: ½” Premolded Expansion Joint Filler: Fibrous or approved type.
  - 1. Provide expansion joint material meeting the requirement of PADOT 408 Section 705.1(c) from a manufacture listed in PADOT Bulleting 15 or approved equal.
- B. Joint Sealing Material: Silicone Joint Sealing Material or approved type.
  - 1. Provide joint sealing material meeting the requirement of PADOT 408 Section 705.4(a) from a manufacture listed in PADOT Bulleting 15 or approved equal.

**PART IV: CONSTRUCTION AND EXECUTION**

- A. Execute work as specified in PADOT 408, Section 640.3 Construction.

**PART V: MEASUREMENT AND PAYMENT**

**A. CONCRETE CURB AND GUTTER. Linear Foot.**

- 1. Payment will be made at the Unit Price Bid per linear foot of concrete curb and gutter furnished and installed.
- 2. Payment is full compensation for the work described for the item, including all necessary labor, tools, machinery, and materials required to complete the work.
- 3. Cost for demolition, excavation, base material and material removal is not included under this Item.
  - a. Excavation as directed: Payment will be made under Excavation.
  - b. Subgrade Preparation as directed: Payment will be made under Subbase Preparation.
  - c. Aggregate subbase as directed: Payment will be made under No. 2A Subbase, 8” Depth.

END OF SECTION 32 16 13

[THIS PAGE BLANK]



## SECTION 32 16 23 – SIDEWALKS

**ITEM 32 16 23.4110 PLAIN CEMENT CONCRETE SIDEWALK**

**ITEM 32 16 23.4111 EXPOSED AGGREGATE PLAIN CEMENT CONCRETE SIDEWALK**

**ITEM 32 16 23.4120 REINFORCED CEMENT CONCRETE SIDEWALK**

**ITEM 32 16 23.4121 EXPOSED AGGREGATE REINFORCED CEMENT CONCRETE  
SIDEWALK**

### **PART I: DESCRIPTION**

- A. 4110 - Four inch (4") thick concrete pavement, Class P or PP concrete with broom finish on a prepared base.
- B. 4111 - Four inch (4") thick concrete pavement, Class P or PP concrete with exposed aggregate finish on a prepared base.
- C. 4120 - Four inch (4") thick concrete pavement, Class P or PP concrete, reinforcement of 6"x6" –w1.4 x w1.4 WWF, with broom finish on a prepared base.
- D. 4121 - Four inch (4") thick concrete pavement, Class P or PP concrete, reinforcement of 6"x6" –w1.4 x w1.4 WWF, with exposed aggregate finish on a prepared base.

### **PART II: GENERAL**

- A. When ordered by Director, furnish and install sidewalk pavement, in accordance with Director's instructions as determined in the field and the applicable Sections of City of Pittsburgh Specifications. The extent of the sidewalk surfacing is to conform to the orders of the Director given in the field.
  - 1. New sidewalk pavement, that replaces existing sidewalk pavement, shall duplicate the paving type and pattern including all required scoring, expansion and construction joints, unless directed otherwise.
  - 2. Conform sidewalk pavement dimensions to a size which will correspond to those which exist in the immediate area.
- B. Perform all layout work as required or as directed. Provide notification to the Director to allow inspection and approval of layout prior to paving.
- C. Contractor shall utilize all existing base material and subgrade where appropriate:
  - 1. If upon removal of the existing pavement, additional base material is required to bring the base to the proper elevation, furnish and install No. 2A aggregate, payment per No. 2A Subbase.
  - 2. If upon removal of the existing concrete pavement, and base material, subbase does not meet compaction nonmovement of material under compaction equipment, excavate material in the area to a depth that, when replaced and recompacted, the subgrade will meet nonmovement under compaction equipment. Payment will be made under Subbase Preparation Excavation.

### **PART III: PRODUCTS AND MATERIALS**

- A. Concrete: 4" Cement Concrete Pavement meeting City of Pittsburgh, Class P or PP
- B. Reinforcement: 6" x 6" – w2.9 x w2.9 WWF Deformed welded wire fabric meeting AASHTO M 221 (ASTM A 497).
- C. Expansion Joint Material: ½" Premolded Expansion Joint Filler: Fiberous or approved type.

1. Provide expansion joint material meeting the requirement of PADOT 408 Section 705.1(c) from a manufacture listed in PADOT Bulleting 15 or approved equal.
- D. Joint Sealing Material: Silicone Joint Sealing Material or approved type.
  1. Provide joint sealing material meeting the requirement of PADOT 408 Section 705.4(a) from a manufacture listed in PADOT Bulleting 15 or approved equal.
- E. Exposed Aggregate: Pea Gravel washed natural mineral aggregate, 1/8 inch minimum and 1/4 inch maximum size, beige/brown color, from a single source.

**PART IV: CONSTRUCTION AND EXECUTION**

- A. Excavation as directed: Excavate as required or directed to total sidewalk depth parallel with the finished surface of the sidewalk. Payment will be made under Excavation.
- B. Subgrade Preparation as directed: Thoroughly compact the subgrade, finish to a firm, even surface; moisten to nonmovement of material under compaction equipment. If directed, remove unsuitable material in the area to a depth that, when replaced and recompacted, the subgrade will meet nonmovement under compaction equipment. Payment will be made under Subbase Preparation.
- C. Place Aggregate for bed as directed: Spread aggregate on prepared subgrade, compact bed to 4" inch depth. Payment will be made under No. 2A Subbase, 4" Depth.
- D. Plain/Reinforced Sidewalk: Furnish and install four (4) inch thick concrete pavement with or without steel reinforcement, in accordance with instructions issued in the field.
  1. Finish Surface: Broom finish, or as directed in the field.
- E. Plain/Reinforced Exposed Aggregate Sidewalk: Furnish and install four (4) inch thick concrete pavement with pea gravel washed natural mineral aggregate, 1/8 inch minimum and 1/4 inch maximum size, beige/brown and grey in color, from a single source., in accordance with instructions issued in the field.
  1. 1. Finish Surface: Wash concrete surfaces to which surface retarder has been applied with clean water, and scrub with stiff bristle brush exposing aggregate.
- F. Expansion Joints: Place 1/2 inch premolded expansion joint material at expansion joints in adjacent curb, between the sidewalk and curb, and between the sidewalk and rigid structures. Payment incidental to sidewalk.
- G. Seal Joints: Clean joints of all scale, dirt, curing compound, and other foreign material with a mechanized wire brush. All expansion joints shall be sealed with the specified sealant. Payment incidental to sidewalk.
- H. Backfilling: After curing, debris shall be removed and the areas adjoining shall be backfilled, graded and compacted to conform to the surrounding area in accordance with the lines and grades indicated. Payment incidental to sidewalk.

**PART V: MEASUREMENT AND PAYMENT**

- A. **PLAIN CEMENT CONCRETE SIDEWALK . Square Yard.**
  1. Payment will be made at the Unit Price per square yard for the quantity of four (4) inch concrete pavement furnished and installed.
  2. Payment is full compensation for the work described for the item, including all necessary labor, tools, machinery, and materials required to complete the work.
  3. Cost for demolition, excavation, base material and material removal is not included under this Item.

**B. EXPOSED AGGREGATE PLAIN CEMENT CONCRETE SIDEWALK. Square Yard.**

1. Payment will be made at the Unit Price per square yard for the quantity of four (4) inch concrete pavement with exposed aggregate furnished and installed.
2. Payment is full compensation for the work described for the item, including all necessary labor, tools, machinery, and materials required to complete the work.
3. Cost for demolition, excavation, base material and material removal is not included under this Item.

**C. REINFORCED CEMENT CONCRETE SIDEWALK. Square Yard.**

1. Payment will be made at the Unit Price per square yard for the quantity of four (4) inch reinforced concrete pavement furnished and installed.
2. Payment is full compensation for the work described for the item, including all necessary labor, tools, machinery, and materials required to complete the work.
3. Cost for demolition, excavation, base material and material removal is not included under this Item.

**D. EXPOSED AGGREGATE REINFORCED CEMENT CONCRETE SIDEWALK. Square Yard.**

1. Payment will be made at the Unit Price per square yard for the quantity of four (4) inch reinforced concrete pavement with exposed aggregate furnished and installed.
2. Payment is full compensation for the work described for the item, including all necessary labor, tools, machinery, and materials required to complete the work.
3. Cost for demolition, excavation, base material and material removal is not included under this Item.

**ITEM 32 16 23.4600 ACCESSIBLE SIDEWALK RAMP, TANGENT**

**ITEM 32 16 23.4650 ACCESSIBLE SIDEWALK RAMP, RADIUS**

**PART I: DESCRIPTION**

- A. 4600 – Six inch (6”) thick concrete pavement, Class P or PP concrete, reinforcement of 6”x6” –w2.9 x w2.9 WWF, and detectable warning surface, with broom finish on a prepared base with clearances and slopes in compliance with Uniform Federal Accessibility Standards (UFAS) for residential facilities covered by HUD's standards and ADA and ABA Accessibility Guidelines.
- B. 4650 – Six inch (6”) thick concrete pavement, Class P or PP concrete, reinforcement of 6”x6” –w2.9 x w2.9 WWF, and detectable warning surface, with broom finish on a prepared base with clearances and slopes in compliance with Uniform Federal Accessibility Standards (UFAS) for residential facilities covered by HUD's standards and ADA and ABA Accessibility Guidelines.

**PART II: GENERAL**

- A. When ordered by Director, furnish and install accessible sidewalk ramp, in accordance with Director’s instructions as determined in the field and the applicable Sections of City of Pittsburgh Specifications. The extent of the accessible driveway apron is to conform to the orders of the Director given in the field.
- B. Perform all layout work as required or as directed. Provide notification to the Director to allow inspection and approval of layout prior to paving.
- C. Accessible sidewalk ramp to comply with the Americans with Disabilities Act and Architectural Barriers Act Accessibility Guidelines, latest addition and the Uniform Federal Accessibility Standards (UFAS) for residential facilities covered by HUD's, latest addition.
- D. Accessible sidewalk ramp as shown on Standard Drawing RC 67M – Curb Ramps and Sidewalks. Conform PADOT drawing to applicable sections of City of Pittsburgh drawings.

**PART III: PRODUCTS AND MATERIALS**

- A. Concrete: 6” Cement Concrete Pavement meeting City of Pittsburgh, Class P or PP.
- B. Reinforcement: 6” x 6” – w2.9 x w2.9 WWF Deformed welded wire fabric meeting AASHTO M 221 (ASTM A 497).
- C. Expansion Joint Material: ½” Premolded Expansion Joint Filler: Fibrous or approved type.
  - 1. Provide expansion joint material meeting the requirement of PADOT 408 Section 705.1(c) from a manufacture listed in PADOT Bulleting 15 or approved equal.
- D. Joint Sealing Material: Silicone Joint Sealing Material or approved type.
  - 1. Provide joint sealing material meeting the requirement of PADOT 408 Section 705.4(a) from a manufacture listed in PADOT Bulleting 15 or approved equal.

**PART IV: CONSTRUCTION AND EXECUTION [Not Used]**

- A. Excavation as directed: Excavate as required or directed to total sidewalk depth parallel with the finished surface of the sidewalk ramp. Payment will be made under Excavation.
- B. Subgrade Preparation as directed: Thoroughly compact the subgrade, finish to a firm, even surface; moisten to nonmovement of material under compaction equipment. If directed, remove unsuitable material in the area to a depth that, when replaced and

recompacted, the subgrade will meet nonmovement under compaction equipment.  
Payment will be made under Subbase Preparation.

- C. Place Aggregate for bed as directed: Spread aggregate on prepared subgrade, compact bed to 4" inch depth. Payment will be made under No. 2A Subbase, 4" Depth.
- D. Reinforced Sidewalk Ramp: Furnish and install four (4) inch thick concrete pavement with steel reinforcement, in accordance with instructions issued in the field.
  - 1. Finish Surface: Broom finish, or as directed in the field.
- E. Expansion Joints: Place 1/2 inch premolded expansion joint material at expansion joints in adjacent curb, between the sidewalk and curb, and between the sidewalk and rigid structures. Payment incidental to sidewalk.
- F. Seal Joints: Clean joints of all scale, dirt, curing compound, and other foreign material with a mechanized wire brush. All expansion joints shall be sealed with the specified sealant. Payment incidental to sidewalk.
- G. Backfilling: After curing, debris shall be removed and the areas adjoining shall be backfilled, graded and compacted to conform to the surrounding area in accordance with the lines and grades indicated. Payment incidental to sidewalk.

**PART V: MEASUREMENT AND PAYMENT**

**A. ACCESSIBLE SIDEWALK RAMP, TANGENT. Square Yard.**

- 1. Payment will be made at the Unit Price Bid per square yard for the accessible sidewalk ramp on tangent furnished and installed.
- 2. Payment is full compensation for the work described for the item, including all necessary labor, tools, machinery, and materials required to complete the work.
- 3. Cost for excavation, subbase preparation and material removal is not included under this Item.
  - a. Excavation as directed: Payment will be made under Excavation.
  - b. Subgrade Preparation as directed: Payment will be made under Subbase Preparation.
  - c. Aggregate subbase as directed: Payment will be made under No. 2A Subbase, 6" Depth.
  - d. Depressed Concrete Curb as directed: Payment will be made under Depressed Concrete Curb, Tangent.
  - e. Aggregate subbase for Curb as directed: Payment will be made under No. 2A Subbase, 8" Depth.

**B. ACCESSIBLE SIDEWALK RAMP, RADIUS. Square Yard.**

- 1. Payment will be made at the Unit Price Bid per square yard for the accessible sidewalk ramp on radius furnished and installed.
- 2. Payment is full compensation for the work described for the item, including all necessary labor, tools, machinery, and materials required to complete the work.
- 3. Cost for excavation, subbase preparation and material removal is not included under this Item.
  - a. Excavation as directed: Payment will be made under Excavation.
  - b. Subgrade Preparation as directed: Payment will be made under Subbase Preparation.

Housing Authority of the City of Pittsburgh  
Authority-wide Site Improvements

- c. Aggregate subbase as directed: Payment will be made under No. 2A Subbase, 6" Depth.
- d. Depressed Concrete Curb as directed: Payment will be made under Depressed Concrete Curb, Radius.
- e. Aggregate subbase for Curb as directed: Payment will be made under No. 2A Subbase, 8" Depth.

**ITEM 32 16 23.4700 BUILT-UP CURB RAMP**

**PART I: DESCRIPTION**

- A. 4700 – Bituminous built-up curb ramp and detectable warning surface on a completed bituminous surface with clearances and slopes in compliance with Uniform Federal Accessibility Standards (UFAS) for residential facilities covered by HUD's standards and ADA and ABA Accessibility Guidelines.

**PART II: GENERAL**

- A. When ordered by Director, furnish and install a built-up curb ramp, in accordance with Director's instructions as determined in the field and the applicable Sections of City of Pittsburgh Specifications.
- B. The extent and location of the curb ramp is to conform to the orders of the Director given in the field.
- C. Built-up curb ramp as specified in PADOT Publication 408, Section 694 – Built-up Curb Ramps and as shown on Standard Drawing RC 67M – Curb ramps and Sidewalks. Conform PADOT specifications to applicable sections of City of Pittsburgh Specifications.

**PART III: PRODUCTS AND MATERIALS**

- A. Provide products and materials specified in PADOT 408, Section 694.2 Material or approved type.

**PART IV: CONSTRUCTION AND EXECUTION**

- A. Execute work as specified in PADOT 408, Section 694.3 Construction.

**PART V: MEASUREMENT AND PAYMENT**

**A. BUILT-UP CURB RAMP. Ton.**

1. Payment will be made at the Unit Price Bid per ton of bituminous material for a built-up curb ramp furnished and installed.
2. Payment is full compensation for the described work , including all necessary labor, tools, machinery, and materials required to complete the work.

END OF SECTION 32 16 23

[THIS PAGE BLANK]



## SECTION 32 16 33 – DRIVEWAYS

### ITEM 32 16 33.4410 PLAIN CEMENT CONCRETE DRIVEWAY

### ITEM 32 16 33.4420 REINFORCED CEMENT CONCRETE DRIVEWAY

#### PART I: DESCRIPTION

- A. 4410 - Six inch (6") thick concrete pavement, Class P or PP concrete with broom finish on a prepared base.
- B. 4420 - Six inch (6") thick concrete pavement, Class P or PP concrete, reinforcement of 6"x6" –w2.9 x w2.9 WWF, with broom finish on a prepared base.

#### PART II: GENERAL

- A. When ordered by Director, furnish and install driveway pavement, in accordance with Director's instructions as determined in the field and the applicable Sections of City of Pittsburgh Specifications. The extent of the driveway surfacing is to conform to the orders of the Director given in the field.

#### PART III: PRODUCTS AND MATERIALS

- A. Concrete: 6" Cement Concrete Pavement meeting City of Pittsburgh, Class P or PP
- B. Reinforcement: 6" x 6" – w2.9 x w2.9 WWF Deformed welded wire fabric meeting AASHTO M 221 (ASTM A 497).
- C. Expansion Joint Material: ½" Premolded Expansion Joint Filler: Fibrous or approved type.
  - 1. Provide expansion joint material meeting the requirement of PADOT 408 Section 705.1(c) from a manufacture listed in PADOT Bulleting 15 or approved equal.
- D. Joint Sealing Material: Silicone Joint Sealing Material or approved type.
  - 1. Provide joint sealing material meeting the requirement of PADOT 408 Section 705.4(a) from a manufacture listed in PADOT Bulleting 15 or approved equal.

#### PART IV: CONSTRUCTION AND EXECUTION

- A. Plain/Reinforced Sidewalk: Furnish and install four (4) inch thick concrete pavement with or without steel reinforcement, in accordance with instructions issued in the field.
  - 1. Finish Surface: Broom finish, or as directed in the field.
- B. Expansion Joints: Place 1/2 inch premolded expansion joint material at expansion joints in adjacent curb, between the sidewalk and curb, and between the sidewalk and rigid structures. Payment incidental to sidewalk.
- C. Seal Joints: Clean joints of all scale, dirt, curing compound, and other foreign material with a mechanized wire brush. All expansion joints shall be sealed with the specified sealant. Payment incidental to sidewalk.
- D. Backfilling: After curing, debris shall be removed and the areas adjoining shall be backfilled, graded and compacted to conform to the surrounding area in accordance with the lines and grades indicated. Payment incidental to sidewalk.

#### PART V: MEASUREMENT AND PAYMENT

- A. **PLAIN CEMENT CONCRETE DRIVEWAY. Square Yard.**
  - 1. Payment will be made at the Unit Price per square yard for the quantity of six (6) inch concrete pavement furnished and installed.

Housing Authority of the City of Pittsburgh  
Authority-wide Site Improvements

2. Payment is full compensation for the work described for the item, including all necessary labor, tools, machinery, and materials required to complete the work.
3. Cost for demolition, excavation, base material and material removal is not included under this Item.
  - a. Excavation as directed: Payment will be made under Excavation.
  - b. Subgrade Preparation as directed: Payment will be made under Subbase Preparation.
  - c. Aggregate subbase as directed: Payment will be made under No. 2A Subbase, 6" Depth.
  - d. Subbase repair as directed: Payment will be made under No. 2A Subbase.

**B. REINFORCED CEMENT CONCRETE DRIVEWAY. Square Yard.**

1. Payment will be made at the Unit Price per square yard for the quantity of six (6) inch reinforced concrete pavement furnished and installed.
2. Payment is full compensation for the work described for the item, including all necessary labor, tools, machinery, and materials required to complete the work.
3. Cost for demolition, excavation, base material and material removal is not included under this Item.
  - a. Excavation as directed: Payment will be made under Excavation.
  - b. Subgrade Preparation as directed: Payment will be made under Item C31-2100 Subbase Preparation.
  - c. Aggregate subbase as directed: Payment will be made under No. 2A Subbase, 6" Depth.
  - d. Subbase repair as directed: Payment will be made under No. 2A Subbase.

**ITEM 32 16 33.4500 ACCESSIBLE DRIVEWAY APRON**

**PART I: DESCRIPTION**

- A. 4500 – Six inch (6”) thick concrete pavement, Class P or PP concrete, reinforcement of 6”x6” –w2.9 x w2.9 WWF, with broom finish on a prepared base with clearances and slopes in compliance with Uniform Federal Accessibility Standards (UFAS) for residential facilities covered by HUD's standards and ADA and ABA Accessibility Guidelines.

**PART II: GENERAL**

- A. When ordered by Director, furnish and install accessible driveway apron, in accordance with Director’s instructions as determined in the field and the applicable Sections of City of Pittsburgh Specifications. The extent of the accessible driveway apron is to conform to the orders of the Director given in the field.
- B. Perform all layout work as required or as directed. Provide notification to the Director to allow inspection and approval of layout prior to paving.
- C. Accessible driveway apron to comply with the Americans with Disabilities Act and Architectural Barriers Act Accessibility Guidelines, latest addition and the Uniform Federal Accessibility Standards (UFAS) for residential facilities covered by HUD's, latest addition.
- D. Accessible driveway apron as shown on Standard Drawing RC 67M – Curb Ramps and Sidewalks – Driveway Aprons. Conform PADOT drawing to applicable sections of City of Pittsburgh drawings.

**PART III: PRODUCTS AND MATERIALS**

- A. Concrete: 6” Cement Concrete Pavement meeting City of Pittsburgh, Class P or PP.
- B. Reinforcement: 6” x 6” – w2.9 x w2.9 WWF Deformed welded wire fabric meeting AASHTO M 221 (ASTM A 497).
- C. Expansion Joint Material: ½” Premolded Expansion Joint Filler: Fibrous or approved type.
  - 1. Provide expansion joint material meeting the requirement of PADOT 408 Section 705.1(c) from a manufacture listed in PADOT Bulleting 15 or approved equal.
- D. Joint Sealing Material: Silicone Joint Sealing Material or approved type.
  - 1. Provide joint sealing material meeting the requirement of PADOT 408 Section 705.4(a) from a manufacture listed in PADOT Bulleting 15 or approved equal.

**PART IV: CONSTRUCTION AND EXECUTION [Not Used]**

**PART V: MEASUREMENT AND PAYMENT**

- A. **ACCESSIBLE DRIVEWAY APRON. Square Yard.**
  - 1. Payment will be made at the Unit Price Bid per square yard for the accessible driveway apron furnished and installed.
  - 2. Payment is full compensation for the work described for the item, including all necessary labor, tools, machinery, and materials required to complete the work.
  - 3. Cost for excavation, subbase preparation and material removal is not included under this Item.
    - a. Excavation as directed: Payment will be made under Excavation.
    - b. Subgrade Preparation as directed: Payment will be made under Subbase Preparation.

Housing Authority of the City of Pittsburgh  
Authority-wide Site Improvements

- c. Aggregate subbase as directed: Payment will be made under No. 2A Subbase, 6" Depth.
- d. Depressed Concrete Curb as directed: Payment will be made under Depressed Concrete Curb, Tangent or Radius.
- e. Aggregate subbase for Curb as directed: Payment will be made under No. 2A Subbase, 8" Depth.

END OF SECTION 32 16 33

## SECTION 32 17 13 – PARKING BUMPERS

### ITEM 32 17 13.0019 PRECAST CONCRETE PARKING BUMPERS

#### PART I: DESCRIPTION

- A. 0019 – Precast concrete parking bumpers, 6' length, and anchorage.

#### PART II: GENERAL

- A. When ordered by Director, furnish and install precast concrete parking bumpers, in accordance with Director's instructions as determined in the field and the applicable Sections of City of Pittsburgh Specifications.
- B. The location of precast concrete parking bumpers is to conform to the orders of the Director given in the field.
- C. Submit product data for approval to Director.

#### PART III: PRODUCTS AND MATERIALS

##### A. Parking Bumpers

1. Provide precast concrete parking bumpers of half octagonal configuration and dimensions to be approved by Director.
2. Concrete: Class P or PP
3. Embed Reinforcing Steel: Each bumper shall be reinforced with two No. 4 deformed steel reinforcing bars, minimum or as approved.
4. Sleeve for two dowels to accommodate the installation of rebar. Holes shall be positioned 6 inches in from each end or as approved. Bumpers to be installed on concrete slabs of parking structures, shall be manufactured without holes.

##### B. Dowels

1. Cut reinforcing steel, ½ inch dia, 18" long.

#### PART IV: CONSTRUCTION AND EXECUTION

##### A. Installation

1. Install units without damage to shape or finish. Replace or repair damaged units.
2. Install units in alignment with adjacent work.
3. Fasten units in place with 2 dowels per unit.

#### PART V: MEASUREMENT AND PAYMENT

##### A. PRECAST CONCRETE PARKING BUMPERS. Each.

1. Payment will be made at the Unit Price Bid per each precast concrete parking bumpers furnished and installed.
2. Payment is full compensation for the work described for the item, including all necessary labor, tools, machinery, and materials required to complete the work.

END OF SECTION 32 17 13

[THIS PAGE BLANK]

**SECTION 32 17 23 – PAVEMENT MARKINGS**

**ITEM 32 17 23.1000 4" STANDARD PAVEMENT MARKINGS**

**ITEM 32 17 23.1001 6" STANDARD PAVEMENT MARKINGS**

**ITEM 32 17 23.1002 8" STANDARD PAVEMENT MARKINGS**

**ITEM 32 17 23.1003 12" STANDARD PAVEMENT MARKINGS**

**ITEM 32 17 23.1004 24" STANDARD PAVEMENT MARKINGS**

**ITEM 32 17 23.4000 PAVEMENT MARKINGS, CURB**

**PART I: DESCRIPTION**

- A. 1000 – Waterborne Pavement Markings, 4" Wide, Color: White, Yellow or Blue.
- B. 1001 – Waterborne Pavement Markings, 6" Wide, Color: White, Yellow or Blue.
- C. 1002 – Waterborne Pavement Markings, 8" Wide, Color: White, Yellow or Blue.
- D. 1003 – Waterborne Pavement Markings, 12" Wide, Color: White, Yellow or Blue.
- E. 1004 – Waterborne Pavement Markings, 24" Wide, Color: White, Yellow or Blue.
- F. 4000 – Pavement Markings for Curbs, Color: Yellow or Blue.

**PART II: GENERAL**

- A. When ordered by Director, furnish and application of waterborne pavement markings, in accordance with Director's instructions as determined in the field and the applicable Sections of City of Pittsburgh Specifications.
- B. The extent and locations of waterborne pavement marking is to conform to the orders of the Director given in the field.
- C. Waterborne pavement marking as specified in PADOT Publication 408, Section 962 – Waterborne Pavement Markings and as shown on Standard Drawing TC 8600M – Pavement Markings. Conform PADOT specifications to applicable sections of City of Pittsburgh Specifications.

**PART III: PRODUCTS AND MATERIALS**

- A. Provide products and materials specified in PADOT 408, Section 962.2 Material or approved type.

**PART IV: CONSTRUCTION AND EXECUTION**

- A. Execute work as specified in PADOT 408, Section 962.3 Construction.

**PART V: MEASUREMENT AND PAYMENT**

- A. **4" STANDARD PAVEMENT MARKINGS. Linear Foot.**
- 6" STANDARD PAVEMENT MARKINGS. Linear Foot.**
- 8" STANDARD PAVEMENT MARKINGS. Linear Foot.**
- 12" STANDARD PAVEMENT MARKINGS. Linear Foot.**
- 24" STANDARD PAVEMENT MARKINGS. Linear Foot.**
- PAVEMENT MARKINGS, CURB. Linear Foot.**

- 1. Payment will be made at the Unit Price Bid per linear foot of waterborne pavement markings furnished and applied.

Housing Authority of the City of Pittsburgh  
Authority-wide Site Improvements

2. Payment is full compensation for the work described for the item, including all necessary labor, tools, machinery, and materials required to complete the work.



**ITEM 32 17 23.9001 REMOVE PAVEMENT MARKINGS**

**PART I: DESCRIPTION**

- A. 0012 – Removal of pavement markings and legends.

**PART II: GENERAL**

- A. When ordered by Director, remove pavement markings and legends, in accordance with Director's instructions as determined in the field and the applicable Sections of City of Pittsburgh Specifications. The extent of removal is to conform to the orders of the Director given in the field.
- B. Remove Pavement markings as specified in PADOT Publication 408, Section 963 – Pavement Marking Removal. Conform PADOT specifications to applicable sections of City of Pittsburgh Specifications.

**PART III: PRODUCTS AND MATERIALS [NOT USED]**

**PART IV: CONSTRUCTION AND EXECUTION**

- A. Execute work as specified in PADOT 408, Section 963.3 Construction.

**PART V: MEASUREMENT AND PAYMENT**

**A. REMOVE PAVEMENT MARKINGS. Square Feet.**

1. Payment will be made at the Unit Price Bid per square feet of removed pavement markings.
2. Payment is full compensation for the work described for the item, including all necessary labor, tools, machinery, and materials required to complete the work.

END OF SECTION 32 17 23

[THIS PAGE BLANK]

## SECTION 32 17 26 – TACTILE WARNING SURFACING

### ITEM 32 17 26.4850 DETECTABLE WARNING SURFACE, ACCESSIBLE RAMP ALTERATION

### ITEM 32 17 26.4900 DETECTABLE WARNING SURFACE, PAVEMENT

#### PART I: DESCRIPTION

- A. 4850 – Detectable warning surface in an existing cement concrete accessible ramp in compliance with Uniform Federal Accessibility Standards (UFAS) for residential facilities covered by HUD's standards and ADA and ABA Accessibility Guidelines.
- B. 4900 – Detectable warning surface on a completed bituminous or concrete surface in compliance with Uniform Federal Accessibility Standards (UFAS) for residential facilities covered by HUD's standards and ADA and ABA Accessibility Guidelines.

#### PART II: GENERAL

- A. When ordered by Director, furnish and install a detectable warning surface, in accordance with Director's instructions as determined in the field and the applicable Sections of City of Pittsburgh Specifications.
- B. The placement of detectable warning surface is to conform to the orders of the Director given in the field.
- C. Detectable warning surface as specified in PADOT Publication 408, Section 695 – Detectable Warning Surface and as shown on Standard Drawing RC 67M – Curb ramps and Sidewalks. Conform PADOT specifications to applicable sections of City of Pittsburgh Specifications.

#### PART III: PRODUCTS AND MATERIALS

- A. Provide products and materials specified in PADOT 408, Section 695.2 Material or approved type.

#### PART IV: CONSTRUCTION AND EXECUTION

- A. Execute work as specified in PADOT 408, Section 695.3 Construction.

#### PART V: MEASUREMENT AND PAYMENT

##### A. DETECTABLE WARNING SURFACE, ACCESSIBLE RAMP ALTERATION.

###### Square Foot.

- 1. Payment will be made at the Unit Price Bid per square foot of detectable warning surface installed in an existing sidewalk curb ramp in order to provide a tactile warning for pedestrians with visual impairments furnished and installed.
- 2. Payment is full compensation for the work described for the item, including all necessary labor, tools, machinery, and materials required to complete the work.

##### B. DETECTABLE WARNING SURFACE, PAVEMENT, Square Foot.

- 1. Payment will be made at the Unit Price Bid per square foot of detectable warning surface in bituminous or concrete pavement in order to provide a tactile warning for pedestrians with visual impairments furnished and installed.
- 2. Payment is full compensation for the work described for the item, including all necessary labor, tools, machinery, and materials required to complete the work

Housing Authority of the City of Pittsburgh  
Authority-wide Site Improvements

END OF SECTION 32 17 26

## SECTION 32 31 13 – CHAIN LINK FENCES AND GATES

### ITEM 32 31 13.0001 CHAIN LINK FENCE

### ITEM 32 31 13.0722 CHAIN LINK FENCE VEHICULAR GATE

### ITEM 32 31 13.0611 CHAIN LINK FENCE PEDESTRIAN GATE

#### PART I: DESCRIPTION

- A. 0001 – PADOT right-of-way Fence, Type 1.
- B. 0722 – Vehicular gate for Type 1 right-of-way fence, 12 foot opening.
- C. 0611 – Pedestrian gate for Type 1 right-of-way fence, 5 foot opening.

#### PART II: GENERAL

- A. When ordered by Director, furnish and install chain link fence and access gates, in accordance with Director's instructions as determined in the field and the applicable Sections of City of Pittsburgh Specifications.
- B. The extent of the chain link fence and location of access gates is to conform to the orders of the Director given in the field.
- C. Chain link fence as specified in PADOT Publication 408, Section 624 – Right-Of-Way Fence and as shown on Standard Drawing RC 60M – Right-of-Way Fence. Conform PADOT specifications to applicable sections of City of Pittsburgh Specifications.

#### PART III: PRODUCTS AND MATERIALS

- A. Provide products and materials specified in PADOT 408, Section 624.2 Material or approved type.

#### PART IV: CONSTRUCTION AND EXECUTION

- A. Execute work as specified in PADOT 408, Section 624.3 Construction.

#### PART V: MEASUREMENT AND PAYMENT

##### A. CHAIN LINK FENCE. Linear Foot.

- 1. Payment will be made at the Unit Price Bid per linear foot of chain link fence furnished and installed.
- 2. Payment is full compensation for the work described for the item, including all necessary labor, tools, machinery, and materials required to complete the work.

##### B. CHAIN LINK FENCE VEHICULAR GATE. Each.

- 1. Payment will be made at the Unit Price Bid per each chain link fence vehicular gate furnished and installed.
- 2. Payment is full compensation for the work described for the item, including all necessary labor, tools, machinery, and materials required to complete the work.

##### C. CHAIN LINK FENCE PEDESTRIAN GATE. Each.

- 1. Payment will be made at the Unit Price Bid per each chain link fence pedestrian gate furnished and installed.
- 2. Payment is full compensation for the work described for the item, including all necessary labor, tools, machinery, and materials required to complete the work.

END OF SECTION 32 31 13

[THIS PAGE BLANK]

**SECTION 32 32 13 – CAST-IN-PLACE CONCRETE RETAINING WALL**

**ITEM 32 32 13.6000 RETAINING WALL, CAST IN PLACE, 8" THICK, CLASS P OR PP  
REINFORCED CONCRETE**

**PART I: DESCRIPTION**

- A. 6000 – Concrete retaining wall, 8" thick, Class P or PP Reinforced Concrete, cast in place, design and installation to lines and grades established by Director.

**PART II: GENERAL**

- A. When ordered by Director, furnish and install cast in place reinforced concrete retaining wall, in accordance with Director's instructions as determined in the field and the applicable Sections of City of Pittsburgh Specifications.
- B. Retaining wall per City of Pittsburgh Specification Section 554 and other applicable sections of City of Pittsburgh Specifications.

**PART III: PRODUCTS AND MATERIALS [NOT USED]**

**PART IV: CONSTRUCTION AND EXECUTION**

- A. Design for reinforced concrete retaining wall.
  - 1. The design analysis for the retaining wall shall be P.E.-sealed retaining wall plans prepared by the Wall Design Engineer and shall consider the external stability against sliding and overturning, internal stability in accordance with acceptable engineering practice and these specifications. The internal and external stability analysis shall be performed using the recommended minimum factors of safety.
  - 2. Geotechnical Engineer shall perform bearing capacity, settlement estimates, and global stability analysis based on the final wall design provided by the Wall Design Engineer and coordinate any required changes with Wall Design Engineer.

**PART V: MEASUREMENT AND PAYMENT**

**A. RETAINING WALL, CAST IN PLACE, 8" THICK, CLASS P OR PP  
REINFORCED CONCRETE. Cubic Yard.**

- 1. Payment will be made at the Unit Price Bid per cubic yard for a reinforced concrete retaining wall furnished and installed.
- 2. Payment is full compensation for the work described for the item, including all necessary labor, tools, machinery, and materials required to complete the work.
- 3. Excavation and material removal and disposal is not included under this Item.
  - a. Excavation for Cast in Place Retaining wall: Payment will be made under Trench Excavation.

END OF SECTION 32 32 13

[THIS PAGE BLANK]



## SECTION 32 32 23 – SEGMENTAL RETAINING WALLS

### ITEM 32 32 23.8000 RETAINING WALL, SEGMENTAL

#### PART I: DESCRIPTION

- A. 8000 – Segmental retaining wall system design and installation to lines and grades established by Director.

#### PART II: GENERAL

- A. When ordered by Director, furnish and install a segmental retaining wall, in accordance with Director's instructions as determined in the field and the applicable Sections of City of Pittsburgh Specifications. The extent of the retaining wall is to conform to the orders of the Director given in the field.

#### PART III: PRODUCTS AND MATERIALS

- A. Concrete Segmental Retaining Wall (SRW) Units are Portland cement concrete blocks specifically designed for retaining wall applications:
  - 1. SRW to match existing segmental retaining walls that are adjacent to the site,
  - 2. VERSA-LOK Retaining Wall Units as manufactured by R.I. Lampus Company, or approved equal,
  - 3. Submit segmental retaining wall system for review and approval of Director prior to purchase and installation.
- B. Submit product information to Director for SRW selection of: Color, Finish and Unit Geometry.
- C. SRW units shall be interlocked with connection pins, designed with proper setback to provide 8:1 vertical-to-horizontal batter (a 7-degree cant from vertical).
- D. SRW units shall be capable of providing overlap of units on each successive course so that walls meeting at corner are interlocked and continuous. SRW units that require corners to be mitered shall not be allowed.
- E. SRW units shall be capable of providing a split-face, textured surface for all vertical surfaces that will be exposed after completion of wall, including any exposed sides and backs of units.
- F. SRW units shall be sound and free of cracks or other defects that would interfere with the proper placing of the unit or significantly impair the strength or permanence of the structure. Cracking or excessive chipping may be grounds for rejection. Units showing cracks longer than ½ inch shall not be used within the wall. Units showing chips visible at a distance of 30 feet from the wall shall not be used within the wall.
- G. Concrete used to manufacture SRW units shall have a minimum 28 days compressive strength of 3,000 psi and a maximum moisture absorption rate, by weight, of 8% as determined in accordance with ASTM C1372. Compressive strength test specimens shall conform to the saw-cut coupon provisions of ASTM C140.
- H. Cap adhesive shall meet the requirements of the retaining wall manufacturer.
- I. Geosynthetic Reinforcement:

1. The type, strength and placement location of the reinforcing geosynthetic shall be as determined by the Wall Design Engineer, as shown on the final, P.E.-sealed retaining wall plans.
  2. Geosynthetic reinforcement shall consist of geogrids or geotextiles manufactured as a soil reinforcement element. The manufacturers/suppliers of the geosynthetic reinforcement shall have demonstrated construction of similar size and types of segmental retaining walls on previous projects.
- J. Leveling Pad
1. Material for leveling pad shall consist of compacted 2A Subbase material a minimum of 6 inches in depth.
  2. Lean concrete with a strength of 200-300 psi and 3 inches thick maximum may also be used as a leveling pad material.
  3. The leveling pad should extend laterally at least a distance of 6 inches from the toe and heel of the lowermost SRW unit.
- K. Drainage Aggregate
1. #57 Coarse Aggregate.
- L. Drainage Pipe
1. The drainage collection pipe shall be a perforated or slotted PVC, or corrugated HDPE pipe. The drainage pipe may be wrapped with a geotextile to function as a filter.
  2. Drainage pipe shall be manufactured in accordance with ASTM D 3034 and/or
  3. ASTM D 1248.
- M. Reinforced (Infill) Soil
1. The maximum particle size of poorly-graded gravels (GP) (no fines) should not exceed 3/4 inch unless expressly approved by the Wall Design Engineer and the long-term design strength (LTDS) of the geosynthetic is reduced to account for additional installation damage from particles larger than this maximum.
  2. The reinforced soil material shall be free of debris. The plasticity of the fine fraction shall be less than 20.

#### **PART IV: CONSTRUCTION AND EXECUTION**

- A. Design for Segmental retaining wall system greater than 4 feet.
1. The design analysis for the retaining wall system with P.E.-sealed retaining wall plans prepared by the Wall Design Engineer shall consider the external stability against sliding and overturning, internal stability and facial stability of the reinforced soil mass and shall be in accordance with acceptable engineering practice and these specifications. The internal and external stability analysis shall be performed in accordance with the "NCMA Design Manual for Segmental Retaining Walls," using the recommended minimum factors of safety in this manual.
  2. Geotechnical Engineer shall perform bearing capacity, settlement estimates, and global stability analysis based on the final wall design provided by the Wall Design Engineer and coordinate any required changes with Wall Design Engineer.
  3. While vertical spacing between geogrid layers may vary, it shall not exceed 2.0 feet maximum in the wall design.

Housing Authority of the City of Pittsburgh  
Authority-wide Site Improvements

4. The geosynthetic placement in the wall design shall have 100% continuous coverage parallel to the wall face. Gapping between horizontally adjacent layers of geosynthetic (partial coverage) will not be allowed.
- B. Design for Segmental retaining wall system less than 4 feet
  1. Install per manufactures recommendations.
- C. Excavation
  1. Contractor shall excavate to the lines and grades shown on the project grading plans. Contractor shall take precautions to minimize over-excavation. Over-excavation shall be filled with compacted infill material, or as directed, at the Contractor's expense.
  2. Contractor shall verify location of existing structures and utilities prior to excavation. Contractor shall ensure all surrounding structures are protected from the effects of wall excavation. Excavation support, if required, is the responsibility of the Contractor.
- D. Foundation Preparation
  1. Foundation soil shall be proof-rolled and compacted to 95% standard Proctor density prior to placement of leveling pad materials. Soils not meeting the required strength shall be removed and replaced with infill soils.
- E. Leveling Pad Construction
  1. Granular leveling pad material shall be compacted to provide a firm, level bearing surface on which to place the first course of units. Well-graded sand can be used to smooth the top 1/4 inch to 1/2 inch of the leveling pad. Compaction will be with mechanical plate compactors to achieve 95% of maximum standard Proctor density (ASTM D 698).
  2. Leveling pad shall be placed as designed on the final, P.E.-sealed retaining wall plans or with a minimum thickness of 6 inches. The leveling pad should extend laterally at least a distance of 6 inches from the toe and heel of the lowermost SRW unit.
- F. SRW Unit Installation
  1. All SRW units shall be installed at the proper elevation and orientation as shown on the final, P.E.-sealed wall plans and details or as directed by the Wall Design Engineer. The SRW units shall be installed in general accordance with the manufacturer's recommendations. The specifications and drawings shall govern in any conflict between the two requirements.
  2. First course of SRW units shall be placed on the leveling pad. The units shall be leveled side-to-side, front-to-rear and with adjacent units, and aligned to ensure intimate contact with the leveling pad. The first course is the most important to ensure accurate and acceptable results. No gaps shall be left between the front of adjacent units. Alignment may be done by means of a string line or offset from base line to the back of the units.
  3. All excess debris shall be cleaned from top of units and the next course of units installed on top of the units below.
  4. Prior to placement of next course, the level and alignment of the units shall be checked and corrected where needed.

5. Layout of curves and corners shall be installed in accordance with the wall plan details or in general accordance with SRW manufacturer's installation guidelines. Walls meeting at corners shall be interlocked by overlapping successive courses.
  6. Repeated until reaching top of wall units, just below the height of the cap units. geosynthetic reinforcement, drainage materials, and reinforced backfill shall be placed in sequence with unit installation.
- G. Geosynthetic Reinforcement Placement
1. All geosynthetic reinforcement shall be installed at the proper elevation and orientation as shown on the final P.E.-sealed retaining wall plan profiles and details, or as directed by the Wall Design Engineer.
  2. At the elevations shown on the final plans, (after the units, drainage material and backfill have been placed to this elevation) the geosynthetic reinforcement shall be laid horizontally on compacted infill and on top of the concrete SRW units, to within 1 inch of the front face of the unit below. Embedment of the geosynthetic in the SRW units shall be consistent with SRW manufacturer's recommendations. Correct orientation of the geosynthetic reinforcement shall be verified by the Contractor to be in accordance with the geosynthetic manufacturer's recommendations. The highest-strength direction of the geosynthetic must be perpendicular to the wall face.
  3. Geosynthetic reinforcement layers shall be one continuous piece for their entire embedment length. Splicing of the geosynthetic in the design-strength direction (perpendicular to the wall face) shall not be permitted. Along the length of the wall, horizontally adjacent sections of geosynthetic reinforcement shall be butted in a manner to assure 100% coverage parallel to the wall face.
  4. Tracked construction equipment shall not be operated directly on the geosynthetic reinforcement. A minimum of 6 inches of backfill is required prior to operation of tracked vehicles over the geosynthetic. Turning should be kept to a minimum. Rubber-tired equipment may pass over the geosynthetic reinforcement at slow speeds (less than 5 mph).
  5. The geosynthetic reinforcement shall be free of wrinkles prior to placement of soil fill. The nominal tension shall be applied to the reinforcement and secured in place with staples, stakes or by hand tensioning until reinforcement is covered by 6 inches of fill.
- H. Drainage materials
1. Drainage aggregate shall be installed to the line, grades and sections shown on the final P.E.-sealed retaining wall plans. Drainage aggregate shall be placed to the minimum thickness shown on the construction plans between and behind units (a minimum of 1 cubic foot for each exposed square foot of wall face unless otherwise noted on the final wall plans).
  2. B. Drainage collection pipes shall be installed to maintain gravity flow of water outside the reinforced-soil zone. The drainage collection pipe shall daylight into a storm sewer or along a slope, at an elevation lower than the lowest point of the pipe within the aggregate drain.
- I. Backfill Placement

1. The reinforced backfill shall be placed as shown in the final wall plans in the maximum compacted lift thickness of 10 inches and shall be compacted to a minimum of 95% of standard Proctor density (ASTM D 698) at a moisture content within 2% of optimum. The backfill shall be placed and spread in such a manner as to eliminate wrinkles or movement of the geosynthetic reinforcement and the SRW units.
  2. Only hand-operated compaction equipment shall be allowed within 3 feet of the back of the wall units. Compaction within the 3 feet behind the wall units shall be achieved by at least three passes of a lightweight mechanical tamper, plate, or roller.
  3. At the end of each day's operation, the Contractor shall slope the last level of backfill away from the wall facing and reinforced backfill to direct water runoff away from the wall face.
  4. At completion of wall construction, backfill shall be placed level with final top of wall elevation. If final grading, paving, landscaping and/or storm drainage installation adjacent to the wall is not placed immediately after wall completion, temporary grading and drainage shall be provided to ensure water runoff is not directed at the wall nor allowed to collect or pond behind the wall until final construction adjacent to the wall is completed.
- J. SRW Caps
1. SRW caps shall be properly aligned and glued to underlying units with recommended and approved adhesive, a flexible, high-strength concrete adhesive. Rigid adhesive or mortar are not acceptable.
  2. Caps shall overhang the top course of units by 3/4 inch to 1 inch. Slight variation in overhang is allowed to correct alignment at the top of the wall.
- K. Construction Adjacent to Completed Wall
1. Heavy paving or grading equipment shall be kept a minimum of 3 feet behind the back of the wall face. Equipment with wheel loads in excess of 150 psf live load shall not be operated within 10 feet of the face of the retaining wall during construction adjacent to the wall. Care should be taken by the General Contractor to ensure water runoff is directed away from the wall structure until final grading and surface drainage collection systems are completed.

**PART V: MEASUREMENT AND PAYMENT**

**A. RETAINING WALL, SEGMENTAL. Square foot.**

1. Payment will be made at the Unit Price Bid per square foot of vertical projected face area from the top of the leveling pad to the top of the cap unit for a segmental retaining wall system furnished and installed.
2. Payment is full compensation for the work described for the item, including all necessary labor, tools, machinery, and materials required to complete the work.
3. Excavation and material removal and disposal is not included under this Item.
  - a. Excavation for Segmental Retaining wall: Payment will be made under Trench Excavation.

END OF SECTION 32 32 23

[THIS PAGE BLANK]

**SECTION 32 91 19 – LANDSCAPE GRADING**

**ITEM 32 91 19.1205 BORROW TOPSOIL**

**PART I: DESCRIPTION**

- A. 1205 – Topsoil, 4" Depth, on a prepared surface.

**PART II: GENERAL**

- A. When ordered by Director, furnish and place borrow topsoil, in accordance with Director's instructions as determined in the field and the applicable Sections of City of Pittsburgh Specifications. The extent of the top soil placement is to conform to the orders of the Director given in the field.
- B. Borrow topsoil as specified in PADOT Publication 408, Section 802 – Topsoil Furnished and placed. Conform PADOT specifications to applicable sections of City of Pittsburgh Specifications.

**PART III: PRODUCTS AND MATERIALS**

- A. Provide products and materials specified in PADOT 408, Section 802.2 Material or approved type.

**PART IV: CONSTRUCTION AND EXECUTION**

- A. Execute work as specified in PADOT 408, Section 802.3 Construction.

**PART V: MEASUREMENT AND PAYMENT**

**A. BORROW TOPSOIL. Cubic Yard.**

1. Payment will be made at the Unit Price Bid per cubic yard furnished and placed.
2. Payment is full compensation for the work described for the item, including all necessary labor, tools, machinery, and materials required to complete the work.

END OF SECTION 32 91 19

[THIS PAGE BLANK]



SECTION 32 92 00 – TURF AND GRASSES

**PART I: GENERAL**

1. RELATED DOCUMENTS
  - A. Drawings and general provisions of the Contract, including General and Supplementary Conditions and Division 01 Specification Sections, apply to this Section.
2. SUMMARY
  - A. Section Includes:
    1. Seeding.
    2. Mulch
    3. Turf renovation.
    4. Erosion-control material(s).
3. ACTION SUBMITTALS
  - A. Product Data: For each type of product indicated.
    1. Pesticides and Herbicides: Include product label and manufacturer's application instructions specific to this Project.
4. INFORMATIONAL SUBMITTALS
  - A. Certification of Grass Seed: From seed vendor for each grass-seed mixture stating the botanical and common name, percentage by weight of each species and variety, and percentage of purity, germination, and weed seed. Include the year of production and date of packaging.
5. QUALITY ASSURANCE
  - A. Soil-Testing Laboratory Qualifications: An independent laboratory or university laboratory, recognized by the State Department of Agriculture, with the experience and capability to conduct the testing indicated and that specializes in types of tests to be performed.
6. DELIVERY, STORAGE, AND HANDLING
  - A. Seed and Other Packaged Materials: Deliver packaged materials in original, unopened containers showing weight, certified analysis, name and address of manufacturer, and indication of conformance with state and federal laws, as applicable.
  - B. Bulk Materials:
    1. Do not dump or store bulk materials near structures, utilities, walkways and pavements, or on existing turf areas or plants.
    2. Provide erosion-control measures to prevent erosion or displacement of bulk materials, discharge of soil-bearing water runoff, and airborne dust reaching adjacent properties, water conveyance systems, or walkways.
7. PROJECT CONDITIONS
  - A. Weather Limitations: Proceed with planting only when existing and forecasted weather conditions permit planting to be performed when beneficial and optimum results may be obtained. Apply products during favorable weather conditions according to manufacturer's written instructions.
8. MAINTENANCE SERVICE
  - A. Initial Turf Maintenance Service: Provide full maintenance by skilled employees of landscape Installer. Maintain as required in Part 3. Begin maintenance immediately after each area is planted and continue until acceptable turf is established but for not less than the following periods:
    1. Seeded Turf: 60 days from date of planting completion.

- a. When initial maintenance period has not elapsed before end of planting season, or if turf is not fully established, continue maintenance during next planting season.

**PART II: PRODUCTS**

1. SEED

- A. Grass Seed: Fresh, clean, dry, new-crop seed complying with AOSA's "Journal of Seed Technology; Rules for Testing Seeds" for purity and germination tolerances.
- B. Grass Seed Mix: Proprietary seed mix developed by Peter J. Landschoot, associate professor of turf grass science at Penn State University and as follows:
  1. Products: Subject to compliance with requirements, provide the following:
    - a. A mixture of 50 to 60 percent Kentucky Bluegrass, 30 to 40 percent fine fescue, (creeping red fescue, red fescue, or Chewings Fescue) and no more than 10 to 20 percent perennial ryegrass.

2. PLANTING SOILS

- A. Planting Soil for Turf Grass: Existing, native surface topsoil formed under natural conditions with the duff layer retained during excavation process and stockpiled on-site. Verify suitability of native surface topsoil to produce viable planting soil. Clean soil of roots, plants, sod, stones, clay lumps, and other extraneous materials harmful to plant growth.

3. TURF MULCHES

- A. Straw Mulch: Provide air-dry, clean, mildew- and seed-free, salt hay or threshed straw of wheat, rye, oats, or barley.
- B. Peat mulch may be required if seeded turf is subject to hot, dry weather or drying winds within 30 days of planting.

4. TREE MULCH

- A. Wood Chips: Hardwood chips, air-dry, clean, mildew- and seed-free, medium brown in color. Submit sample for approval. Redwood and Walnut chip mulches are not permitted due to allelopathic effects.

5. EROSION-CONTROL MATERIALS

- A. Erosion-Control Blankets: Biodegradable wood excelsior, straw, or coconut-fiber mat enclosed in a photodegradable plastic mesh. Include manufacturer's recommended steel wire staples, 6 inches long.

**PART III: EXECUTION**

1. EXAMINATION

- A. Examine areas to be planted for compliance with requirements and other conditions affecting performance.
  1. Verify that no foreign or deleterious material or liquid such as paint, paint washout, concrete slurry, concrete layers or chunks, cement, plaster, oils, gasoline, diesel fuel, paint thinner, turpentine, tar, roofing compound, or acid has been deposited in soil within a planting area.
  2. Do not mix or place soils and soil amendments in frozen, wet, or muddy conditions.
  3. Suspend soil spreading, grading, and tilling operations during periods of excessive soil moisture until the moisture content reaches acceptable levels to attain the required results.
  4. Uniformly moisten excessively dry soil that is not workable and which is too dusty.
- B. Proceed with installation only after unsatisfactory conditions have been corrected.
- C. If contamination by foreign or deleterious material or liquid is present in soil within a planting area, remove the soil and contamination as directed by Architect and replace with new planting soil.

2. PREPARATION

- A. Protect structures, utilities, sidewalks, pavements, and other facilities, trees, shrubs, and plantings from damage caused by planting operations.
    1. Protect grade stakes set by others until directed to remove them.
  - B. Install erosion-control measures to prevent erosion or displacement of soils and discharge of soil-bearing water runoff or airborne dust to adjacent properties and walkways.
3. TURF AREA PREPARATION
- A. Limit turf subgrade preparation to areas to be planted.
  - B. Unchanged Subgrades: If turf is to be planted in areas unaltered or undisturbed by excavating, grading, or surface-soil stripping operations, prepare surface soil as follows:
    1. Remove existing grass, vegetation, and turf. Do not mix into surface soil.
    2. Loosen surface soil to a depth of at least 6 inches. Apply existing, native, surface topsoil, amendments and initial fertilizers required for establishing new turf and mix thoroughly into top 4 inches of soil. Till soil to a homogeneous mixture of fine texture.
    3. Remove stones larger than 1 inch in any dimension and sticks, roots, trash, and other extraneous matter.
    4. Legally dispose of waste material, including grass, vegetation, and turf, off Owner's property.
  - C. Finish Grading: Grade planting areas to a smooth, uniform surface plane with loose, uniformly fine texture. Grade to within plus or minus 1/2 inch of finish elevation. Roll and rake, remove ridges, and fill depressions to meet finish grades. Limit finish grading to areas that can be planted in the immediate future.
  - D. Moisten prepared area before planting if soil is dry. Water thoroughly and allow surface to dry before planting. Do not create muddy soil.
  - E. Before planting, obtain Architect's acceptance of finish grading; restore planting areas if eroded or otherwise disturbed after finish grading.
4. PREPARATION FOR EROSION-CONTROL MATERIALS
- A. Prepare area as specified in "Turf Area Preparation" Article.
  - B. For erosion-control blanket or mesh, install from top of slope, working downward, and as recommended by material manufacturer for site conditions. Fasten as recommended by material manufacturer.
  - C. Moisten prepared area before planting if surface is dry. Water thoroughly and allow surface to dry before planting. Do not create muddy soil.
5. SEEDING
- A. Sow seed with spreader or seeding machine. Do not broadcast or drop seed when wind velocity exceeds 5 mph. Evenly distribute seed by sowing equal quantities in two directions at right angles to each other.
    1. Do not use wet seed or seed that is moldy or otherwise damaged.
    2. Do not seed against existing trees. Limit extent of seed to outside edge of planting saucer.
  - B. Sow seed at a total rate of 5 to 8 lb/1000 sq. ft.
  - C. Rake seed lightly into top 1/8 inch of soil, roll lightly, and water with fine spray.
  - D. Protect seeded areas with slopes exceeding 1:4 with erosion-control blankets installed and stapled according to manufacturer's written instructions.
  - E. For slopes not exceeding 1:4, protect seeded areas with straw mulch.
6. TURF RENOVATION
- A. Renovate existing turf damaged by Contractor's operations, such as storage of materials or equipment and movement of vehicles.
    1. Reestablish turf where settlement or washouts occur or where minor regrading is required.
    2. Install new planting soil as required.

- B. Remove sod and vegetation from diseased or unsatisfactory turf areas; do not bury in soil.
  - C. Remove topsoil containing foreign materials such as oil drippings, fuel spills, stones, gravel, and other construction materials resulting from Contractor's operations, and replace with new planting soil.
  - D. Mow, dethatch, core aerate, and rake existing turf.
  - E. Remove weeds before seeding. Where weeds are extensive, apply selective herbicides as required. Do not use pre-emergence herbicides.
  - F. Remove waste and foreign materials, including weeds, soil cores, grass, vegetation, and turf, and legally dispose of them off Owner's property.
  - G. Till stripped, bare, and compacted areas thoroughly to a soil depth of 6 inches.
  - H. Apply soil amendments and initial fertilizers required for establishing new turf and mix thoroughly into top 4 inches of existing soil. Install new planting soil to fill low spots and meet finish grades.
  - I. Apply seed and protect with straw mulch as required for new turf.
  - J. Protect seeded areas with slopes exceeding 1:4 with erosion-control blankets installed and stapled according to manufacturer's written instructions.
  - K. Water newly planted areas and keep moist until new turf is established.
7. TURF MAINTENANCE
- A. Maintain and establish turf by watering, fertilizing, weeding, mowing, trimming, replanting, and performing other operations as required to establish healthy, viable turf. Roll, regrade, and replant bare or eroded areas and remulch to produce a uniformly smooth turf. Provide materials and installation the same as those used in the original installation.
    - 1. Fill in as necessary soil subsidence that may occur because of settling or other processes. Replace materials and turf damaged or lost in areas of subsidence.
    - 2. In areas where mulch has been disturbed by wind or maintenance operations, add new mulch and anchor as required to prevent displacement.
  - B. Watering: Install and maintain temporary piping, hoses, and turf-watering equipment to convey water from sources and to keep turf uniformly moist to a depth of 4 inches.
    - 1. Schedule watering to prevent wilting, puddling, erosion, and displacement of seed or mulch. Lay out temporary watering system to avoid walking over muddy or newly planted areas.
    - 2. Water turf with fine spray at a minimum rate of 1 inch per week unless rainfall precipitation is adequate.
  - C. Mow turf as soon as top growth is tall enough to cut. Repeat mowing to maintain specified height without cutting more than 1/3 of grass height. Remove no more than 1/3 of grass-leaf growth in initial or subsequent mowings. Do not delay mowing until grass blades bend over and become matted. Do not mow when grass is wet. Schedule initial and subsequent mowings to maintain the following grass height:
    - 1. Mow grass to a height of approximately 2 inches.
8. SATISFACTORY TURF
- A. Turf installations shall meet the following criteria as determined by Architect:
    - 1. Satisfactory Seeded Turf: At end of maintenance period, a healthy, uniform, close stand of grass has been established, free of weeds and surface irregularities, with coverage exceeding 90 percent over any 10 sq. ft. and bare spots not exceeding 5 by 5 inches.
  - B. Use specified materials to reestablish turf that does not comply with requirements and continue maintenance until turf is satisfactory.
9. MULCH APPLICATION AT TREES

Housing Authority of the City of Pittsburgh  
Authority-wide Site Improvements

- A. Apply mulch from the trunk to the dripline, directly to the soil surface. Do not use landscape fabric to separate the mulch from the soil. Mulch layer shall be 2 inches to 4 inches in depth.
  - B. Additional mulch shall be added to maintain a 2 inch to 4 inch depth during turf grass establishment period.
  - C. Do not place mulch directly against the trunk. Mulch will retain too much moisture against the trunk, potentially resulting in disease problems.
10. CLEANUP AND PROTECTION
- A. Promptly remove soil and debris created by turf work from paved areas. Clean wheels of vehicles before leaving site to avoid tracking soil onto roads, walks, or other paved areas.
  - B. Erect temporary fencing or barricades and warning signs as required to protect newly planted areas from traffic. Maintain fencing and barricades throughout initial maintenance period and remove after plantings are established.
  - C. Remove nondegradable erosion-control measures after grass establishment period.

END OF SECTION 32 92 00

THIS PAGE BLANK

**SECTION 32 92 13 – HYDRO-MULCHING**

**ITEM 32 92 13.0024 MULCHING**

**PART I: DESCRIPTION**

- A. 0024 – Wood fiber mulching.

**PART II: GENERAL**

- A. When ordered by Director, furnish, place and maintain wood fiber mulching, in accordance with Director's instructions as determined in the field and the applicable Sections of City of Pittsburgh Specifications. The extent of the mulching is to conform to the orders of the Director given in the field.
- B. Mulching as specified in PADOT Publication 408, Section 805 – Mulching. Conform PADOT specifications to applicable sections of City of Pittsburgh Specifications.

**PART III: PRODUCTS AND MATERIALS**

- A. Provide products and materials specified in PADOT 408, Section 805.2 Material or approved type.

**PART IV: CONSTRUCTION AND EXECUTION**

- A. Execute work as specified in PADOT 408, Section 805.3 Construction.

**PART V: MEASUREMENT AND PAYMENT**

**A. MULCHING. Ton.**

1. Payment will be made at the Unit Price Bid per ton of wood fiber mulching furnished and placed.
2. Payment is full compensation for the work described for the item, including all necessary labor, tools, machinery, and materials required to complete the work.

END OF SECTION 32 92 13

[THIS PAGE BLANK]



## SECTION 32 94 43 – TREE GRATES

### ITEM 32 94 43.0100 TREE GRATE

#### PART I: DESCRIPTION

- A. 0100 – 48” square cast iron tree grate and tree grate frame.

#### PART II: GENERAL

- A. When ordered by Director, furnish and install tree grate and frame, in accordance with Director’s instructions as determined in the field and the applicable Sections of City of Pittsburgh Specifications.

#### PART III: PRODUCTS AND MATERIALS

- A. Tree grate and frames:
  - 1. Match the existing tree grate and frames that are adjacent to the site,
  - 2. Comply with City of Pittsburgh Standards or
  - 3. Submit drawings of tree grates and frames for review and approval of Director prior to purchase and installation.

#### PART IV: CONSTRUCTION AND EXECUTION

- A. Examination
  - 1. Do not begin installation until substrate is properly prepared.
- B. Preparation
  - 1. Clean surfaces thoroughly prior to installation
  - 2. Prepare surfaces using the methods recommended by the manufacturer for achieving the best result for the substrate under the project conditions.
- C. Installation
  - 1. Coordinate installation of the tree grate system in relation to and with adjacent construction.
  - 2. Install frame per manufacturer details and recommendations:
    - a. Flush and leveled with surrounding pavement surface.
    - b. Frames MUST NOT slope in more than one direction.
  - 3. Install grate on frame clean of concrete and debris.
    - a. Install flush to frame and adjacent surface. If needed, grind pads on underside of tree grates to level and prevent rocking in frame.

#### PART V: MEASUREMENT AND PAYMENT

- A. **TREE GRATE. Each.**
  - 1. Payment will be made at the Unit Price Bid per each tree grate and frame set furnished and installed.
  - 2. Payment is full compensation for the work described for the item, including all necessary labor, tools, machinery, and materials required to complete the work.

END OF SECTION 32 94 43

[THIS PAGE BLANK]

**SECTION 33 12 13 – WATER SERVICE CONNECTIONS**

**ITEM 33 12 13.1291 PRIVATE WATER SERVICE**

**PART I: DESCRIPTION**

- A. 1291 – PWSA, Water service line for a single family residence.

**PART II: GENERAL**

- A. When ordered by Director, furnish and install or repair water service line, in accordance with Director's instructions as determined in the field and the applicable Sections of City of Pittsburgh Specifications.
- B. Water service line per City of Pittsburgh Specification Section 1291 and other applicable sections of City of Pittsburgh Specifications.
- C. Water service line to comply with Pittsburgh Water and Sewer Authority requirements.

**PART III: PRODUCTS AND MATERIALS [NOT USED]**

**PART IV: CONSTRUCTION AND EXECUTION [NOT USED]**

**PART V: MEASUREMENT AND PAYMENT**

**A. PRIVATE WATER SERVICE. Linear Foot.**

1. Payment will be made at the Unit Price Bid per linear foot for furnishing and installing a PWSA approved water service line for a single family residence including PWSA permitting and approval of connection.
2. Payment is full compensation for the work described for the item, including all necessary labor, tools, machinery, and materials required to complete the work.
3. Excavation and material removal and disposal is not included under this Item.
  - a. Excavation as directed: Payment will be made under Sewer Excavation.

END OF SECTION 33 12 13

[THIS PAGE BLANK]

**SECTION 33 33 13 – SANITARY UTILITY SEWERAGE**

**ITEM 33 33 13.1237 SANITARY SEWER, HOUSE LATERAL**

**PART I: DESCRIPTION**

- A. 1237 – PWSA, Sanitary sewer lateral for a single family residence.

**PART II: GENERAL**

- A. When ordered by Director, furnish and install or repair sanitary sewer lateral, in accordance with Director's instructions as determined in the field and the applicable Sections of City of Pittsburgh Specifications.
- B. Sanitary Sewer, House Lateral City of Pittsburgh Specification Section 1237 and other applicable sections of City of Pittsburgh Specifications.
- C. Sanitary sewer lateral to comply with Pittsburgh Water and Sewer Authority requirements.

**PART III: PRODUCTS AND MATERIALS [NOT USED]**

**PART IV: CONSTRUCTION AND EXECUTION [NOT USED]**

**PART V: MEASUREMENT AND PAYMENT**

**A. SANITARY SEWER, HOUSE LATERAL. Linear Foot.**

1. Payment will be made at the Unit Price Bid per linear foot for furnishing and installing a PWSA approved sanitary sewer lateral for a single family residence including PWSA permitting and approval of connection.
2. Payment is full compensation for the work described for the item, including all necessary labor, tools, machinery, and materials required to complete the work.
3. Excavation and material removal and disposal is not included under this Item.
  - a. Excavation as directed: Payment will be made under Sewer Excavation.

END OF SECTION 33 33 13

[THIS PAGE BLANK]

**SECTION 33 41 13 – PUBLIC STORM UTILITY DRAINAGE PIPING**

**ITEM 33 41 13.0001 6" THERMOPLASTIC PIPE, PADOT GROUP I, 15' MAX FILL – 1.5' MIN. COVER**

**ITEM 33 41 13.0311 12" THERMOPLASTIC PIPE, PADOT GROUP I, 15' MAX. FILL – 1.5' MIN. COVER**

**ITEM 33 41 13.0313 18" THERMOPLASTIC PIPE, PADOT GROUP I, 15' MAX. FILL – 1.5' MIN. COVER**

**ITEM 33 41 13.0315 24" THERMOPLASTIC PIPE, PADOT GROUP I, 15' MAX. FILL – 1.5' MIN. COVER**

**PART I: DESCRIPTION**

- A. 0001 – 6” thermoplastic pipe, PADOT Group I, 15’ maximum fill, 1.5 minimum cover, including bedding and back fill.
- B. 0311 – 12” thermoplastic pipe, PADOT Group I, 15’ maximum fill, 1.5 minimum cover, including bedding and back fill.
- C. 0313 – 18” thermoplastic pipe, PADOT Group I, 15’ maximum fill, 1.5 minimum cover, including bedding and back fill.
- D. 0315 – 24” thermoplastic pipe, PADOT Group I, 15’ maximum fill, 1.5 minimum cover, including bedding and back fill.

**PART II: GENERAL**

- A. When ordered by Director, furnish and install thermoplastic pipe, in accordance with Director’s instructions as determined in the field and the applicable Sections of City of Pittsburgh Specifications.
- B. The extent of the pipe is to conform to the orders of the Director given in the field.
- C. Thermoplastic pipe as specified in PADOT Publication 408, Section 601 – Pipe Culverts and as shown on Standard Drawing RC 30M – Subsurface Drains. Conform PADOT specifications to applicable sections of City of Pittsburgh Specifications.

**PART III: PRODUCTS AND MATERIALS**

- A. Provide products and materials specified in PADOT 408, Section 601.2 Material or approved type.

**PART IV: CONSTRUCTION AND EXECUTION**

- A. Execute work as specified in PADOT 408, Section 601.3 Construction.

**PART V: MEASUREMENT AND PAYMENT**

- A. **6" THERMOPLASTIC PIPE, PADOT GROUP I, 15' MAXIMUM FILL, 1.5' MINIMUM COVER. Linear Foot.**
  - 1. Payment will be made at the Unit Price Bid per linear foot of pipe furnished and installed including bedding material and the back fill per PADOT standard drawing.
  - 2. Payment is full compensation for the work described for the item, including all necessary labor, tools, machinery, and materials required to complete the work.
  - 3. Excavation and material removal and disposal is not included under this Item.

a. Excavation as directed: Payment will be made under Sewer Excavation.

**B. 12" THERMOPLASTIC PIPE, PADOT GROUP I, 15' MAXIMUM FILL, 1.5' MINIMUM COVER. Linear Foot.**

1. Payment will be made at the Unit Price Bid per linear foot of pipe furnished and installed including bedding material and the back fill per PADOT standard drawing.
2. Payment is full compensation for the work described for the item, including all necessary labor, tools, machinery, and materials required to complete the work.
3. Excavation and material removal and disposal is not included under this Item.

a. Excavation as directed: Payment will be made under Sewer Excavation.

**C. 18" THERMOPLASTIC PIPE, PADOT GROUP I, 15' MAXIMUM FILL, 1.5' MINIMUM COVER. Linear Foot.**

1. Payment will be made at the Unit Price Bid per linear foot of pipe furnished and installed including bedding material and the back fill per PADOT standard drawing.
2. Payment is full compensation for the work described for the item, including all necessary labor, tools, machinery, and materials required to complete the work.
3. Excavation and material removal and disposal is not included under this Item.

a. Excavation as directed: Payment will be made under Sewer Excavation.

**D. 24" THERMOPLASTIC PIPE, PADOT GROUP I, 15' MAXIMUM FILL, 1.5' MINIMUM COVER. Linear Foot.**

1. Payment will be made at the Unit Price Bid per linear foot of pipe furnished and installed including bedding material and the back fill per PADOT standard drawing.
2. Payment is full compensation for the work described for the item, including all necessary labor, tools, machinery, and materials required to complete the work.
3. Excavation and material removal and disposal is not included under this Item.

a. Excavation as directed: Payment will be made under Sewer Excavation.

END OF SECTION 33 41 13



**SECTION 33 46 16 – SUBDRAINAGE PIPING**

**ITEM 33 46 16.0100 BROKEN STONE PIPE SUBDRAIN, CURB**

**ITEM 33 46 16.0200 BROKEN STONE PIPE SUBDRAIN, PAVEMENT**

**ITEM 33 46 16.1010 BROKEN STONE SUBSURFACE DRAIN**

**PART I: DESCRIPTION**

- A. 0100 – 4" PVC perforated underdrain pipe and #57 aggregate with PADOT Class 1 Geotextile beneath a curb.
- B. 0200 – 4" PVC perforated underdrain pipe and #57 aggregate with PADOT Class 1 Geotextile beneath pavement.
- C. 1010 – Subsurface drain of #8 Aggregate coarse aggregate, PADOT Type C or better, and PADOT Class 1 Geotextile.

**PART II: GENERAL**

- A. When ordered by Director, furnish and install drain, in accordance with Director's instructions as determined in the field and the applicable Sections of City of Pittsburgh Specifications.
- B. The extent of drains is to conform to the orders of the Director given in the field.
- C. Broken Stone and Pipe Subdrain per City of Pittsburgh Specification Section 423 and other applicable sections of City of Pittsburgh Specifications.
- D. Broken Stone Subsurface Drains per City of Pittsburgh Specification Section 424 and other applicable sections of City of Pittsburgh Specifications.

**PART III: PRODUCTS AND MATERIALS**

- A. Provide the following products and materials specified in PADOT 408, Section 610.2 Material or approved type.
  - 1. Pipes: Provide perforated PVC Pipe.
  - 2. Geotextile Fabric: Provide Class 1 Geotextile.
- B. Provide the following products and materials specified in PADOT 408, Section 612.2 Material or approved type.
  - 1. Aggregate: Coarse Aggregate, Type C or Better
    - a. No. 57 Aggregate for pipe subdrains.
    - b. No. 8 Aggregate for subsurface drains.

**PART IV: CONSTRUCTION AND EXECUTION [NOT USED]**

**PART V: MEASUREMENT AND PAYMENT**

- A. **BROKEN STONE PIPE SUBDRAIN, CURB. Linear Foot.**
  - 1. Payment will be made at the Unit Price Bid per linear foot for 4" perforated PVC, #57 aggregate with PADOT Class 1 geotextile for broken stone pipe subdrain beneath curb.
  - 2. Payment is full compensation for the work described for the item, including all necessary labor, tools, machinery, and materials required to complete the work.
  - 3. Excavation and material removal and disposal is not included under this Item.
    - a. Excavation for subdrain: Payment will be made under Trench Excavation.

**B. BROKEN STONE PIPE SUBDRAIN, PAVEMENT. Linear Foot.**

1. Payment will be made at the Unit Price Bid per linear foot for 4" perforated PVC, #57 aggregate with PADOT Class 1 geotextile for broken stone pipe subdrain beneath pavement.
2. Payment is full compensation for the work described for the item, including all necessary labor, tools, machinery, and materials required to complete the work.
3. Excavation and material removal and disposal is not included under this Item.
  - a. Excavation for subdrain: Payment will be made under Trench Excavation.

**C. BROKEN STONE SUBSURFACE DRAIN. Cubic Yard.**

1. Payment will be made at the Unit Price Bid per cubic yard for #8 aggregate or better with PADOT Class 1 geotextile for broken stone subsurface drain.
2. Payment is full compensation for the work described for the item, including all necessary labor, tools, machinery, and materials required to complete the work.
3. Excavation and material removal and disposal is not included under this Item.
  - a. Excavation for subsurface drain: Payment will be made under Trench Excavation.

END OF SECTION 33 46 16

**SECTION 33 49 13 – STORM DRAINAGE MANHOLES, FRAMES, AND COVERS**

**ITEM 33 49 13.0100 ALTERATION AND ADJUSTMENT OF CITY OF PITTSBURGH  
CATCH BASINS AND INLETS**

**ITEM 33 49 13.0200 ALTERATION AND ADJUSTMENT OF CITY OF PITTSBURGH  
MANHOLES**

**PART I: DESCRIPTION**

- A. 0100 – Grade adjustment or alteration in City of Pittsburgh Catch Basins and Inlets.
- B. 0200 – Grade adjustment or alteration in City of Pittsburgh manholes.

**PART II: GENERAL**

- A. When ordered by Director, remove casting and incidental masonry, alter and adjust to grade, in accordance with Director's instructions as determined in the field and the applicable Sections of City of Pittsburgh Specifications.
- B. Alterations and Adjustments per City of Pittsburgh Specification Section 1259 and other applicable sections of City of Pittsburgh Specifications.

**PART III: PRODUCTS AND MATERIALS [NOT USED]**

**PART IV: CONSTRUCTION AND EXECUTION [NOT USED]**

**PART V: MEASUREMENT AND PAYMENT**

**A. ALTERATION AND ADJUSTMENT OF CITY OF PITTSBURGH CATCH  
BASINS AND INLETS. Linear Vertical Foot.**

- 1. Payment will be made at the Unit Price Bid per linear vertical foot for adjustments and alterations in vertical height to finished grade for catch basins and inlets. Payment will be made to the nearest 0.1 foot, except that heights less than the first foot will be paid for as 1 vertical foot.
- 2. Payment is full compensation for the work described for the item, including all necessary labor, tools, machinery, and materials required to complete the work.

**B. ALTERATION AND ADJUSTMENT OF CITY OF PITTSBURGH MANHOLES.  
Linear Vertical Foot.**

- 1. Payment will be made at the Unit Price Bid per linear vertical foot for adjustments and alterations in vertical height to finished grade for manholes. Payment will be made to the nearest 0.1 foot, except that heights less than the first foot will be paid for as 1 vertical foot.
- 2. Payment is full compensation for the work described for the item, including all necessary labor, tools, machinery, and materials required to complete the work.

**ITEM 33 49 13.1100 PARTIAL RECONSTRUCTION OF CITY OF PITTSBURGH CATCH  
BASINS AND INLETS**

**PART I: DESCRIPTION**

- A. 1100 – Removal of material to top of stench plate for catch basins or the invert of the outlet pipe for inlets and rebuild with new masonry to the lines and grades determined in the field.

**PART II: GENERAL**

- A. When ordered by Director, demolish to reference point and rebuild catch basin or inlet, in accordance with Director's instructions as determined in the field and the applicable Sections of City of Pittsburgh Specifications.
- B. Reconstruction City of Pittsburgh Specification Section 1260 and other applicable sections of City of Pittsburgh Specifications.

**PART III: PRODUCTS AND MATERIALS [NOT USED]**

**PART IV: CONSTRUCTION AND EXECUTION [NOT USED]**

**PART V: MEASUREMENT AND PAYMENT**

**A. PARTIAL RECONSTRUCTION OF CITY OF PITTSBURGH CATCH BASINS  
AND INLETS. Linear Vertical Foot.**

- 1. Payment will be made at the Unit Price Bid per linear vertical foot for reconstructed for catch basins or inlets including cement mortar of the insides, removal and storage of casting and placing and filling of casting to be reset. Payment will be made to the nearest 0.1 foot, except that heights less than the first foot will be paid for as 1 vertical foot.
- 2. Payment is full compensation for the work described for the item, including all necessary labor, tools, machinery, and materials required to complete the work.

**ITEM 33 49 13.2300 CITY OF PITTSBURGH CASTINGS**

**PART I: DESCRIPTION**

- A. 2300 – Replacement casting required for City of Pittsburgh manholes, catch basins, storm inlets and modifications required to be placed in City Structures.

**PART II: GENERAL**

- A. When ordered by Director, furnish and install castings, in accordance with Director's instructions as determined in the field and the applicable Sections of City of Pittsburgh Specifications.
- B. Castings per City of Pittsburgh Specification Section 1255 and other applicable sections of City of Pittsburgh Specifications.

**PART III: PRODUCTS AND MATERIALS**

- A. Casting will not be furnished by the City.

**PART IV: CONSTRUCTION AND EXECUTION [NOT USED]**

**PART V: MEASUREMENT AND PAYMENT**

- A. **CITY OF PITTSBURGH CASTINGS. Each.**
  - 1. Payment will be made at the Unit Price Bid per each casting furnished and installed.
  - 2. Payment is full compensation for the work described for the item, including all necessary labor, tools, machinery, and materials required to complete the work.

**ITEM 33 49 13.2500 PADOT STANDARD MANHOLE**

**ITEM 33 49 13.2714 PADOT TYPE C CONCRETE TOP UNIT AND ADA COMPLIANT  
GRATE**

**ITEM 33 49 13.2734 PADOT TYPE M CONCRETE TOP UNIT ADA COMPLIANT GRATE**

**ITEM 33 49 13.2850 PADOT STANDARD INLET BOX, HEIGHT  $\leq$  10'**

**PART I: DESCRIPTION**

- A. 2500 – PADOT standard manhole, 4' dia., including 12" compacted aggregate base, manhole cover and frame, backfill and miscellaneous items required for the construction of the manhole.
- B. 2714 – PADOT Type C, concrete top unit and ADA compliant grate including grade adjustment ring, if required.
- C. 2734 – PADOT Type M, concrete top unit and ADA compliant grate including grade adjustment ring, if required.
- D. 2850 – PADOT standard inlet box with a height less than or equal to 10' including 12" compacted aggregate base, backfill and miscellaneous items required for the construction of the inlet.

**PART II: GENERAL**

- A. When ordered by Director, furnish and install a manhole or inlet, in accordance with Director's instructions as determined in the field and the applicable Sections of City of Pittsburgh Specifications.
- B. Manhole and inlets as specified in PADOT Publication 408, Section 605 – Endwalls, Inlet, Manholes, and Spring Boxes and as shown on Standard Drawings: RC 39M – Standard Manholes, RC 45M - Inlet Tops, Grates and Frames and RC 46M – Inlet Boxes. Conform PADOT specifications to applicable sections of City of Pittsburgh Specifications.

**PART III: PRODUCTS AND MATERIALS**

- A. Provide products and materials specified in PADOT 408, Section 605.2 Material or approved type.
  1. Grate: ADA Compliant Grate
  2. Manhole Cover: Per City of Pittsburgh Specifications – Castings, Section 1255.

**PART IV: CONSTRUCTION AND EXECUTION**

- A. Execute work as specified in PADOT 408, Section 605.3 Construction.

**PART V: MEASUREMENT AND PAYMENT**

**A. PADOT STANDARD MANHOLE. Each.**

1. Payment will be made at the Unit Price Bid per each standard manhole furnished and installed including 12" compacted aggregate base, manhole cover and frame, backfill and miscellaneous items required for the construction of the manhole.
2. Payment is full compensation for the work described for the item, including all necessary labor, tools, machinery, and materials required to complete the work.
3. Excavation and material removal and disposal is not included under this Item.
  - a. Excavation as directed: Payment will be made under Sewer Excavation.

**B. PADOT TYPE C CONCRETE TOP UNIT AND ADA COMPLIANT GRATE.**

**Each.**

1. Payment will be made at the Unit Price Bid per each set of top unit and grate furnished and installed at grade including grade adjustment ring, if required for the installation of top unit.
2. Payment is full compensation for the work described for the item, including all necessary labor, tools, machinery, and materials required to complete the work.

**C. PADOT TYPE M CONCRETE TOP UNIT ADA COMPLIANT GRATE. Each.**

1. Payment will be made at the Unit Price Bid per each set of top unit and grate furnished and installed at grade including grade adjustment ring, if required for the installation of top unit.
2. Payment is full compensation for the work described for the item, including all necessary labor, tools, machinery, and materials required to complete the work.

**D. PADOT STANDARD INLET BOX, HEIGHT  $\leq$  10'. Each.**

1. Payment will be made at the Unit Price Bid per each standard inlet furnished and installed including 12" compacted aggregate base, backfill and miscellaneous items required for the construction of the inlet.
2. Payment is full compensation for the work described for the item, including all necessary labor, tools, machinery, and materials required to complete the work.
3. Excavation and material removal and disposal is not included under this Item.
  - a. Excavation as directed: Payment will be made under Sewer Excavation.

**ITEM 33 49 13.6061 GRADE ADJUSTMENT OF EXISTING PADOT INLET**

**ITEM 33 49 13.6062 GRADE ADJUSTMENT OF EXISTING PADOT MANHOLE**

**PART I: DESCRIPTION**

- A. 6061 – Grade adjustment of existing PADOT inlet for vertical height 6” or less.
- B. 6062 – Grade adjustment of existing PADOT manhole for vertical height 6” or less.

**PART II: GENERAL**

- A. When ordered by Director, grade adjust inlet or manhole, in accordance with Director’s instructions as determined in the field and the applicable Sections of City of Pittsburgh Specifications.
- B. The extent of adjustment is to conform to the Director’s orders given in the field.
- C. Grade adjustments as specified in PADOT Publication 408, Section 606 – Grade Adjustment of Existing Miscellaneous Structures. Conform PADOT specifications to applicable sections of City of Pittsburgh Specifications.

**PART III: PRODUCTS AND MATERIALS**

- A. Provide products and materials specified in PADOT 408, Section 606.2 Material or approved type.

**PART IV: CONSTRUCTION AND EXECUTION**

- A. Execute work as specified in PADOT 408, Section 606.3 Construction.

**PART V: MEASUREMENT AND PAYMENT**

**A. GRADE ADJUSTMENT OF EXISTING PADOT INLET. Each.**

- 1. Payment will be made at the Unit Price Bid per each padot inlet grade adjusted.
- 2. Payment is full compensation for the work described for the item, including all necessary labor, tools, machinery, and materials required to complete the work.

**B. GRADE ADJUSTMENT OF EXISTING PADOT MANHOLE. Each.**

- 1. Payment will be made at the Unit Price Bid per each manhole grade adjusted.
- 2. Payment is full compensation for the work described for the item, including all necessary labor, tools, machinery, and materials required to complete the work.



**ITEM 33 49 13.6071 REBUILD PADOT INLET BOX**

**ITEM 33 49 13.6072 REBUILD PADOT MANHOLE**

**PART I: DESCRIPTION**

- A. 6071 – Rebuild existing inlet box for vertical height greater than 6”.
- B. 6072 – Rebuild existing manhole for vertical height greater than 6”.

**PART II: GENERAL**

- A. When ordered by Director, rebuild inlet box or manhole, in accordance with Director’s instructions as determined in the field and the applicable Sections of City of Pittsburgh Specifications.
- B. The extent of rebuild is to conform to the Director’s orders given in the field.
- C. Rebuild structures as specified in PADOT Publication 408, Section 607 – Rebuilt Miscellaneous Structures. Conform PADOT specifications to applicable sections of City of Pittsburgh Specifications.

**PART III: PRODUCTS AND MATERIALS**

- A. Provide products and materials specified in PADOT 408, Section 607.2 Material or approved type.

**PART IV: CONSTRUCTION AND EXECUTION**

- A. Execute work as specified in PADOT 408, Section 607.3 Construction.

**PART V: MEASUREMENT AND PAYMENT**

**A. REBUILD PADOT INLET BOX. Linear Vertical Foot.**

- 1. Payment will be made at the Unit Price Bid per linear vertical foot of rebuilt PADOT inlet box. Payment will be made to the nearest 0.1 foot, except that heights less than the first foot will be paid for as 1 vertical foot.
- 2. Payment is full compensation for the work described for the item, including all necessary labor, tools, machinery, and materials required to complete the work.

**B. REBUILD PADOT MANHOLE. Linear Vertical Foot.**

- 1. Payment will be made at the Unit Price Bid per linear vertical foot of rebuilt PADOT manhole. Payment will be made to the nearest 0.1 foot, except that heights less than the first foot will be paid for as 1 vertical foot.
- 2. Payment is full compensation for the work described for the item, including all necessary labor, tools, machinery, and materials required to complete the work.

END OF SECTION 33 49 13

[THIS PAGE BLANK]

**SECTION 34 71 13 – VEHICLE BARRIERS**

**ITEM 34 71 13.0052 VEHICLE MEDIAN BARRIERS**

**PART I: DESCRIPTION**

- A. 0052 – PADOT single face cement concrete median barrier.

**PART II: GENERAL**

- A. When ordered by Director, furnish and install vehicle median barriers, in accordance with Director's instructions as determined in the field and the applicable Sections of City of Pittsburgh Specifications.
- B. The extent installation is to conform to Director's orders given in the field.
- C. Vehicle Median Barriers as specified in PADOT Publication 408, Section 623 – Concrete Median Barrier and as shown on Standard Drawing RC 58M – Single Face Concrete Barrier. Conform PADOT specifications to applicable sections of City of Pittsburgh Specifications.

**PART III: PRODUCTS AND MATERIALS**

- A. Provide products and materials specified in PADOT 408, Section 623.2 Material or approved type.
1. Vehicle Median Barrier: PADOT Single Face Concrete Barrier

**PART IV: CONSTRUCTION AND EXECUTION**

- A. Execute work as specified in PADOT 408, Section 623.3 Construction.

**PART V: MEASUREMENT AND PAYMENT**

**A. VEHICLE MEDIAN BARRIERS. Linear Foot.**

1. Payment will be made at the Unit Price Bid per linear foot of single face concrete barrier furnished and installed.
2. Payment is full compensation for the work described for the item, including all necessary labor, tools, machinery, and materials required to complete the work.

**ITEM 34 71 13.0500 RESET VEHICLE GUIDE RAILS**

**ITEM 34 71 13.0503 REMOVE VEHICLE GUIDE RAILS**

**ITEM 34 71 13.1025 VEHICLE GUIDE RAILS**

**ITEM 34 71 13.1029 VEHICLE GUIDE RAILS END TREATMENT**

**PART I: DESCRIPTION**

- A. 0500 – Re-setting of existing guide rail, including all appurtenances and hardware.
- B. 0503 – Removal of existing guide rail, including all appurtenances and hardware.
- C. 1025 – PADOT Guide Rail, Type 2-W.
- D. 1029 – PADOT Guide Rail End Treatment, Type 2-W End Treatment, Driveways and Openings.

**PART II: GENERAL**

- A. When ordered by Director, remove, reset or furnish and install vehicle guide rails, in accordance with Director's instructions as determined in the field and the applicable Sections of City of Pittsburgh Specifications.
- B. The extent of removal or installation is to conform to Director's orders given in the field.
- C. Vehicle guide rails as specified in PADOT Publication 408, Section 620 – Guide Rail and as shown on Standard Drawing RC 53M – Type 2 Weak Post Guide Rail. Conform PADOT specifications to applicable sections of City of Pittsburgh Specifications.

**PART III: PRODUCTS AND MATERIALS**

- A. Provide products and materials specified in PADOT 408, Section 620.2 Material or approved type.
  - 1. Vehicles Guide Rails: PADOT Guide Rail, Type 2-W
  - 2. Vehicles Guide Rails End Treatment: PADOT Type 2-W End Treatment, Driveways and Openings

**PART IV: CONSTRUCTION AND EXECUTION**

- A. Execute work as specified in PADOT 408, Section 620.3 Construction.

**PART V: MEASUREMENT AND PAYMENT**

**A. RESET VEHICLE GUIDE RAILS. Linear Foot.**

- 1. Payment will be made at the Unit Price Bid per linear foot of guide rail re-installed.
- 2. Payment is full compensation for the work described for the item, including all necessary labor, tools, machinery, and materials required to complete the work.

**B. REMOVE VEHICLE GUIDE RAILS. Linear Foot.**

- 1. Payment will be made at the Unit Price Bid per linear foot of guide rail removed.
- 2. Payment is full compensation for the work described for the item, including all necessary labor, tools, machinery, and materials required to complete the work.

**C. VEHICLE GUIDE RAILS. Linear Foot.**

- 1. Payment will be made at the Unit Price Bid per linear foot of guide rail furnished and installed.
- 2. Payment is full compensation for the work described for the item, including all necessary labor, tools, machinery, and materials required to complete the work.

**D. VEHICLE GUIDE RAILS END TREATMENT. Each.**

- 1. Payment will be made at the Unit Price Bid per each guide rail end treatment furnished and installed.

Housing Authority of the City of Pittsburgh  
Authority-wide Site Improvements

2. Payment is full compensation for the work described for the item, including all necessary labor, tools, machinery, and materials required to complete the work.

END OF SECTION 34 71 13

[THIS PAGE BLANK]

**HOUSING AUTHORITY OF THE CITY OF PITTSBURGH**

**Request for Proposals**

**AUTHORITY WIDE SITE IMPROVEMENTS**

**ATTACHMENT N**

**Special Provisions  
Documents Required for Payment**

## **SPECIAL PROVISIONS**

### **Authority Wide Site Improvements**

Documents Required for Payment  
HACP Contract No.: 600-33-19

---

Pursuant to Sections 27, 38, 40 and 46 of the General Conditions for this Contract, each contractor must submit the following required documents with each Payment Estimate (“PE”) in order for HACP to process a PE as follows:

- A. Periodic Estimate – HUD 51001**
- B. Schedule of Stored Materials – HUD 51003** (if applicable)
- C. Summary of Stored Materials – HUD 51004** (if applicable)
- D. Schedule of Change Orders – HUD 51002** (if applicable)
- E. Progress Payment Certification**
- F. Current/Approved Certified Payrolls** (submitted to HACP’s Davis-Bacon Wage Clerk).
- G. MBE/WBE Utilization Report**
- H. Section 3 Summary Report**

Signature of Authorized Officer: \_\_\_\_\_

Date: \_\_\_\_\_

**THIS DOCUMENT MUST BE SIGNED.**



**HOUSING AUTHORITY OF THE CITY OF PITTSBURGH**

**Request for Proposals**

**AUTHORITY WIDE SITE IMPROVEMENTS**

**ATTACHMENT O**

**Non-Collusion Affidavit**

HOUSING AUTHORITY OF THE CITY OF PITTSBURGH

**NON-COLLUSION  
AFFIDAVIT**

State of \_\_\_\_\_

County of \_\_\_\_\_

\_\_\_\_\_, being first duly sworn, deposes and says:  
*(Printed or Typed Name)*

That he/she is  
*(Proprietor, General Partner, President or Vice President)*

of \_\_\_\_\_; and having submitted the foregoing proposal for  
*(Bidder Name)*

Authority Wide Site Improvements  
\_\_\_\_\_  
*(Project Name)*

**600-33-19**  
\_\_\_\_\_  
*(HACP Contract No.)*

and is the party making the foregoing proposal, and that such proposal is genuine and not collusive or sham; that said party has not colluded, conspired, connived or agreed, directly or indirectly, with any person, to put in a sham proposal, or to refrain from making a proposal, and has not in any manner, directly or indirectly, sought by agreement or collusion, or communication or conference, with any person, to fix the prices of affiant or of any person, or to fix any overhead, profit or cost element of said price, or of that of any person, or to secure any advantage against the Housing Authority of the City of Pittsburgh or any person interested in the proposed contract; and that all statements in said proposal are true.

\_\_\_\_\_  
*(Signature and Date)*

Subscribed and sworn to before me

this \_\_\_\_\_ day of \_\_\_\_\_, 20\_\_

-----

My Commission expires \_\_\_\_\_, 20\_\_